

INTERNATIONAL Scientific JOURNAL
ISSN: 2579-2822

AGRISCIENCE AND TECHNOLOGY

ARMENIAN NATIONAL AGRARIAN UNIVERSITY



ԱԳՐՈՒԳԻՏՈՒԹՅՈՒՆ ԵՎ ՏԵԽՆՈԼՈԳԻԱ

ՀԱՅԱՍՏԱՆԻ ԱԶԳԱՅԻՆ ԱԳՐԱՐԱՅԻՆ ՀԱՄԱԼՍԱՐԱՆ

АГРОНАУКА И ТЕХНОЛОГИЯ

НАЦИОНАЛЬНЫЙ АГРАРНЫЙ УНИВЕРСИТЕТ АРМЕНИИ



4/80
2022



ԽՄԲԱԳՐԱԿԱՆ ԽՈՐՀՈՒՐԴ

Նախագահ	Վ.Է. Ուռուտյան
Գլխավոր խմբագիր	Հ.Ս. Ծպնեցյան
Խորհրդի կազմ	Մ.Ս. Ազադ (Հնդկաստան), Ե.Վ. Բելովա (Ռուսաստան), Ի. Բոբոջոնով (Գերմանիա), Ի. Դյուրիչ (Գերմանիա), Կ. Չուկովսկի (Լեհաստան), Ջ. Հանսֆ (Գերմանիա), Վ. Հովհաննիսյան (ԱՄՆ), Կ.Լ. Մանուելյան Ֆուստե (Իտալիա), Ն. Մերենդինո (Իտալիա), Ս. Մինտա (Լեհաստան), Վ.Ի. Նեչաև (Ռուսաստան), Ա. Շանոյան (ԱՄՆ), Ռ. Շլաուդերեր (Գերմանիա), Պ. Պիտտիա (Իտալիա), Ա.Ռ. Սագուես (Իսպանիա), Յ.Վ. Վերտակովա (Ռուսաստան), Ա.Ֆ. Քուեսադա (Իսպանիա) Ա.Յ. Աբովյան, Ս.Ս. Ավետիսյան, Գ.Հ. Գասպարյան, Ս.Հ. Դավեյան, Գ.Ս. Եղիազարյան, Ա.Մ. Եսոյան, Հ.Ս. Զաքոյան, Ա.Կ. Խոջոյան, Գ.Ն. Համբարձումյան, Է.Ս. Դազարյան, Ս.Վ. Մելոյան, Դ.Ա. Պիպոյան, Դ.Ս. Պիպոյան, Գ.Ժ. Սարգսյան, Ա.Ռ. Սիմոնյան, Ա.Զ. Տեր-Գրիգորյան, Լ.Գ. Տեր-Իսահակյան, Պ.Ա. Տոնապետյան, Ա.Չ. Փեփոյան
Պատասխանատու խմբագիր	Գ.Վ. Սևազյան
Խմբագիր-սրբագրիչներ	Ս.Ա. Եղիազարյան, Մ.Ժ. Դազարյան, Ս.Ռ. Պետրոսյան, Ա.Շ. Սուքիասյան, Ն.Ա. Քարիմյան
Համակարգչային ձևավորում	Կ.Ս. Վարդանյան
Վարչական օգնական	Հ.Հ. Սարգսյան

РЕДАКЦИОННАЯ КОЛЛЕГИЯ

Председатель	В.Э. Урутян
Главный редактор	Г.С. Цпнецян
Состав редколлегии	М.С. Азад (Индия), Е.В. Белова (Россия), И. Бободжонов (Германия), Ю.В. Вертакова (Россия), Дж. Ханф (Германия), И. Дюрич (Германия), А.Ф. Куэсада (Испания), Н. Мерендино (Италия), С. Минта (Польша), В.И. Нечаев (Россия), В. Ованнисян (США), П. Питтия (Италия), А.Р. Сагуэс (Испания), К.М. Фусте (Италия), К. Чуковский (Польша), А. Шаноян (США), Р. Шлаудерер (Германия) А.Ю. Абовян, С.С. Аветисян, Г.Р. Амбарцумян, Г.А. Гаспарян, С.А. Давеян, Г.М. Егизарян, А.М. Есоян, Г.С. Закоян, Э.С. Казарян, С.В. Мелоян, А.З. Пепоян, Д.А. Пипоян, Г.Ж. Саркисян, А.Р. Симонян, А.Дж. Тер-Григорян, Л.Г. Тер-Исаакян, П.А. Тонапетян, А.К. Ходжоян
Ответственный редактор	Г.В. Мнацаканян
Редакторы-корректоры	С.А. Егизарян, М.Ж. Казарян, Н.А. Каримян, С.Р. Петросян, А.Ш. Сукиасян
Компьютерный дизайн	К.С. Варданян
Административный ассистент	Յ.Օ. Տարգսյան

EDITORIAL BOARD

Chairman	V.E. Urutyun
Editor-In-Chief	H.S. Tspnetyan
Editorial Committee	M.S. Azad (India), Ye.V. Belova (Russia), I. Bobojonov (Germany), I. Djuric (Germany), J. Hanf (Germany), V. Hovhannisyun (USA), C.L. Manuelian Fusté (Italy), N. Merendino (Italy), S. Minta (Poland), V.I. Nechaev (Russia), P. Pittia (Italy), A.F. Quesada (Spain), A.X. Roig Sagués (Spain), R. Schlauderer (Germany), A. Shanoyan (USA), Yu. Vertakova (Russia), K. Zukowski (Poland) A.Yu. Abovyan, S.S. Avetisyan, S.H. Daveyan, G.H. Gasparyan, E.S. Ghazaryan, G.R. Hambardzumyan, A.K. Khojoyan, S.V. Meloyan, A.Z. Pepoyan, D.A. Pipoyan, G.Zh. Sargsyan, A.R. Simonyan, A.J. Ter-Grigoryan, L.G. Ter-Isahakyan, P.A. Tonapetyan, G.M. Yeghiazaryan, A.M. Yesoyan, H.S. Zaqoyan
Associate Editor	G.V. Mnatsakanyan
Editor-Proofreaders	M.Zh. Ghazaryan, N.A. Karimyan, S.R. Petrosyan, A.Sh. Sukiasyan, S.A. Yeghiazaryan
Computer Design	K.S. Vardanyan
Administrative Assistant	H.H. Sargsyan

International Scientific Journal

ISSN: 2579 - 2822

AGRISCIENCE AND TECHNOLOGY

Armenian National Agrarian University

ԱԳՐՈՎԻՏՈՒԹՅՈՒՆ ԵՎ ՏԵԽՆՈԼՈԳԻԱ

Հայաստանի ազգային ագրարային համալսարան

АГРОНАУКА И ТЕХНОЛОГИЯ

Национальный аграрный университет Армении

4/80 2022

Երևան Yerevan Երևան
2022

CONTENTS

Agricultural Engineering

- A.V. Altunyan,
A.P. Tarverdyan
- Rheological Basics of the Adjusted Theory on the Plant Stems Sliding Cutting 341
- R.M. Balayan,
A.R. Simonyan
- Determination of the Main Parameters Ensuring Braking Efficiency of Two-Axle Vehicles with Different Malfunctions in the Braking System 347
- T.A. Hovhannisyan,
P.S. Efendyan
- Peculiarities of Introducing Geoinformation System in the Monitoring Procedure of Rangelands in the Republic of Armenia 352
- A.R. Simonyan,
R.M. Balayan,
E.G. Karapetyan,
V.A. Shaghoyan
- Diagnostics of Cars' Gas Supply Systems per Tightness Parameters as a Factor of Ensuring Fire Safety 357

Agricultural Economics and Agribusiness

- V.S. Aleksanyan,
G.H. Keshishyan,
S.N. Shirokov,
I.R. Trushkina
- The Analysis of Seasonal Fluctuations and Correlation Between Monthly Average Exchange Rate of Main Currency and Monthly Average Import Prices of the Main Grain in Armenia 361

Agronomy and Agriecology

- T.B. Aloyan
- Evaluation of Morpho-Biological and Phylogenetic Properties of Several Local Populations of Regionalized Beetroot Varieties in Armenia 367
- A.J. Ter-Grigoryan,
A.A. Manvelyan,
M.H. Ghazaryan
- Identification of Species Composition of Harmful Entomofauna in Seed Storehouses of Some Field Crops 375
- G.A. Tovmasyan,
R.N. Nazaryan
- The Influence of Hail Protection Net Application on the Yield Capacity and Quality of Eggplant and Pepper in Conditions of Ararat Valley, RA 379

Veterinary Science and Animal Breeding

- V.V. Grigoryan,
A.R. Hakobyan,
O.V. Shcherbakov,
L.H. Grigoryan
- Ophthalmohelminthiasis in the Water Basins of Armenia 383

N.H. Harutyunyan, A.M. Manvelyan, M.H. Balayan, A.Z. Pepoyan	Bacterial Communities of Bartonella-Positive Fleas in Gut Microbiota of Armenian Populations	388
A.R. Mkrtchyan, V.V. Grigoryan, H.T. Tadevosyan, L.H. Grigoryan	Some Biological Features of Staphylococci Isolated from Milk of Cows with Mastitis	393
M.A. Sargsyan, H.S. Balasanyan, G.R. Tovmasyan	Study on Swine Brucellosis Infection Rate in the Avan Community of Aragatsotn Region	397
J.T. Simonyan	Study of Acute Bee Paralysis Virus in Some Regions of the Republic of Armenia	402
K.A. Sukiasyan, E.A. Nikoghosyan, A.Yu. Abovyan, T.Ye. Yesayan	New Approaches to the Treatment of Canine Pneumonia	407

Food Science and Technology

Sh.A. Bakhshetsyan, E.R. Gevorgyan, M.N. Mikayelyan	Study of the Possibility of Honey Wine Production Using New Active Dry Yeasts and Yeasts Derivatives	411
A.L. Dashtoyan, S.Z. Nazaryan	The Effect of Aspergillus Niger Fungus on the Development of Fungus Defect in Matured Raw Meat	418
A.Kh. Iskandaryan, M.N. Mikaelyan, E.R. Gevorgyan	Investigation of the Possibility of Cider Production in Armenia Using Different Dry Active Yeasts	422
D.A. Pipoyan, V.I. Chirkova, M.R. Beglaryan, S.A. Stepanyan	Assessing Dietary Exposure of Potentially Toxic Elements via Fish Consumption	428



UDC 631.352.022

Rheological Basics of the Adjusted Theory on the Plant Stems Sliding Cutting

A.V. Altunyan, A.P. Tarverdyan

Armenian National Agrarian University

artur_altunyan@mail.ru, arshaluystar@gmail.com

ARTICLE INFO

Keywords:

*plant raw material,
mathematical model,
rheological properties,
slide cutting,
minimum energy consumption*

ABSTRACT

The second article of the series considers the method of theoretical solution to the problem of plants stems sliding cutting with the account for the rheological properties of the material. In the result of solving the differential equation for the behavior of rheological model selected for the stem, the normal and tangential stresses at the contact zone of blade and stem interaction have been determined. The basic stresses have been determined in the result of the stress states analyses. The obtained results enable to identify the optimal geometric and kinematic parameters, in case of which the sliding cutting can be implemented with minimum energy consumption.

Introduction

Rheological properties of the raw materials and products are vital in the harvesting, raw material treatment, processing and selling procedures in the field of agricultural production, particularly in the plant growing and pomicultural sectors. Such an approach has taken root in recent times and is gradually being strengthened both through theoretical and experimental research.

The main prerequisite for increasing the efficiency of agricultural production is the complete mechanization of the above-mentioned processes; besides, the following requirements are usually presented to the machines implementing the technological processes: effective and high-quality implementation of technological processes with minimal energy consumption.

The mentioned issue is possible to solve only in case when the indices characterizing physico-mechanical, rheological and chemical properties of the developed and influenced environment are taken as a background while developing, designing and calculating such kind of machines. This approach was developed at the start of the 20th century (Goryachkin, 1965) and was further improved by a number of researchers (Zheligovskiy, 1941, Reznik, 1975, Tarverdyan, 1996, Osobov and Noreiko, 1984, Rehkugler, 1966). In the current article an attempt is made to carry out force analysis for the plant stems cutting process taking into account the properties of the material being cut upon their rheological modeling.

Based on the approach that real materials exhibit relaxation and creep properties in the cutting process (Reznik, 1975,

Tarverdyan, 1996, Osobov and Noreiko, 1984, Diamante and Umemoto, 2015), we'll try to introduce the blade and stem stress interaction procedure through some model known in rheology. The axiom well-known in rheology can be assumed as a justification, according to which "any real body is endowed with rheological properties expressed in different degrees" (Reiner, 1965). Multiple scientific research works have been accomplished upon the application of the above stated principle (Altunyan, 2009, Diamante and Umemoto, 2015, Kaliyan and Morey, 2009, Faborode and O'Callaghan, 1989, Dowgiallo, 2005).

The need for a more comprehensive study of the plants stem cutting has been justified in another research work (Tarverdyan and Altunyan, 2022) with the aim of identifying the design and calculation of cutting devices for more efficient, energy saving and reliable harvesters and mowers. Numerous research works have confirmed that the most energy-efficient method of cutting plant stems is the oblique sliding cutting (Goryachkin, 1965, Zheligovskiy, 1941, Tarverdyan, 1996). It is noteworthy that the mentioned statement is mainly based on the empirical data, whereas it is obvious that the nature of cutting phenomenon can be fundamentally revealed through theoretical research. An important prerequisite for the study of plants stems cutting is the determination of the main indices of the stems physico-mechanical properties the latter coming forth as an impact environment. This circumstance has been mentioned by a number of field-specific researchers (Reznik, 1975, Tarverdyan, 1996, Rehkugler, 1966, Altunyan, 2009, Faborode and O'Callaghan, 1989, Dowgiallo, 2005).

Long-term studies on the plants stems anatomical and morphological structure, physico-mechanical properties of the material, different ways and principles of their cutting process (Tarverdyan, 1996, Altunyan, 2009, Tarverdyan, 2004, Filin, 1975) give ground to insist that a more precise solution to the problem of cutting the stems as anisotropic composite body with the knife blade, should be sought in the accurate selection of their rheological models. Such an approach makes it possible to investigate the complete indicators of the physico-mechanical states of the body under study, such as stresses, deformations, changing speeds of stresses and deformations and other manifestations (Filin, 1975, Tarverdyan, 2004, Tarverdyan, 2014).

The aim of the current research work is to study the stress-strain state of the plant stems cutting process representing the properties of the developed environment via rheological modeling.

In this respect, the study of the problem concerning the sliding cutting via blade and enhancing the specified

solution thereto is quite justified both from theoretical and practical perspectives.

Materials and methods

In the result of long-term studies of anatomical and morphological structure of the spiked cereal stems and the physico-mechanical properties of their tissues (Tarverdyan, 1996), it has been grounded that, with some approximation, an assumption can be made that the rheological model of the stem is a model of elasto-plastic adhesive dense medium, which is known as "Bingham body" (Figure 1).

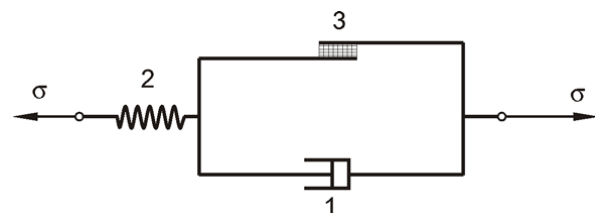

Figure 1. Diagram of the plant stem rheological (elastoplastic adhesive) model (composed by the authors).

It is a combination of Hooke's solid body (2), Newtonian fluid (1) and Saint-Venant or Prandtl body (3) as a mechanical model of rheological body with more complicated properties.

The rheological behavior of the selected body is described through the following equations [8]:

$$\sigma = \varepsilon \cdot E, \text{ where } \sigma \leq \sigma_h$$

$$\sigma = \sigma_h + \eta \left(\frac{d\varepsilon}{dt} - \frac{1}{E} \cdot \frac{\partial \sigma}{\partial t} \right), \text{ where } \sigma > \sigma_h, \quad (1)$$

where σ is the actual total stress in the body being cut (stem), ε is the relative deformation of the material, E is the elasticity modulus of the material, σ_h is the yield point of the material in case of one-dimensional deformation, η is the coefficient of comparability, which depends on the deformation speed, in physical terms it is viscosity coefficient with $\left[\frac{N \cdot s}{m^2} \right]$ measurement.

In the case when the relative deformation increases uniformly $\frac{d\varepsilon}{dt}$ is the speed of the relative deformation (V).

It is known that:

$$\varepsilon = \frac{\Delta \ell}{\ell}, \quad \frac{d\varepsilon}{dt} = \frac{1}{\ell} \cdot \frac{d\Delta \ell}{dt}, \quad (2)$$

where ℓ is the thickness of the cut material (stem diameter), $\Delta\ell$ is the absolute deformation of the material or the blade's path crossed throughout the material.

If it is assumed, that the change of the absolute deformation value, which takes place during a very short time, is uniform, then in the (2) equation we can assign:

$$\frac{d(\Delta\ell)}{dt} = V,$$

hence

$$\frac{d\varepsilon}{dt} = \frac{V}{l}, \tag{3}$$

where V is the absolute deformation speed of the material. On the other hand, V is the equivalent speed, which occurs when implementing cross/direct cutting or cutting without sliding, therefore: $V=V_b$.

By inserting (3) into (1) and conducting some modifications, we get the following:

$$\sigma E + \eta \frac{\partial \sigma}{\partial t} = E\sigma_h + \eta E \frac{V}{l}. \tag{4}$$

In the abovementioned equation V is the absolute deformation speed of the material being cut, which in case of direct cutting, according to the direction, coincides with the vectors of stresses, blade cutting force and cutting speed (absolute cutting) coefficients, anyhow, in case of sliding cutting the vector of cutting speed coefficient deviates from the normal by the slip angle (Figure 2).

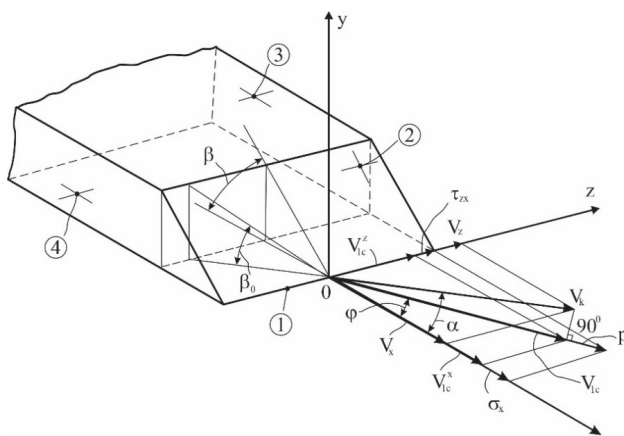

Figure 2. The diagram of stresses identification in the zone of knife blade (1) and stem interaction in case of sliding cutting (composed by the authors).

Results and discussions

The blade cutting resistance of the plant-based solid body has been determined per the (4) equation, considering the force interaction of the cut body with the cutting blade edge (I), facet (II) (by the example of unifacial blade) and the blade spine (III and IV) (Figure 2). Considering that in case of sliding cutting, there is slip angle and that the directions of stress and velocity coefficients don't coincide, the relation of the absolute deformation speed vector with the cutting speed looks as follows:

$$V=V_c=V_r \cdot \cos(\tau-\varphi), \text{ (}\varphi \text{ is the friction angle).}$$

The general form of the solution of the obtained first order linear differential equation (4) is as follows:

$$p = \sigma_h + \eta \frac{V}{\ell} + C \cdot e^{-\frac{Et}{\eta}}, \tag{5}$$

where the coefficient of stress arising in the cutting process is denoted by p instead of σ given that in further judgements the normal stress component will be denoted by σ .

The expression (5) serves as a background to identify the stresses in the mentioned descriptive blade section (Figure 2).

For the blade edge (section I) the base data (initial condition) are as follows:

when $t=0$, $p_t = \sigma_h$, hence: $p_t = \sigma_h + \eta \frac{V}{\ell} + C$ wherefrom by inserting the value of C of $C = -\eta \frac{V}{\ell}$ in (5), we'll have the following:

$$p_t = \sigma_h + \eta \frac{V}{\ell} \left(1 - e^{-\frac{Et}{\eta}} \right), \tag{6}$$

where σ_h is the yield point of the material, thus, it is constant during the cutting deformation, whereas the second summable of the expression is the dynamic stress component.

As mentioned in the above discussed problem it can be assumed that the direction of total stress vector (p) coincides with the vector of deformation or cutting speed (V_c), hence, it is also deviated from the vector of blade shift speed coefficient (V_b) upon the angle of $(\alpha-\varphi)$ (Figure 2).

The normal stress value for the blade edge (I) will be:

$$\sigma_x = p_t \cdot \cos \varphi = \left[\sigma_h + \eta \frac{V_{cx}}{\ell_1} \left(1 - e^{-\frac{Et}{\eta}} \right) \right] \cdot \cos \varphi. \tag{7}$$

Frictional stress along the blade edge will be:

$$\tau_{zx} = p_l \cdot \sin \varphi = \left[\sigma_h + \eta \frac{V_{cz}}{\ell_1} \left(1 - e^{-\frac{Et}{\eta}} \right) \right] \cdot \sin \varphi. \quad (8)$$

As mentioned above the total stress (p) in the discussed situation has the same direction with the cutting speed vector (V_c), which is deviated from the direction of blade shift or external impact force upon ($\alpha-\varphi$) angle. It follows herefrom that the transitional link from the total stress to the external cutting force (P) looks as follows:

$$P = \frac{p \cdot A}{\cos(\alpha-\varphi)} \quad \text{or} \quad (9)$$

$$P = A \cdot \left[\sigma_h + \eta \frac{V}{\ell} \left(1 - e^{-\frac{Et}{\eta}} \right) \right] \cdot \frac{1}{\cos(\alpha-\varphi)},$$

where A is the contact surface of the blade edge and the material being cut.

To determine the interaction force factors emerged on the blade facet (II), let's select rectangular coordinate system $OXYZ$, Z and X axes of which are coincident with the facet plane (XOZ plane coincides with the facet plane), while Y axis is perpendicular to the plane facet (Figure 3).

In other words, the $OXYZ$ system depicted in Figure 2 has rotated round the Z axis upon angle (in Figure 3 the mentioned system is O).

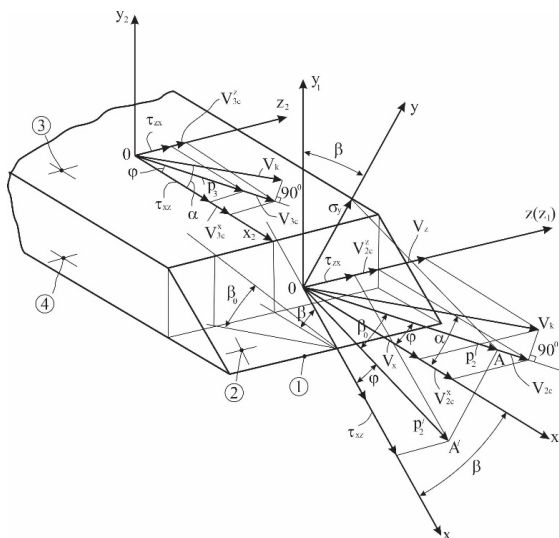

Figure 3. The diagram of contact stresses identification at the interaction plane of blade facet and blade spine with the stem in case of sliding cutting (composed by the authors).

The vectors of blade speed (V_b), cutting speed (V_c) and total stress are situated in the same X_1OZ horizontal plane (Figure 3).

If projecting p_2 vector of total stress towards the directions of X , Y and Z , we'll get:

$$\begin{cases} \sigma_y = \overline{AA'} = p_2 \sin \beta_0; & (\sigma_x = \sigma = 0), \\ \tau_{xy} = \overline{OA'} \cos \varphi = p_2 \cos \beta_0 \cdot \cos \varphi, \\ \tau_{yx} = \overline{OA'} \sin \varphi = p_2 \cos \beta_0 \cdot \sin \varphi, \end{cases} \quad (10)$$

where β_0 is the facet gradient, transformation angle of β angle, it is determined through the following expression: $\beta_0 = \arctg(\tg \beta \cdot \cos \alpha)$; p_2 is the total stress of the blade facet and the material being cut and it is determined through the same expressions as in case of p_l :

$$p_2 = \sigma_h + \eta \frac{V_2}{\ell_2} + C_2 \cdot e^{-\frac{Et_2}{\eta}}. \quad (11)$$

Upon the initial condition C_2 constant is determined: if $t_2=0 : p_2=p_l$, then:

$$\sigma_h + \frac{\eta V_1}{\ell_1} \left(1 - e^{-\frac{Et_1}{\eta}} \right) = \sigma_h + \eta \frac{V_2}{\ell_2} + C_2, \quad \text{where from,}$$

when placing $C_2 = \frac{\eta V_1}{\ell_1} \left(1 - e^{-\frac{Et_1}{\eta}} \right) - \frac{\eta V_2}{\ell_2}$ in (11), we'll get:

$$p_2 = \sigma_h + \frac{\eta V_2}{\ell_2} + \left[\frac{\eta V_1}{\ell_1} \left(1 - e^{-\frac{Et_1}{\eta}} \right) - \frac{\eta V_2}{\ell_2} \right] \cdot e^{-\frac{Et_2}{\eta}}. \quad (12)$$

On the blade facet for the normal and frictional stress we'll have:

$$\begin{cases} \sigma_y = \left\{ \sigma_h + \frac{\eta V_{2y}}{\ell_2} + \left[\frac{\eta V_{1y}}{\ell_1} \left(1 - e^{-\frac{Et_1}{\eta}} \right) - \frac{\eta V_{2y}}{\ell_2} \right] \cdot e^{-\frac{Et_2}{\eta}} \right\} \sin \beta_0, \\ \tau_{xz} = \left\{ \sigma_h + \frac{\eta V_2}{\ell_2} + \left[\frac{\eta V_{2x}}{\ell_1} \left(1 - e^{-\frac{Et_1}{\eta}} \right) - \frac{\eta V_{2x}}{\ell_2} \right] \cdot e^{-\frac{Et_2}{\eta}} \right\} \cos \beta_0 \cdot \cos \varphi, \\ \tau_{zx} = \left\{ \sigma_h + \frac{\eta V_2}{\ell_2} + \left[\frac{\eta V_{1z}}{\ell_1} \left(1 - e^{-\frac{Et_1}{\eta}} \right) - \frac{\eta V_{2z}}{\ell_2} \right] \cdot e^{-\frac{Et_2}{\eta}} \right\} \cos \beta_0 \cdot \sin \varphi. \end{cases} \quad (13)$$

In the upper and lower planes of the blade spine (III and IV zones) the mechanical picture of interaction with the body being cut is identical. In Figure 3 the diagram of speeds, total stresses and their components is designed only for the upper plane.

For the plane, the solution of differential equation looks as follows:

$$p_3 = \sigma_h + \eta \frac{V_3}{\ell_3} + C_3 \cdot e^{-\frac{Et_3}{\eta}} \quad (14)$$

The constant of C_3 integration is determined from the following initial condition:

when $t_3=0, p_3=p_2$, wherefrom it follows:

$$C_3 = \frac{\eta V_2}{\ell_2} + \left[\frac{\eta V_1}{\ell_1} \left(1 - e^{-\frac{Et_1}{\eta}} \right) - \frac{\eta V_2}{\ell_2} \right] \cdot e^{-\frac{Et_2}{\eta}} - \frac{\eta V_3}{\ell_3}$$

When placing the value of C_3 in (14), we'll get:

$$p_3 = \sigma_h + \eta \frac{V_3}{\ell_3} + \left\{ \frac{\eta V_2}{\ell_2} + \left[\frac{\eta V_1}{\ell_1} \left(1 - e^{-\frac{Et_1}{\eta}} \right) - \frac{\eta V_2}{\ell_2} \right] \cdot e^{-\frac{Et_2}{\eta}} - \frac{\eta V_3}{\ell_3} \right\} \cdot e^{-\frac{Et_3}{\eta}} \quad (15)$$

The frictional stresses in the blade spine planes are determined in the following way:

$$\begin{aligned} \tau_{xz} &= p_3 \cdot \cos \varphi, \\ \tau_{zx} &= p_3 \cdot \sin \varphi. \end{aligned} \quad (16)$$

When determining the cutting resistance forces via stresses in the blade planes (III and IV), the results obtained from (12) expressions should be doubled, so as to consider the impact of both planes.

When determining stresses caused throughout the cutting process by the (7), (8), (11) and (12) expressions, the speed components in the specific blade zone are marked, and since the blade speed (V_b) is known in each specific problem, the components are also known:

$$\begin{aligned} V_{1x}^c &= V_{3x}^c = V_c \cos \varphi, & V_{1z}^c &= V_{3z}^c = V_c \sin \varphi, \\ V_{1c} &= V_{3c} = V_b \cos(\alpha - \varphi), & V_{2y}^c &= V_{2c} \sin \beta, \\ V_{2x}^c &= V_{2c} \cos \beta \cdot \cos \varphi, & V_{2z}^c &= V_{2c} \cos \beta \cdot \sin \varphi, \\ V_{2c} &= V_b \cos(\alpha - \varphi) \cdot \cos \beta_0. \end{aligned}$$

In the stress determination expressions the main variable is the cutting time, since the cutting depth is also a function dependent on time $\ell = f(t)$, hence when making practical calculations with the derived theoretical expressions, it is necessary to denote time with seconds in $0 \leq t \leq t_4$ interval, where t_4 is the time required for the complete stem cutting.

As it was already mentioned in the previous series of the article (Tarverdyan and Altunyan, 2022), where the cutting process was viewed as a forced crack propagation, as a result of theoretical research, expressions were derived

which enable to identify the basic stresses in the already known zones of the blade. To compare the recommended two approaches, let's leave the base data unchanged. The material to be cut is the stem of "Bezostaya-1" wheat variety in its full maturity period, the stem diameter is $d=4 \cdot 10^{-3}$ m, the yield point (flow point) of the stem matter $\sigma_y=270$ MPa, elasticity modulus - $E=6 \cdot 10^4$ MPa, strength limit - $\sigma_h=320$ MPa, frictional coefficient - $tg\alpha=0.31$, the acute angle of the blade facet - $\beta=18^0$ blade speed - $V_b=20$ m/s, $\eta=4 \cdot 10^3$ MP*s; $\alpha=68^0$; $0 \leq t \leq t_c$ (t_c) is the stem cutting duration $t_c = 2 \cdot 10^{-4}$ s. By placing the base data in the (7), (8), (13), (15) and (16) expressions, the force factors of blade and cutting stem interaction are determined in the form of normal and frictional stresses in the mentioned descriptive blade zones.

In this option of problem solution, the following numerical values for the basic stresses caused in the material being cut at the descriptive blade zones/sections have been derived:

$$\begin{aligned} \sigma_{1(i)} &= 387.0 \text{ MPa}, & \sigma_{1(ii)} &= 288.0 \text{ MPa}, \\ \sigma_{1(iii)} &= \sigma_{1(iv)} = 256.0 \text{ MPa}. \end{aligned}$$

In the previous options of the problem solution, the following numerical values were obtained for the same units:

$$\begin{aligned} \sigma^*_{1(i)} &= 430.0 \text{ MPa}, & \sigma^*_{1(ii)} &= 315 \text{ MPa}, \\ \sigma^*_{1(iii)} &= \sigma^*_{1(iv)} = 275.0 \text{ MPa}. \end{aligned}$$

Comparing the results of the two options it can be concluded, that though the results differ by about 10 %, their changing regularity is almost the same, so

$$\begin{aligned} \sigma^*_{1(i)} : \sigma^*_{1(ii)} &= 1.365, & \sigma_{1(i)} : \sigma_{1(ii)} &= 1.344, \\ \sigma^*_{1(iii)} : \sigma^*_{1(iv)} &= 1.145, & \sigma_{1(iii)} : \sigma_{1(iv)} &= 1.125, \\ \sigma_{1(i)} : \sigma_{1(iii)} &= 1.563 & \sigma_{1(ii)} : \sigma_{1(iv)} &= 1.512. \end{aligned}$$

It follows wherefrom that both solution methods correctly address the mechanics of cutting process. Whereas, which of the methods is more precise will become clear in the result of experimental research.

Conclusion

1. The normal and frictional stresses in the cutting zone of the material, on the planes of blade edge, facet and on both planes of the blade spine in case of sliding cutting have been determined through the integration of differential equation describing rheological behavior of the selected model for the stem of spiked cereal crops.
2. The normal and frictional stresses identified in the interaction zone of blade and cutting material have been viewed as force factors for the cutting material and in the

result of stress state analysis in the relevant zones/sectors, the basic stresses have been identified and the conditions under which the material is decomposed upon the effect of possibly minimum external factors have been set up.

3. Collating the two options of problem solution related to the stem sliding cutting (in the first option considering cutting as a forced crack propagation and in the second one – as a dynamic process in view of rheological properties of the material), it can be stated that though there is about 10 % incompatibility between the results of the mentioned methods, their changing patterns in the sectors of blade edge and spine planes are identical.

References

1. Altunyan, A.V. (2009). Developing a Technology of Stem Cutting in Dense Medium / Thesis of Candidate (PhD) of Technical Sciences. Yerevan (in Armenian).
2. Diamante, L., Umemoto, M. (2015). Rheological Properties of Fruits and Vegetables: A Review. *International Journal of Food Properties*, 18(6), - pp. 1191-1210.
3. Dowgiallo, A. (2005). Cutting Force of Fibrous Materials. *Journal of Food Engineering*. 66(1), - pp. 57-61. <https://doi.org/10.1016/j.jfoodeng.2004.02.034>.
4. Faborode, M.O., O'Callaghan, J.R. (1989). A Rheological Model for the Compaction of Fibrous Agricultural Materials. *Journal of Agricultural Engineering Research*, - 42(3), - pp. 165-178.
5. Filin, A.P. (1975). *Applied Mechanics of a Solid Deformable Body in 3 Volumes*, Nauka Publishing House, Moscow (in Russian).
6. Goryachkin, V.P. (1965). *Collected Works in Three Volumes*, Moscow, Kolos (in Russian).
7. Kaliyan, N., Morey, R.V. (2009). Constitutive Model for Densification of Corn Stover and Switchgrass. *Biosystems Engineering*, 104(1), - pp. 47-63. <https://doi.org/10.1016/j.biosystemseng.2009.05.006>.
8. Osobov, V.I., Noreiko, V.G. (1984). Pressing Coarse Feeds. *Agricultural Mechanization and Electrification*, 10, - pp. 50-51 (in Russian).
9. Rehgugler, G. E. (1966). *The Biomechanics of Forage Wafering*. Iowa State University of Science and Technology. Ames, Iowa.
10. Reiner, M. (1965). *Rheology*. /Translated from English / Moscow: Nauka, - 224 p. (in Russian).
11. Reznik, N.E. (1975). *The Theory of Cutting with a Blade and the Basics of Calculating Cutting Devices*. Moscow, Mechanical Engineering (in Russian).
12. Tarverdyan, A.P. (2014). *Application of the Vibration Theory in Agricultural Mechanics*. Yerevan, Gitutyun.
13. Tarverdyan, A.P. (1996). *Technical and Technological Bases for the Creation of Cutting Devices for Harvesters and Mowers*. PhD Thesis, Yerevan (in Russian).
14. Tarverdyan, A.P. (2004). *Essential Principles for Development of Rotary Cutting Devices*. Verlag Grauer, Beuren, Stuttgart.
15. Tarverdyan, A.P., Altunyan, A.V. (2022). Theoretical Justification of the Dynamic Parameters in Plant Stems Sliding Cutting // *Agriscience and Technology*, - 2(78) - pp. 123-129.
16. Zheligovskiy, V.A. (1941). *Experimental Theory of Blade Cutting*. Proceedings of Moscow State Agricultural Institute of Mechanization and Electrification, Edition IX, Moscow (in Russian).

*Accepted on 10.10.2022
Reviewed on 01.11.2022*



UDC 629.3.02-59

Determination of the Main Parameters Ensuring Braking Efficiency of Two-Axle Vehicles with Different Malfunctions in the Braking System

R.M. Balayan, A.R. Simonyan

Armenian National Agrarian University

expert.balayan18@gmail.com, arman.simonyan@anau.am

ARTICLE INFO

Keywords:

speed,
braking,
deceleration,
stopping distance,
adhesion coefficient,
parameter

ABSTRACT

The aim of the current work is to find out the effect of malfunction in the working brake system on the main parameters of the braking process and its performance, and hence, on the accuracy of the expert's conclusion, proposing relevant principles that should guide the experimental research.

The analysis of expert practice in car technical inspection testifies that the majority of questions addressed to the experts are related to the vehicle brake system and its efficiency assessment.

Introduction

The studies of multiple researchers (Balayan, et al., 2008, Bekasov, et al., 1967, Evtjukov and Vasiliev, 2006, Krinitsyn, 1987, Guidelines for Experts, Puchkin, 2010, Suvorov, 2004, Auto-Technical Forensic Examination, 1980) on braking efficiency/performance show that the stopping and braking distances, as well as braking time and movement speed per braking track are determined through the value of maximum deceleration, which the vehicle achieves via emergency braking.

Braking is one of the main quantities for an expert to determine the mechanism of an accident and resolve the issue of the technical feasibility of preventing an accident by braking the vehicle, as well as to create its mathematical model, to analyze various interpretations by the investigator and the court. The amount of deceleration

depends on many objective factors, including the road and weather conditions at the time of the accident, the structural features of the vehicle and its technical condition.

The amount of deceleration of a specific vehicle (J , m/s^2) is determined by conducting an investigative experiment in the road conditions of the accident site. If the latter is not possible it can be determined according to informational data, according to the norms established by GOST R 51709-2001 Road traffic rules, or by calculation method.

According to expert practice, the determination of vehicles deceleration amount through calculation method is conducted with the formulae developed by V.A. Bekasov and N.M. Christie (Bekasov, et al., Krinitsyn, 1987). Formulae for determining the amount of deceleration of two-axle vehicles with a faulty brake system are given in the form of a table (Bazikyan and Balayan, 2003, Balayan,

et al., Evtuykov and Vasiliev, 2006, Auto-Technical Forensic Examination, 1980).

Materials and methods

Upon the conducted brief overview it becomes clear that in the expert practice, especially when determining the brake parameters of a vehicle with a faulty brake system, it is necessary to take into account a number of principles that can have a significant impact on the results, not excluding possible errors in the expert’s conclusion. The foregoing can be shown in detail with examples, using both the technical device and the values of deceleration, braking and stopping distance of a car with faulty brake systems.

Results and discussions

Let’s take the passenger car VAZ 2109, M1 category,

empty and fully loaded, as the study object. The road surface is asphalt-concrete, dry, flat with horizontal site. The car speed is $V_c=40$ km/h (11 m/s). The driver’s reaction time is $t_r=0.8$ s.

The technical parameters are as follows: t_2 and t_3 , coefficient of longitudinal adhesion between tire and road surface is φ according to guidelines for experts.

The car base is $L=2.460$ m, coordinates of gravity center are as follows: without load – $a=0.580$ m; $h_{g.c.}=0.560$ m, fully loaded – $a=1.260$ m; $h_{g.c.}=1.050$ m (Suvorov, 2004).

The amount of deceleration during the movement of a VAZ-2109 car braked on a flat horizontal road, with the wheels locked, is determined by the following formula:

$$J = g \cdot \varphi = 9.81 \cdot (0.7 \div 0.8) \approx (6.8 \div 7.8) \text{ m/s}^2. \quad (1)$$

Table. Analytical calculation of deceleration, braking distance and stopping distance of a two-axle vehicle (VAZ-2109 without load/with load) with a working brake system with different types of malfunctions*

Type of malfunction of the working brake system in a two-axle vehicle	Deceleration calculation formula	Calculated value of J, m/s ²	Braking distance formula	Calculated value of S _b , m	Stopping distance formula	Calculated value of S _s , m
$b = L - a = \frac{2.46 - 0.58}{2.46 - 1.26} = \frac{1.88m}{1.2m}, \varphi_a = \frac{0.7 \div 0.8}{1.2} = 0.58 \div 0.67, t_1 = 0.8 \text{ s}, t_2 = 0.1 \text{ s}, t_3 = 0.35 \text{ s}$						
Braking system of the technical device	$J = g \cdot \frac{\varphi}{k_e}$	5.7÷6.5	$S_b = (t_2 + 0.5t_3) \cdot V_b + V_b^2/2J$	13.9÷12.5	$S_s = (t_1 + t_2 + 0.5t_3) \cdot V_b + V_b^2/2J$	22.5÷21.1
A front wheel fails to brake	$J = \frac{(L+a) \cdot \varphi_a \cdot g}{2L + h_{g.c.} \cdot \varphi_a}$	$\frac{3.3 \div 3.8}{3.8 \div 4.3}$		$\frac{21.8 \div 19.3}{19.3 \div 17.4}$		$\frac{30.4 \div 27.9}{27.9 \div 26.0}$
A rear wheel fails to brake	$J = \frac{(L+b) \cdot \varphi_a \cdot g}{2L - h_{g.c.} \cdot \varphi_a}$	$\frac{5.4 \div 6.3}{4.8 \div 5.7}$		$\frac{14.5 \div 12.8}{15.9 \div 13.9}$		$\frac{23.1 \div 21.5}{24.5 \div 22.5}$
A front wheel brakes	$J = \frac{b \cdot \varphi_a \cdot g}{2L - h_{g.c.} \cdot \varphi_a}$	$\frac{2.3 \div 2.7}{1.6 \div 1.9}$		$\frac{29.9 \div 25.9}{41.6 \div 35.5}$		$\frac{38.5 \div 34.5}{50.2 \div 44.1}$
A rear wheel brakes	$J = \frac{a \cdot \varphi_a \cdot g}{2L + h_{g.c.} \cdot \varphi_a}$	$\frac{0.6 \div 0.7}{1.3 \div 1.5}$		$\frac{105.9 \div 91.2}{50.5 \div 44.2}$		$\frac{114.5 \div 99.8}{59.1 \div 52.8}$
Only front wheels brake	$J = \frac{b \cdot \varphi_a \cdot g}{L - h_{g.c.} \cdot \varphi_a}$	$\frac{5 \div 5.9}{3.7 \div 4.5}$		$\frac{15.4 \div 13.5}{19.7 \div 16.8}$		$\frac{24.0 \div 22.1}{28.3 \div 25.4}$
Only rear wheels brake	$J = \frac{a \cdot \varphi_a \cdot g}{L + h_{g.c.} \cdot \varphi_a}$	$\frac{1.2 \div 1.3}{2.3 \div 2.6}$		$\frac{54.5 \div 50.5}{29.9 \div 26.8}$		$\frac{63.1 \div 59.1}{38.5 \div 35.4}$
The wheels of only one side brake	$J = g \cdot \frac{\varphi_a}{2}$	2.8÷3.3		25.1÷21.7		33.73÷30.4

Continuation of the table*

1	2	3	4	5	6	7
$\varphi_a = \frac{0.5 \div 0.6}{1.1} = 0.45 \div 0.54, \varphi_a = \frac{0.5 \div 0.6}{1.2} = 0.42 \div 0.5, t_2 = 0.1 \text{ s}, t_{31} = 0.3 \text{ s}, t_{32} = 0.25 \text{ s}$						
Braking system of the technical device	$J = g \cdot \frac{\varphi}{k_e}$	$\frac{4.4 \div 5.3}{4.1 \div 4.9}$	$S_b = (t_2 + 0.5t_3) \cdot V_b + V_b^2/2J$	$\frac{16.8 \div 14.4}{17.5 \div 15.4}$ $\frac{16.5 \div 14.4}{17.5 \div 15.1}$	$S_s = (t_1 + t_2 + 0.5t_3) \cdot V_b + V_b^2/2J$	$\frac{25.7 \div 23.3}{26.4 \div 24.3}$ $\frac{25.4 \div 23.3}{26.4 \div 24.0}$
A front wheel fails to brake	$J = \frac{(L+a) \cdot \varphi_a \cdot g}{2L + h_{g.c.} \cdot \varphi_a}$	$\frac{2.6 \div 3.1}{2.8 \div 3.3}$		$\frac{26.5 \div 22.7}{24.8 \div 21.5}$ $\frac{26.2 \div 22.4}{24.5 \div 21.2}$		$\frac{35.4 \div 31.6}{33.7 \div 30.4}$ $\frac{35.1 \div 31.3}{33.4 \div 30.1}$
A rear wheel fails to brake	$J = \frac{(L+b) \cdot \varphi_a \cdot g}{2L - h_{g.c.} \cdot \varphi_a}$	$\frac{4.1 \div 5.0}{3.4 \div 4.1}$		$\frac{17.8 \div 15.1}{20.9 \div 17.8}$ $\frac{17.5 \div 14.8}{20.6 \div 17.5}$		$\frac{26.7 \div 24.0}{29.8 \div 26.7}$ $\frac{26.4 \div 23.7}{29.5 \div 26.4}$
A front wheel brakes	$J = \frac{b \cdot \varphi_a \cdot g}{2L - h_{g.c.} \cdot \varphi_a}$	$\frac{1.8 \div 2.1}{1.1 \div 1.3}$		$\frac{37.1 \div 32.2}{58.9 \div 50.2}$ $\frac{36.8 \div 31.9}{58.6 \div 49.9}$		$\frac{46.0 \div 41.1}{67.8 \div 59.1}$ $\frac{45.7 \div 40.8}{67.5 \div 58.8}$
A rear wheel brakes	$J = \frac{a \cdot \varphi_a \cdot g}{2L + h_{g.c.} \cdot \varphi_a}$	$\frac{0.5 \div 0.6}{1.0 \div 1.1}$		$\frac{126.2 \div 105.6}{64.5 \div 58.9}$ $\frac{125.9 \div 105.3}{64.2 \div 58.6}$		$\frac{135.1 \div 114.5}{73.4 \div 67.8}$ $\frac{134.8 \div 114.2}{73.1 \div 67.5}$
Only front wheels brake	$J = \frac{b \cdot \varphi_a \cdot g}{L - h_{g.c.} \cdot \varphi_a}$	$\frac{3.8 \div 4.6}{2.4 \div 3.0}$		$\frac{19.0 \div 16.2}{28.9 \div 23.3}$ $\frac{18.7 \div 15.9}{28.2 \div 23.0}$		$\frac{27.9 \div 25.1}{37.4 \div 32.2}$ $\frac{27.6 \div 24.8}{37.1 \div 31.9}$
Only rear wheels brake	$J = \frac{a \cdot \varphi_a \cdot g}{L + h_{g.c.} \cdot \varphi_a}$	$\frac{0.9 \div 1.1}{1.8 \div 2.1}$		$\frac{71.3 \div 58.9}{37.1 \div 32.2}$ $\frac{71.0 \div 58.6}{36.8 \div 31.9}$		$\frac{80.0 \div 67.8}{46.0 \div 41.1}$ $\frac{79.9 \div 67.5}{45.7 \div 40.8}$
The wheels of only one side brake	$J = g \cdot \frac{\varphi_a}{2}$	$\frac{2.2 \div 2.6}{2.1 \div 2.4}$		$\frac{30.8 \div 26.5}{32.2 \div 28.5}$ $\frac{30.5 \div 26.2}{58.6 \div 28.2}$		$\frac{39.7 \div 35.4}{41.1 \div 37.4}$ $\frac{39.4 \div 35.1}{67.5 \div 37.1}$
$\varphi_a = \frac{0.3 \div 0.4}{1.0} = 0.3 \div 0.4, t_2 = 0.1 \text{ s}, t_{31} = 0.2 \text{ s}, t_{32} = 0.15 \text{ s}$						
Braking system of the technical device	$J = g \cdot \frac{\varphi}{k_e}$	$2.9 \div 3.9$	$S_b = (t_2 + 0.5t_3) \cdot V_b + V_b^2/2J$	$23.2 \div 18.0$	$S_s = (t_1 + t_2 + 0.5t_3) \cdot V_b + V_b^2/2J$	$32.1 \div 26.9$
A front wheel fails to brake	$J = \frac{(L+a) \cdot \varphi_a \cdot g}{2L + h_{g.c.} \cdot \varphi_a}$	$\frac{1.7 \div 2.3}{2.1 \div 2.7}$		$\frac{38.2 \div 29.0}{31.3 \div 25.1}$		$\frac{47.1 \div 37.9}{40.2 \div 34.0}$
A rear wheel fails to brake	$J = \frac{(L+b) \cdot \varphi_a \cdot g}{2L - h_{g.c.} \cdot \varphi_a}$	$\frac{2.7 \div 3.5}{2.3 \div 3.2}$		$\frac{24.8 \div 19.8}{28.8 \div 21.5}$		$\frac{32.9 \div 27.9}{37.7 \div 30.4}$
A front wheel brakes	$J = \frac{b \cdot \varphi_a \cdot g}{2L - h_{g.c.} \cdot \varphi_a}$	$\frac{1.1 \div 1.6}{0.8 \div 1.0}$		$\frac{58.0 \div 40.8}{125.4 \div 63.9}$		$\frac{66.9 \div 49.7}{134.3 \div 72.8}$
A rear wheel brakes	$J = \frac{a \cdot \varphi_a \cdot g}{2L + h_{g.c.} \cdot \varphi_a}$	$\frac{0.3 \div 0.4}{0.7 \div 0.8}$		$\frac{207.6 \div 156.5}{90.1 \div 79.4}$		$\frac{216.5 \div 165.4}{99.0 \div 88.3}$
Only front wheels brake	$J = \frac{b \cdot \varphi_a \cdot g}{L - h_{g.c.} \cdot \varphi_a}$	$\frac{2.5 \div 3.3}{1.6 \div 2.3}$		$\frac{26.6 \div 20.9}{40.5 \div 29.0}$		$\frac{35.5 \div 29.8}{49.4 \div 37.9}$
Only rear wheels brake	$J = \frac{a \cdot \varphi_a \cdot g}{L + h_{g.c.} \cdot \varphi_a}$	$\frac{0.6 \div 0.8}{1.3 \div 1.7}$		$\frac{104.8 \div 79.4}{49.4 \div 38.5}$		$\frac{113.7 \div 88.3}{58.3 \div 47.4}$
The wheels of only one side brake	$J = g \cdot \frac{\varphi_a}{2}$	$1.5 \div 2.0$		$43.1 \div 33.1$		$52.0 \div 42.0$

*Composed by the authors.

According to Evtuykov and Vasiliev $J = \varphi_a \cdot g$, (2) or according to Technical Forensic Expertise $J = g \cdot \frac{\varphi}{k_e}$ m/s² (3), where φ_a is the adhesion coefficient, which upon the joint solution of (2 and 3) formulae will be equal to:

$$\varphi_a = \frac{\varphi}{k_e}, \quad (4)$$

$g=9.81$ m/s² is the acceleration of free fall, k_e is the coefficient of braking efficiency, accounting for the degree of use of the adhesion sum force of the tires of the braked wheels with the surface of the passing part, which according to technical expertise is assumed to be as follows: in case of $\varphi \geq 1.7$ $k_e=1.2$, in case of $\varphi = 0.5 \div 0.6$ $k_e=1.1$, and in case of $\varphi \leq 0.4$ $k_e=1.0$.

As it can be seen from the calculations, the main parameters of the brake system performance, and, therefore, the accuracy of the expert's conclusion, are significantly affected by the following malfunctions of the brake system, respectively: only rear wheels brake, a front wheel brakes, the wheels of only one side brake, a front wheel fails to brake, only the front wheels brake and a rear wheel fails to break. For example, among the mentioned malfunctions, the most significant effect on the parameters is exerted, when a rear wheel brakes. In this case the deceleration declines:

$$J = \frac{(5.7 \div 0.6) \div (6.5 \div 0.7) \text{ m/s}^2}{(5.7 \div 1.3) \div (6.5 \div 1.5) \text{ m/s}^2} \text{ or } \frac{(89.2 \div 89.5) \%}{(76.9 \div 77.2) \%}$$

(without load/fully loaded).

The braking distance increases in:

$$S_b = \frac{(13.9 \div 105.9) \div (12.5 \div 91.2) \text{ m}}{(13.9 \div 50.5) \div (12.5 \div 44.2) \text{ m}} \text{ or } S_b = \frac{(6.1 \div 6.6)}{(2.4 \div 2.6)}$$

times.

Equally the stopping distance gets increased.

Conclusion

Thus, upon the calculation of the introduced possible options of braking parameters for a two-axle vehicle with the working brake system characterized by different types of malfunctions, a number of principle theses have been derived, which should serve as a guideline when conducting experimental research.

1. It is relevant to perform technical calculations with two values of the starting parameters (in this case,

vehicle deceleration, braking and stopping distances): the minimum permissible and the maximum possible, that is, to use the range of individual parameters included in the calculation formulas, in which the obvious exact value of this or that parameter can be found.

2. When formulating a categorical conclusion, only one value of this or that parameter of the braking efficiency of the vehicle (deceleration, braking and stopping distances) can be used in the calculations: the minimum permissible, if the driver of the vehicle had a technical possibility to prevent the accident by reducing the speed of movement in time, or the maximum possible if he had no technical ability to prevent the accident.

It is necessary to note that making such decision is correct only if in cases of any other values (large in the first case and small in the second) of this or that parameter for the braking efficiency of the vehicle (deceleration, braking and stopping distances) the conclusion made by the expert based on the results of the technical calculations stays unchanged.

3. In cases where the research results are not equal, the expert's conclusion should be also the same, with the reasonable clarification of the decision terms for reaching the verdict.

References

1. Application of Vehicle Braking Parameters (Guidelines for Experts) in Expert Practice RFCFE, 1996, -10 p. (in Russian).
2. Auto-Technical Forensic Examination. A Manual for Expert Auto Technicians, Investigators and Judges. Part 2. Under the Editorship of V.A. Ilarionov. Moscow: All-Russian Research Institute of Forensic Examinations, 1980, - 491 p. (in Russian).
3. Balayan, R.M., Bazikyan, N.A., Simonyan, A.R. (2008). Traffic Accident Expertise in Examples and Problems. Teaching Guide. Yerevan, "Tigran Mets", - 272 p. (in Armenian).
4. Bazikyan, N.A., Balayan, R.M. (2003). Road Traffic Accidents Expertise. Yerevan, Armenian Agricultural Academy, - 215 p. (in Armenian).
5. Bekasov, V.A., Bograd, G.Ya., Zotov, B.L., Indinchenko, G.G. (1967). Automotive Forensic Examination. Legal Literature: M.,- 256 p. (in Russian).

6. Evtukov, S.A., Vasiliev, Ya.V. (2006). Examination of Road Accidents. Handbook. - SPb.: DNK Publishing House, -536 p. (in Russian).
7. GOST R 51709-2001. Vehicles. Safety Requirements for Technical Condition and Verification Methods. - M. GOSSTANDART RF, 2001 (in Russian).
8. Krinitsyn, A.A. (1987). Application of Normative Values of Braking Parameters for Motor Vehicles in Export Practice. Method. Recommendations. All-Russian Research Institute of Forensic Examinations (in Russian).
9. Puchkin, V.A. (2010). Fundamentals of Expert Analysis of Road Traffic Accidents. Database. Expert Technology. Solution Methods. – Rostov-on-Don: IPO PI SFU. - 400 p. (in Russian).
10. Suvorov, Yu.B. (2004). Judicial Road Transport Expertise. Tutorial. Exam “Law and Jurisdiction” M. - 208 p. (in Russian).

Accepted on 02.11.2022

Reviewed on 08.12.2022



UDC 528.8:633.2/.3(479.25)

Peculiarities of Introducing Geoinformation System in the Monitoring Procedure of Rangelands in the Republic of Armenia

T.A. Hovhannisyan, P.S. Efendyan*Armenian National Agrarian University*tigranhov20@gmail.com, armgeoinform@mail.ru

ARTICLE INFO

ABSTRACT

Keywords:

*rangeland,
monitoring,
geoinformation systems,
GPS tracking,
pasture*

Animal husbandry is one of the leading agricultural branches in Armenia. Throughout recent years, almost 40 % of the agricultural gross product is resulted from the animal husbandry branch.

The rangelands play a crucial role in the forage base development. In the recent 30 years the pastures in Armenia have lost their qualitative properties due to overgrazing and degradation thereof, while the land types with the characteristic traits of grasslands are not often used for their intended purpose.

It is practically impossible to implement monitoring over the rangelands without clear and constantly updated information. Such kind of information can be retrieved via the use of geoinformation systems.

Introduction

Rangelands are all those plant-covered areas in the environment, that are most rich in perennial plants, shrub and semishrub vegetation and which are used as a forage base for the management of agricultural production.

Per their intended purpose and significance, the rangelands are divided into two main types: a) pastures and b) grasslands.

The possible and efficient ways of using the rangelands' vegetation cover are related to a number of peculiarities of a specific vegetation cover. Mostly the areas with short-stalked/low-stemmed vegetation cover are used as a pasture, where the main leaf mass of the developing

plants is mostly concentrated at the base of the stalks. As grasslands, such rangelands are used, (meadows), where in the vegetation cover high-stemmed and for the most part uniformly foliated plants developing huge aboveground vegetation mass are dominating (Tovmasyan, 2019).

When using the pastures vegetation cover as a natural resource, at the same time it is necessary to take care of the mentioned resources in view of ensuring their self-restoration and diversity development. The pastures should be used in a way so that to maximally reduce or eliminate the harmful grazing effects. To this end, it is of utmost significance to observe to the grazing standards: times, duration, quantity and rules.

In 1991, after gaining independence the land privatization process launched in Armenia. The grasslands and pastures were also privatized. Physical and legal entities gained the right not only to privatize, but also rent the grasslands and pastures belonging to the state. As a result of overgrazing and degradation, the pastures have been deprived of their qualitative features in the last 30 years, while the land types intended for the use as grasslands are not used for the mentioned purpose.

In the RA, the rangelands are mainly located in piedmont and mountainous zones, where the farmers are mostly engaged in livestock management. There are residences in the piedmont and mountainous zones, where shepherd hiring is a serious problem, as a result of which the grazing of animals takes place without any control, hence upon free grazing; the animals are driven out from the cattle barn in the morning and return in the evening. Currently, there isn't any reliable and relevant information on the actual use, grazing times and directions of the rangelands. The mentioned issue is possible to resolve with the support of geoinformation systems. Geoinformation systems are such information systems, which enable to collect and process comprehensive information and to conduct different types of analyses. GPS receivers ensure the best results for baseline data collection (Calcante, et al., 2019, Sonneveld, et al., 2009, Bao-dong Yuan, et al., 2019, Knight, et al. 2018, Bailey, et al., 2018, David S.Pilliod, et al., 2021, Raizman, et al., 2013, Ungar, et al. 2005, Hyeon T.Kim, et al., 2013, Karl, et al., 2019, Turner, et al., 2000, Safaei, et al., 2018, Barbari, et al., 2006, Williams, et al., 2016, Millward, et al., 2020, Clark, et al., 2006, McCord, et al., 2021, Feldt, et al., 2016, Akasbi, et al., 2012).

Materials and methods

We have set a task to find and develop such technological solutions which would enable to collect and analyze information about the rangelands actually grazed by the community animals. To resolve the mentioned issue the model of RF-V26 for GPS receiver was applied (Figure 1). The technical description of the GPS receiver is introduced in Table 1. The mentioned model is waterproof and the solar panels ensure the duration of working time. The latter was fastened to the cow neck to provide the uninterrupted work of data collection. The investigations started from May, 2019 in the Arzakan community of the RA Kotayk region, the lands of which are located in piedmont zone at an altitude of 1450-1900 m high above sea level. Per the land balance, there are grasslands with 293.02 ha total land area, pastures with 2245.52 ha land area, as well as forest soils with 4236.03 ha land area, certain territories of which

are also used as pastures in September and October. In Arzakan and in the whole Republic of Armenia there isn't any clear information on the factual use of pastures and grasslands. RF-V26 GPS receiver enables to follow cows online, as well as to collect data on the total way the cow passes per day obtaining information on the factual grazing areas. Throughout 2019 and 2021 years we collected data on the factual areas grazed by the cows belonging to the residents of several districts in the Arzakan community.

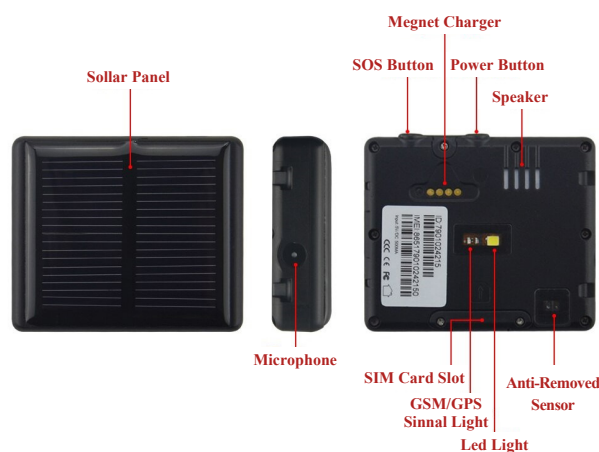

Figure 1. RF-V26 GPS receiver.

Table 1. Technical parameters of GPS receiver*

Model	RF-V26
Types	Tracker, GPS
Material	ABS
Network	GSM, GPRS
Bands	850/900/1800/1900Mhz
GPRS Standard	Class 12, TCP/IP
GPS Accuracy	10-15 m (under the open sky)
Start Time	30 s with cold boot (under the open sky) 29 s with warm boot(under the open sky) 5 s with hot boot (under the open sky)
Battery	1500 mAh
Standby Time	200 hours
Operation Temperature	-20 to +70 degree celsius
Humidity	5-95 percent non-condensing
Weight	64 g

*Composed by the authors.

Results and discussions

RF-V26 enables not only to collect information on the grazing areas of the cows, but also to detect them in the pasture online via phone application. The retrieved data are depicted in Table 2 (<https://gps123.org/>).

The obtained information is introduced on the digital maps in Figure 2.

Table 2. The data retrieved after the cows left the cattle barn*

V26-99399-Details				
From: 2020-08-16 06:40 to: 2020-08-16 20:12				
Position time	Lat	Lon	Speed	Direction
16.08.2020 06:40	40.44264	44.57323	0	124
16.08.2020 06:50	40.44295	44.57269	2.96	301
16.08.2020 07:02	40.44295	44.57269	0	233
16.08.2020 07:11	40.44295	44.57269	0	273
16.08.2020 07:38	40.44286	44.57285	1.28	257
16.08.2020 07:48	40.44286	44.57285	0	333
16.08.2020 07:58	40.4427	44.57341	3.31	255
16.08.2020 08:09	40.4427	44.57341	0	246
16.08.2020 08:19	40.4427	44.57341	0	77
16.08.2020 08:30	40.4427	44.57341	0	219
16.08.2020 08:40	40.44283	44.57309	3.05	264
16.08.2020 08:53	40.44283	44.57309	0	265
16.08.2020 09:09	40.44283	44.57296	2.07	283
16.08.2020 09:19	40.44329	44.57354	2.16	292
16.08.2020 09:30	40.44321	44.57334	2.37	277
16.08.2020 09:40	40.44321	44.57334	0	93

*Composed by the authors.

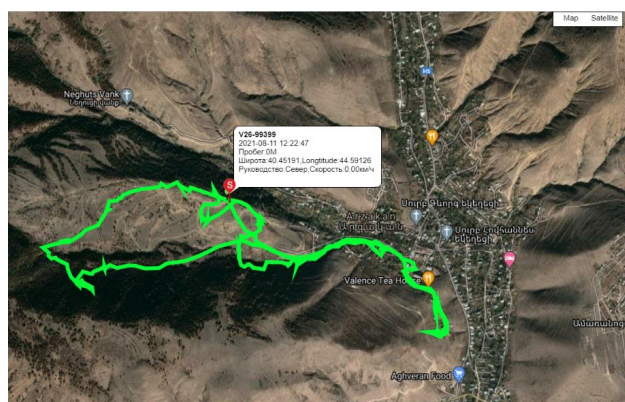

Figure 2. The way a cow walked during a day.

In Figure 2 the movement pattern of a cow in free grazing conditions is clearly viewed. The main issue of free grazing is the absence of shepherd, thus, via the phone application the cow can be detected at any time, if it is required. The example of detection is introduced in Figure 3.

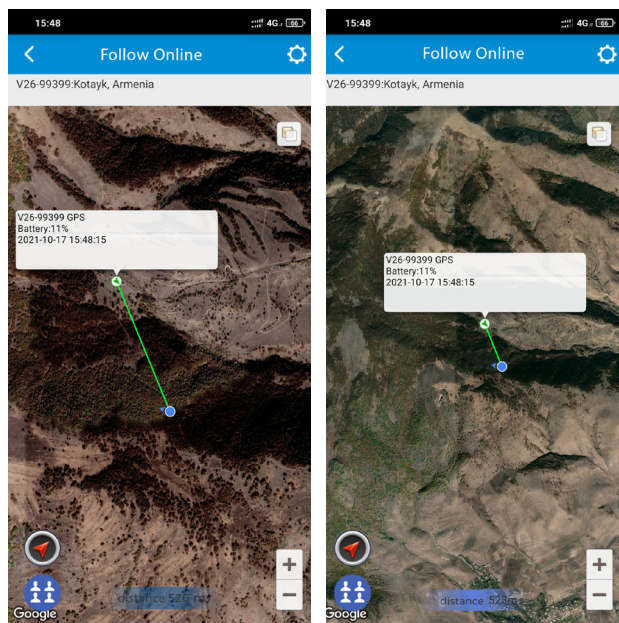

Figure 3. Detection of a cow via phone application.

Information collected throughout 3 years enabled to conduct different types of analyses. Particularly, there is an opportunity to calculate the average distances between the cattle barn and the area where the cow is grazing with straight line, whereby it is observed, that as soon as dry weather conditions are recorded, the cows walk up to 3.5 km away from the cattle barn in September-October (Figure 4) (<https://gps123.org/>).

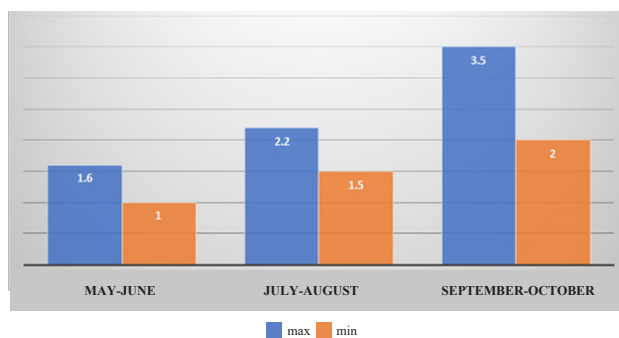

Figure 4. The average distance of the cow in the pasture from cattle barn with straight line in free grazing conditions (day/km) (composed by the authors).

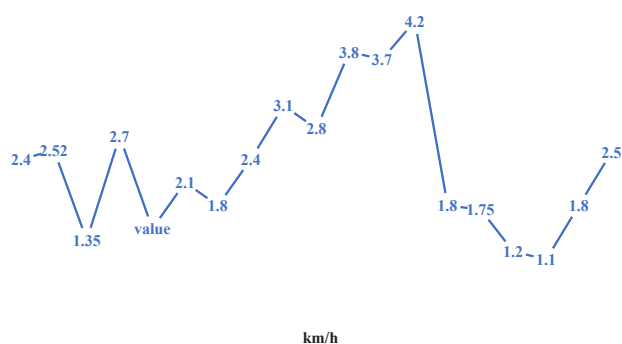

Figure 5. The average cow speed moving to the pasture during the day (composed by the authors).

In Figure 5 the average movement speed of the cow after leaving the barn is introduced. In the result of studying and analyzing the retrieved data we have identified the sites where the cows factually graze and their precise areas.

Collating the obtained spatial data with the cadastral map, we have recorded that for the recent 20 years about 45 ha land areas registered as grasslands in the land balance, have been factually used as pastures starting from May due to free grazing, as a result of which it is impossible to organize hay-mowing in the mentioned areas (Figure 6).

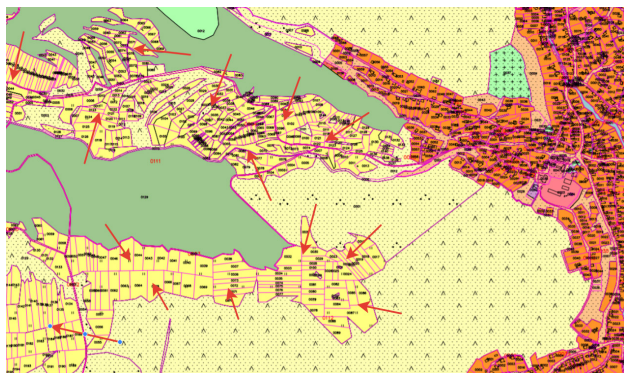

Figure 6. Fragment from the cadastral map of Arzakan, where the grasslands indicated with the arrows are factually used as pastures.

Conclusion

The role of Geoinformation systems in monitoring over the rangelands situated in the piedmont and mountainous zones of the Arzakan and other communities of the Republic of Armenia is indispensable to estimate the factual areas of pastures and grasslands and to combat the problems related to overgrazing. Should the farm households in the rural

communities be equipped with such devices and facilities it will be possible to collect reliable and periodically updated information about the rangelands.

References

1. Akasbi, Z., Oldeland, J., Dengler, J., and Finckh, M. (2012). Analysis of GPS Trajectories to Assess Goat Grazing Pattern and Intensity in Southern Morocco. *The Rangeland Journal* 34(4), - pp. 415–427. <https://doi.org/10.1071/RJ12036>.
2. Bailey, D.W, Trotter, M.G., Knight, C.W., Thomas, M.G. (2018). Use of GPS Tracking Collars and Accelerometers for Rangeland Livestock Production Research Translational Animal Science, Volume 2, Issue 1, - pp. 81-88. <https://doi.org/10.1093/tas/txx006>.
3. Bao-dong Yuan, Sheng-binXie, Bin Liu, Dan-dan Xue, Da-ming Sun (2019). Differential Movement Pattern of Père David's Deer Associated with the Temporal Rhythm Using GPS Collar Fix: Global Ecology and Conservation: Volume 18, e00641, <https://doi.org/10.1016/j.gecco.2019.e00641>.
4. Barbari, M., Conti, L., Koostra, B.K., Masi, G., Guerri, F.S., Workman, S.R. (2006). The Use of Global Positioning and Geographical Information Systems in the Management of Extensive Cattle Grazing: *Biosystems Engineering*, Volume 95, Issue 2, - pp. 271-280. <https://doi.org/10.1016/j.biosystemseng.2006.06.012>.
5. Calcante, A., Tangorra, F.M., Marchesi, G., Lazzari, M. (2014). A GPS/GSM Based Birth Alarm System for Grazing Cows: *Computers and Electronics in Agriculture* Volume 100, - pp. 123-130. <https://doi.org/10.1016/j.compag.2013.11.006>.
6. David, S.Pilliod, Jeffrey, L., Beck, C.J., Duchardt, J. L., Rachlow, Kari E. (2021). Veblen Leveraging Rangeland Monitoring Data for Wildlife: From Concept to Practice: *Rangelands* 12 November 2021. <https://doi.org/10.1016/j.rala.2021.09.005>.
7. Feldt, T., Schlecht, E. (2016). Analysis of GPS Trajectories to Assess Spatio-Temporal Differences in Grazing Patterns and Land Use Preferences of Domestic Livestock in Southwestern Madagascar. *Pastoralism* 6, 5. <https://doi.org/10.1186/s13570-016-0052-2>.
8. GPS Collar Fix: Global Ecology and Conservation: Volume 18, e00641. <https://doi.org/10.1016/j.gecco.2019.e00641>.
9. <https://gps123.org/>. Wireless Communication.

10. Hyeon, T. Kim, Chi, H. Kim, Sang, Y. Lee, Nishizu, T., Kondo, N. (2013). Prediction of the Body Condition with Free Grazing Cattle by the GPS: IFAC Proceedings Volumes, Volume 46, Issue 4, - pp. 346-349. <https://doi.org/10.3182/20130327-3-JP-3017.00078>.
11. Karl, J.W., Sprinkle, J.E. (2019). Low-Cost Livestock Global Positioning System Collar from Commercial Off-the-Shelf Parts: Rangeland Ecology & Management, Volume 72, Issue 6, November 2019, - pp. 954-958. <https://doi.org/10.1016/j.rama.2019.08.003>.
12. Knight, C.W., Bailey, D.W., Faulkner, D. (2018). Low-Cost Global Positioning System Tracking Collars for Use on Cattle: Rangeland Ecology & Management, Volume 71, Issue 4, - pp. 506-508. <https://doi.org/10.1016/j.rama.2018.04.003>.
13. McCord, S.E., Pilliod, D.S. (2021). Adaptive Monitoring in Support of Adaptive Management in Rangelands: Rangelands. <https://doi.org/10.1016/j.rala.2021.07.003>.
14. Michael, F. Millward, Derek, W. Bailey, Andres, F. Cibils, Jerry, L. Holechek (2020). A GPS-Based Evaluation of Factors Commonly Used to Adjust Cattle Stocking Rates on Both Extensive and Mountainous Rangelands: Rangelands, Volume 42, Issue 3, - pp 63-71. <https://doi.org/10.1016/j.rala.2020.04.001>.
15. Patrick, E. Clark, Douglas, E. Johnson, Mark, A. Kniep, Phillip Jermann, Brad Huttash, Andrew Wood, Michael Johnson, Craig McGillivan, Kevin Titus (2006). An Advanced, Low-Cost, GPS-Based Animal Tracking System: Rangeland Ecology & Management, Volume 59, Issue 3, - pp 334-340. <https://doi.org/10.2111/05-162R.1>.
16. Raizman, E.A., Barner Rasmussen, H., King, L.E., Ihwagi, F.W., Douglas-Hamilton, I. (2013). Feasibility Study on the Spatial and Temporal Movement of Samburu's Cattle and Wildlife in Kenya Using GPS Radio-Tracking, Remote Sensing and GIS: Preventive Veterinary Medicine, Volume 111, Issues 1–2, - pp. 76-80. <https://doi.org/10.1016/j.prevetmed.2013.04.007>.
17. Safaei, M., Jafari, R., Bashari, H., Fakheran, S.E. (2018). Mapping and Monitoring of the Structure and Function of Rangeland Ecosystems in Central Zagros, Iran. Environ Monitoring Assessment, 190, 662. <https://doi.org/10.1007/s10661-018-7005-8>.
18. Sonneveld, B.G.J.S., Keyzer, M.A., Georgis, K., Pande, S., Seid Ali, A., Takele, A. (2009). Following the Afar: Using Remote Tracking Systems to Analyze Pastoralists' Trekking Routes. Journal of Arid Environments Volume 73, Issue 11, 10461050. <https://doi.org/10.1016/j.jaridenv.2009.05.001>.
19. Tovmasyan, G. (2019). Manual on Improvement of Degraded Natural Grazing Lands (Pastures and Grasslands), GIZ, Yerevan, - pp 4-25. <https://arot.am/wp-content/uploads/2020/09/Manual-on-Improvement-of-degraded.pdf> (accessed in September, 2022).
20. Turner, L., Udal, M., Larson, B., Shearer, S. (2000). Monitoring Cattle Behavior and Pasture Use with GPS and GIS: Canadian Journal of Animal Science, 80 (2000), - pp. 405-413.
21. Ungar, E.D., Henkin, Z., Gutman, M., Dolev, A., Genizi, A., Ganskopp, D. (2005). Inference of Animal Activity from GPS Collar Data on Free-Ranging Cattle: Rangeland Ecology & Management, Volume 58, Issue 3, - pp. 256-266. [https://doi.org/10.2111/1551-5028\(2005\)58\[256:IOAAFG\]2.0.CO;2](https://doi.org/10.2111/1551-5028(2005)58[256:IOAAFG]2.0.CO;2).
22. Williams, M.L., Parthaláin, N. Mac, Brewer, P., James, W.P.J., Rose, M.T. (2016). A Novel Behavioral Model of the Pasture-Based Dairy Cow from GPS Data Using Data Mining and Machine Learning Techniques: Journal of Dairy Science Volume 99, Issue 3, - pp. 2063-2075. <https://doi.org/10.3168/jds.2015-10254>.

Accepted on 06.09.2022

Reviewed on 31.10.2022



UDC 629.3.067

Diagnostics of Cars' Gas Supply Systems per Tightness Parameters as a Factor of Ensuring Fire Safety

A.R. Simonyan, R.M. Balayan, E.G. Karapetyan, V.A. Shaghoian

Armenian National Agrarian University

arman.simonyan@anau.am, expert.balayan18@gmail.com, eminkarapetyan79@gmail.com, shagoyanv@mail.ru

ARTICLE INFO

Keywords:

gas cylinder vehicle,
gas fuel,
diagnostics,
tightness,
safety system,
gas equipment,
fire safety

ABSTRACT

In order to ensure fire and explosion safety during the operation of gas cylinder vehicles, the control and technical condition of the elements in the vehicle's power system, particularly one of the most important types of operational verification – technical diagnostics of the vehicle through identifying relevant methods and means has been considered in the current article.

It is recommended to install leak detectors with built-in gas flow control sensors in the design of the power supply system of a compressed gas vehicle, which will ensure the detection of gas leaks in the event of depressurization of the car's gas equipment reducing the number of accidents.

Introduction

The persistent increase of the car numbers leads both to a sharp reduction in oil reserves – raw material for fuel production- and the accumulation of toxic substances released from exhaust gases in the environment (Simonyan, 2010). Expanding the material base of liquid fuel and simultaneously reducing the toxic impact on the ecology can only be done at the expense of the so-called unconventional or alternative fuels. Gaseous hydrocarbon fuels, which are environmentally friendly motor fuels, are most widely used in road transport (Yerokhov, 2012). The cost of gas fuel is two to three times lower than the cost of gasoline and diesel fuel, and their raw material reserves exceed those of oil. These factors determine the use of

gas fuel in road transport and large-scale imports of gas cylinder vehicles and the massive retrofitting of gasoline and diesel engines with a gas fuel system without structural changes to the basic models. However, the transition to the use of gas fuel in cars requires implementation of additional works for the installation of gas supply systems, including gas cylinders installation, their maintenance and repairs. The use of gas fuel in automobile transport raises the requirements for maintaining fire safety in the process of operation of gas cylinder automobiles.

In order to meet those requirements, it is necessary to develop such a feeding system, which will enable to warn and exclude the leakage of engine gas fuel during the operation of the car, avoiding possible accidents.

Materials and methods

The advantage of efficient use of gas cylinder automobiles largely depends on the timely and high-quality technical diagnosis in the technical condition of their gas supply systems (RD 3112199-1069-98). One of the main operations of technical fault diagnosis of gas cylinder automobiles is checking the tightness of gas equipment connections, because in case of gas leakage from the fuel system, the probability of fire (explosion) increases significantly. The development and implementation of a safely combined gas supply system with built-in gas flow control sensors that detect (warning) the possible leakage of gas from the gas supply system is of great importance for ensuring the fire safety of gas cylinder vehicles.

Results and discussions

To achieve the main goal of the current work a task has been set up to develop a power supply system so as to ensure the operational safety of gas cylinder automobiles. In order to ensure the safe operation of the cars in the motor vehicle fleet, the inspection of technical condition, especially the operational inspection is of special significance.

One of the important types of operational inspection in the field of technical exploitation is technical fault diagnosis. Technical diagnosis enables to determine the internal technical condition of the car's units, nodes, systems and mechanisms without dismantling at the given time with external and built-in technical means. It solves the problems of car and its units troubleshooting, as well as those of predicting the residual stock.

As studies show (Bazikyan, et al., 2008, Dyukov, 1995), significant research work has been done in the direction of fault diagnosis of fuel system equipment in order to meet the requirements of fuel economy and pollution protection from gases emitted into the environment during the operation of automobiles, but in view of gas cylinder supply system such researches are completely absent, though the technical condition of that system also significantly depends on engine parameters such as: power, fuel consumption, operation quality, stability of work at low rpm during idle time, dynamics of the car, toxicity of exhaust gases, etc.

During the operation of vehicles with a gas cylinder supply system violation of the tightness in the reducer's first and

second stage valves, as well as in the reducer's diaphragm occurs, as well as violation in the second stage valves and in the adjustment of the unloading device spring and shut-off of the high-speed valve in the waste pipe of the gas cylinder is recorded. Therefore, the advantage of efficient use of cars powered by compressed gas largely depends on timely high-quality diagnosis of the technical condition of their gas supply system.

The most common method of checking the technical condition of cars' gas systems is the diagnosis according to the hermetic parameters of working volumes. The point of that method is the detection and quantitative evaluation of gas leaks upon the working volumes of the system (from the gas cylinder, gas reducers, craters, fuel filters, test-measuring devices, as well as connections of all elements of the gas system). When using this method, the subjectivity of the test dominates, that is, the detection of a gas leak due to the neuroleptic abilities (by smell, hearing and vision) of a person – a driver or a checkpoint mechanic, releasing the car on the line and returning it.

Among the existing technical means of checking the tightness of the gas system are the stationary installation TsPKTB-K263, the portable signaling devices "Methane-99", "MSM-2K", "MT-3" (RA Patent 3243A, Simonyan, et al., 2022).

The use of compressed gas – methane or propane-butane mixture – sets special requirements for the safe operation of automobiles (RD 03112194-1095-03, GOST 27577-87).

Each such vehicle, especially if it is a passenger bus, for example, should preferably be equipped with continuous gas leak detection devices. Any motor transport company of the Republic of Armenia, which operates a motor vehicle with a re-equipped gas fuel system, is obliged to have gas flow control indicators for the implementation of regulated checks of the hermeticity of the gas cylinder equipment, because the use of gas fuel increases the fire safety requirements during the operation of motor vehicles.

One of the main processes of diagnosing the faults of gas cylinder automobiles is checking the tightness of connections of all elements in the gas system. To ensure such processes, the authors propose a safe combined gas supply system with built-in gas flow control sensors (Internal combustion engine combined supply system. RA Patent No. 3242A), the scheme of which is shown in the introduced Figure.

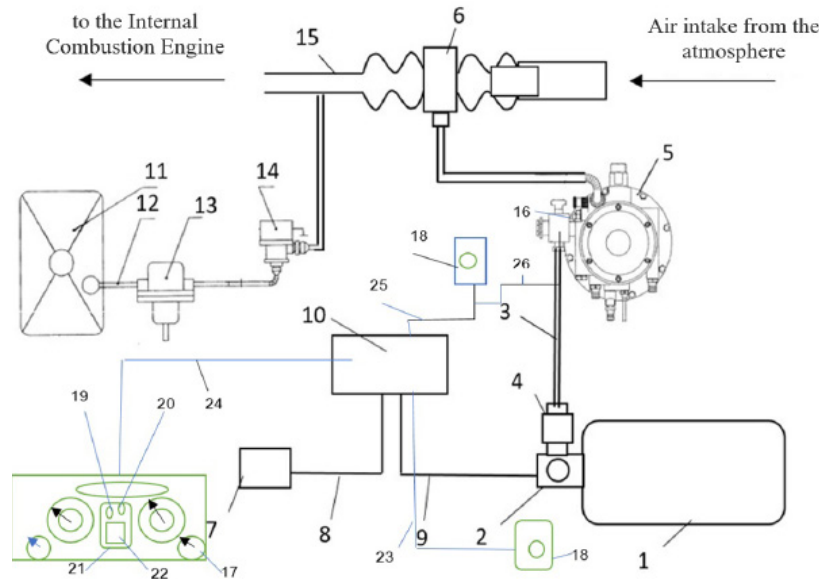

Figure. Diagram of the combined system for safe gas supply (composed by the authors).

The system consists of a high-pressure gas cylinder (1), a mechanical valve (2) and a gas electromagnetic valve (GEV) (4) located between the gas pipe (3), which is calculated to ensure operation at a pressure of 29 MPa and is structurally integrated with the gas filter via one junction, two-stage low-pressure reducer-heater gas reducer (5) and crater (6), of the high-pressure reducer (HPR) (16), which reduces the gas pressure from 20 MPa to 0.5-10.2 MPa, of the shock sensor (SS) (7), which (GEV, HPR, SS) are connected to the electronic control unit (signal processing unit received from pulse sensors) (10) by electrical wires (24), (8) and (9), respectively, which provides sound and light signaling on the control panel in the driver's cabin, disconnection of the gas solenoid valve from the engine stopping, blocking of the engine start, if the pipe of gas filling station is not disconnected from the filling station, as well as transition from gas to gasoline or vice versa, of the gas tank (11), the gas pipe (12), fuel filter (13) electronic gas pump (14) and throttle tube (15), as well as of the sensors (18) that detect the amount of gas and smoke in the atmosphere located under the engine cover and in the passenger compartment, which are connected to the microprocessor control unit and the devices by wires (23) and (25), respectively to the gas leak alarm (21) located on the panel (17), which in turn consists of a liquid crystal

display (LCD) screen (22), LED (19) and a speaker (20).

The system works with the following principle:

In case of gas leakage from the gas cylinder (1) of the vehicle operating via combined supply system or from the gas pipe (3) and upon the connections of two-stage reducer-heater (5) and also in case of smoke, the sensor (18), which detects the amount of gas and smoke in the atmosphere, with a set of wires (23, 25, 26) sends an impulse to the microprocessor block (10), which in turn sends a signal through a set of wires (24) to the gas leakage alarm (21) located on the device panel (17), as a result of which the LED (19) lights up, the speaker (20) works and the gas and smoke amount of the atmosphere appears on the liquid crystal display (LCD) screen (22). Fixing the information about the possible leakage, the system closes the gas electromagnetic valve (10) by means of the microprocessor block (10) and the wire (9), stopping the gas flow from the gas cylinder (1), as a result, automatically converting the gas supply system to gasoline.

With the support of recommended system, it becomes possible to alarm with all available options during the gas leakage of a car with a combined power system, which will create an opportunity to possibly eliminate fire explosion situations as a result of appropriate measures.

Conclusion

A safe combined gas supply system with built-in gas flow control sensors that detect (warning) the possible leakage of motor gas fuel from the gas supply system per the fault diagnosis in hermeticity parameters upon the working volumes in the process of gas cylinder car operation has been recommended, the introduction of which will entail to the reduction of accident numbers (including fires).

References

1. Bazikyan, N. A., Balayan, R. M., Simonyan, A.R., Sargsyan, N.S. (2008). A method of Increasing the Effective Power of Gas Cylinder Engines. *Agrogitutyun* No. 3-4, Yerevan, - pp. 180-182.
2. Combined Power System of Internal Combustion Engine with Gas Import. RA Patent Number 3243A.
3. Dyukov, E. (1995). Ecological Safety - a Strategic Direction / E. Dyukov // *Road Transport*. - № 4, - pp. 40-42.
4. GOST 27577-87. Natural Compressed Gas for LPG Vehicles. - M.: Publishing House of Standards, 1987. - 24 p.
5. Internal Combustion Engine Combined Power System. RA Patent Number 3242A.
6. RD 03112194-1095-03. Guidelines for Organizing the Operation of LPG Cars Working on Compressed Natural Gas. 2003.
7. D 3112199-1069-98. Fire Safety Requirements for Enterprises Operating Motor Vehicles on Compressed Natural Gas. 1998.
8. Simonyan, A. (2010). Natural Gas as Motor Fuel of the 21st Century. "Transport, Ecology-Sustainable Development" XVII Scientific and Technical Conference with International Participation, ECO VARNA 2010.
9. Simonyan, A.R., Mosikyan, K.H., Asoyan, S.A., Shaghoyan, V.A. (2022). Improving Fire Safety System in Gas-Powered Vehicles. *ANAU, Agriscience and Technology*, - N 1 (77), - pp. 28-31. <https://doi.org/10.52276/25792822-2022.1-28>.
10. Yerokhov, V.I. (2012). Gas Cylinder Cars. "Design, Calculation, Diagnostics". M.: Hotline-Telecom, -206 p.

Accepted on 02.11.2022
Reviewed on 09.12.2022



Journal homepage: anau.am/scientific-journal

doi: [10.52276/25792822-2022.4-361](https://doi.org/10.52276/25792822-2022.4-361)

UDC 631.16:338.5:633.11(479.25)

The Analysis of Seasonal Fluctuations and Correlation Between Monthly Average Exchange Rate of Main Currency and Monthly Average Import Prices of the Main Grain in Armenia

V.S. Aleksanyan, G.H. Keshishyan

Armenian National Agrarian University

S.N. Shirokov, I.R. Trushkina

Saint Petersburg State Agrarian University

vardan.aleqsanyan@gmail.com, keshishyan@inbox.ru, shirokovspbgau@mail.ru, auriairina@mail.ru

ARTICLE INFO

Keywords:

*seasonal indexes,
regression analysis,
monthly average import
prices,
non-linear correlation,
positive and negative
correlations*

ABSTRACT

Since 2020 the global economy has faced serious economic and financial challenges due to COVID-19 pandemic. The main purpose of this research is to study the dynamics of the monthly average import prices for the main types of imported grains and monthly average exchange rates for 1 US dollar in 2020-2022 in RA, disclosing the correlation between them. In the studied period the monthly average import price of wheat increased in autumn and in winter months. The results of analysis have shown that in the mentioned period there was a strong non-linear correlation between monthly average exchange rate of 1 US dollar and the average import prices of the main cereals.

Introduction

Since 2020 due to COVID-19 pandemic the global economy has faced serious economic and financial challenges. The second Artsakh war has negatively affected the overall economy of the Republic of Armenia. Throughout the investigation period changes were obvious in the trades between countries, the prices of international trade and in the financial markets as well.

The problem of food safety is the most important issue in food security system of RA. In RA bread consumption per capita exceeds US, Japan and European countries in

2-3 times and it exceeds the global average level by 25 (Bayadyan, 2013). Considering that the increase of self-sufficiency ratio of wheat in RA is of strategic importance, the state support towards the intensification of this sphere is mandatory (Avetisyan, 2010). Since the beginning of the spread of the pandemic in the European continent, many countries have secured their domestic supply and strengthened their stockpiles by increasing the import volumes. This concerns mainly the basic products like flour, soft wheat (in grain), and semolina. The increase was particularly significant in March and April due to high uncertainty in markets and the decision to maintain

a certain stock capacity for several months' consumption. The increase in the consumption of some products put pressure on processors in prices (Impact of the COVID-19 pandemic on agricultural markets and grain sector on the Mediterranean, 2020). The stability of grain prices is considered a key issue for grain security and social stability in many countries. In 2020, the sudden global pandemic of novel coronavirus pneumonia (COVID-19) posed severe challenges to world grain security in many ways. In order to control the spread of COVID-19, all countries around the world took strict isolation measures, which affected the global grain supply system (Shudong Wang, et al., 2022).

The main purpose of this research is to study the dynamics of monthly average import prices for the main types of imported grains and monthly average exchange rates for 1 US dollar in 2020-2022 in RA, upon the disclosure of the correlation between these two phenomena. To achieve this purpose the following problems have been set and solved: studying the seasonal fluctuations of the monthly average import prices for the main cereals and monthly average exchange rate for 1 US dollar in 2020-2022 in RA disclosing the interdependence between the above stated factors with the help of regression analysis.

Materials and methods

The object of this research is the time series of the monthly average import prices for the main grains and monthly average exchange rate of 1 US dollar in 2020-2022 in RA. In the period of 2020-2022 the wheat, barley and maize were the main grains, which were monthly imported into Armenia. During the mentioned period, the other types of grains were imported only several months. The seasonal indexes are used for studying the intra-yearly monthly fluctuation for the sequential year. The seasonal index for each month is calculated as follows:

$$I_{S_i} = \frac{y_i}{\bar{y}} \cdot 100 \% \quad (1)$$

where I_{S_i} is the seasonal index for i -th month, \bar{y}_i is the average of i -th month for studied years, \bar{y} is the average of all studied months (Gusarov, 2003).

The analysis has shown that the correlation between the monthly average exchange rate of 1 US dollar and monthly average import prices of the main grains is best fitted through the polynomial regression model:

$$y_t = a_0 + a_1x_t + a_2x_t^2 + e_t \quad (2)$$

where y_t is the dependent variable, x_t is the explanatory variable, a_0, a_1, a_2 are the parameters, e_t is the residual.

Table 1. The monthly average exchange rate for 1 US dollar and monthly average import prices of wheat, barley and maize within 2020-2022, RA*

Months	Monthly average exchange rate of 1 US dollar, AMD			Monthly average import price of wheat, US dollars			Monthly average import price of barley, US dollars			Monthly average Import price of maize, US dollars		
	2020	2021	2022	2020	2021	2022	2020	2021	2022	2020	2021	2022
January	479.21	521.2	481.78	211.5	232.6	241.3	186.8	132.1	175.4	171.6	187.5	190.2
February	478.74	523.54	480.24	204.3	242.5	232.4	171.0	136.2	198.3	164.7	200.7	196.2
March	489.01	527.67	496.96	177.9	236.6	143.4	122.8	194.4	152.0	154.3	214.2	225.1
April	488.66	525.62	470.99	198.4	211.7	225.5	117.0	275.6	188.9	211.1	204.5	231.9
May	484.12	521.35	456.54	214.9	212.9	294.7	139.0	204.0	212.3	179.7	223.0	274.5
June	481.27	513.09	-	165.1	216.0	-	136.4	142.5	-	176.1	204.8	-
July	484.65	490.87	-	181.3	184.9	-	157.8	141.4	-	176.6	203.2	-
August	485.49	491.73	-	208.4	199.2	-	130.0	155.8	-	202.3	193.8	-
September	486.69	488.12	-	206.4	222.6	-	117.3	159.1	-	176.5	187.4	-
October	491.74	479.25	-	213.9	243.6	-	111.5	151.2	-	170.1	215.1	-
November	499.62	477.66	-	207.2	256.3	-	131.2	160.5	-	187.2	223.4	-
December	518.91	485.14	-	230.8	250.3	-	147.5	170.8	-	190.3	218.7	-

*In 2020-2022 the monthly average import prices for main grains has been calculated by the authors based on their import values and import volumes (Financial statistics of Armenia 2015-2020, social-economic situation of the Republic of Armenia in January-December 2020, social-economic situation of the Republic of Armenia in January-May 2022) (www.armstat.am).

The parameters of regression model are defined by the least square method. The polynomial regression model of 2nd order is mainly applied when the correlation between the dependent and explanatory variables changes within direction of the definite interval. Through this model it's possible to calculate the turning point of independent variable from which the dependent variable changes its direction of development (Yeliseeva, 2014):

$$x_{op} = -\frac{a_1}{2 \cdot a_2} \tag{3}$$

Results and discussions

Shunpeng Wu and Michael A. analyzed the influence of import and export prices on grain market during bubble and non-bubble periods. The annual data of studied indicators had been analyzed from 1960 to 2017 per US data. In the research the monthly export and import price indices, the prices of main grains and monthly Exchange rate of US dollar to CNA has been analyzed. The authors used regression analysis to explore the correlation between these indicators for different periods (Shunpeng Wu Professor Gunderson and Michael, 2020). In most cases the tendency of maize price and maize production volumes have been analyzed using statistical methods and Machine

Learning methods. The linear regression methods have been used also to explore the relationship between the maize price and production volumes (Roterm Zelingher, et al., 2021).

In this research the monthly average exchange rate for 1 US dollar has been considered as an independent variable, and the monthly average import prices of wheat, barley and maize have been considered as explanatory variables.

In 2020-2022 the monthly average import price of wheat mainly declined in March-April and in June-September months. The maximum inflation was in December (Figure 1).

In 2020-2022 the monthly average import price of barley mainly declined in June-November. The growth of average price was in December-May. The maximum inflation was in April (Figure 2).

In 2020-2022 the monthly average import price of maize declined in January-February, in June-July, in September-October. The growth of average price was in spring months and the maximum inflation was in May (Figure 3).

In 2020-2022 the monthly average exchange rate for 1 US dollar increased in January-April, June and December. The maximum monthly average exchange rate for 1 US dollar was in March and the minimum rate in October (Figure 4).

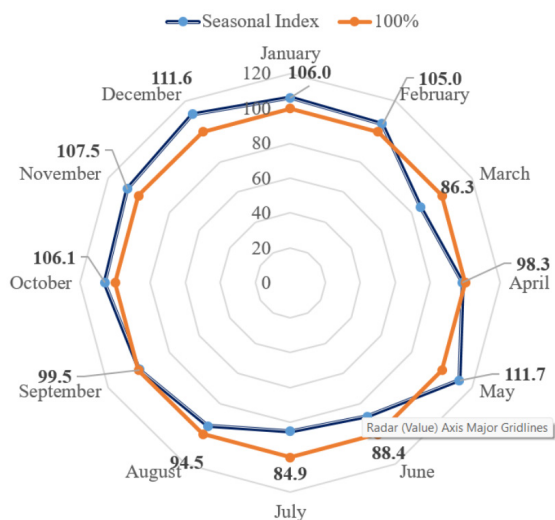

Figure 1. The seasonal indexes of the monthly average import price of wheat in 2020-2022, % (composed by the authors).

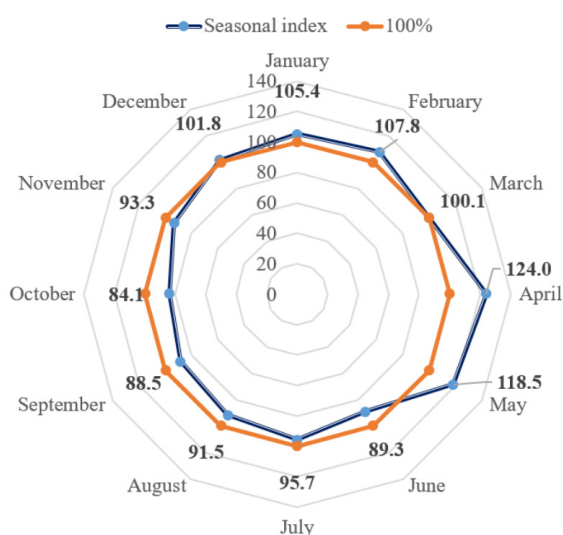

Figure 2. The seasonal indexes of monthly average import price of barley in 2020-2022, % (composed by the authors).

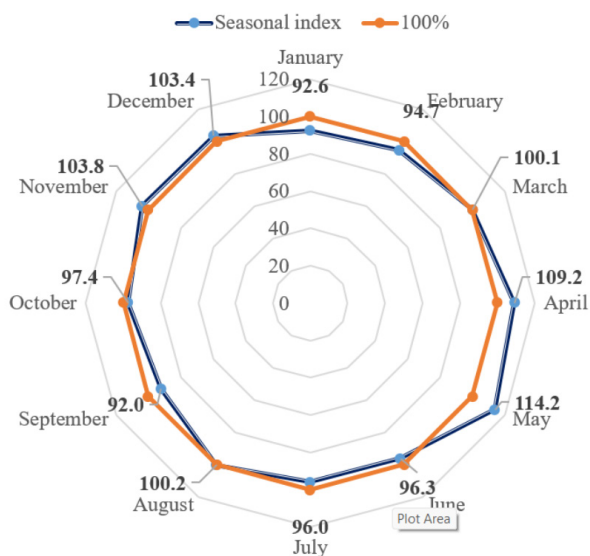

Figure 3. The seasonal indexes of the monthly average import price of maize in 2020-2022, % (composed by the authors).

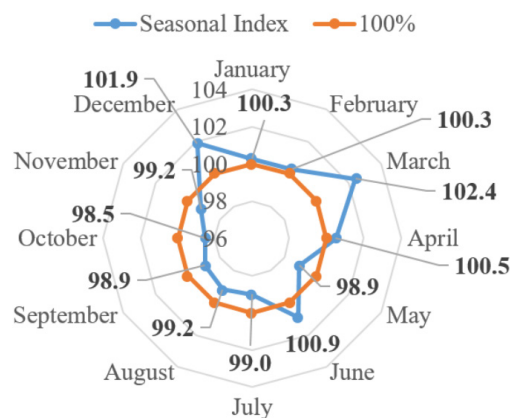

Figure 4. The seasonal indexes of monthly average exchange rate for 1US dollar in 2020-2022, % (composed by the authors).

SUMMARY OUTPUT						
Regression Statistics						
Multiple R	0.66423647					
R Square	0.44121009					
Adjusted R Square	0.39822625					
Standard Error	23.1437133					
Observations	29					
ANOVA						
	df	SS	MS	F	Significance F	
Regression	2	10996.03997	5498.02	10.26456	0.000517882	
Residual	26	13926.41809	535.6315			
Total	28	24922.45806				
	Coefficients	Standard Error	t Stat	P-value	Lower 95%	Upper 95%
Intercept	13877.2266	3033.475855	4.574695	0.000103	7641.827658	20112.63
US dollar (x)	-54.7671239	12.18933993	-4.49303	0.000128	-79.82267091	-29.7116
x^2	0.05480967	0.012232395	4.480698	0.000132	0.029665622	0.079954

Figure 5. Results of regression analysis between the monthly average exchange rate of 1US dollar and the monthly average import price of wheat in 2020-2022 (composed by the authors).

SUMMARY OUTPUT						
Regression Statistics						
Multiple R	0.6196014					
R Square	0.38390589					
Adjusted R Square	0.33651403					
Standard Error	28.856882					
Observations	29					
ANOVA						
	df	SS	MS	F	Significance F	
Regression	2	13491.17799	6745.589	8.100672	0.001842518	
Residual	26	21650.71061	832.7196			
Total	28	35141.8886				
	Coefficients	Standard Error	t Stat	P-value	Lower 95%	Upper 95%
Intercept	15151.3326	3782.308124	4.005843	0.00046	7376.686949	22925.978
US dollar	-60.4361177	15.19835385	-3.97649	0.000497	-91.67678142	-29.19545
x^2	0.06082454	0.015252038	3.987962	0.000482	0.02947353	0.0921756

Figure 6. Results of regression analysis between the monthly average exchange rate for 1US dollar and the monthly average import price of barley in 2020-2022 (composed by the authors).

According to the results of regression analysis, in 2020-2022 there was a strong non-linear correlation between the monthly average exchange rate of 1 US dollar and the monthly average import price of wheat. The results of regression analysis can be considered as significant. According to the results of calculation when the 1 US dollar monthly average exchange rate surpassed 499.6 AMD, the monthly average import price of wheat increased within the period of November 2020 to July 2021 (Figure 5).

According to the results of regression analysis in 2020-2022 there was a strong non-linear correlation between the monthly average exchange rate of 1 US dollar and the monthly average import price of barley. The results of regression analysis can be considered as significant. According to the results of calculation when the monthly average exchange rate of 1 US dollar surpassed 496.8 AMD, the monthly average import price of barley increased from November 2020 to July 2021. (Figure 6).

SUMMARY OUTPUT						
<i>Regression Statistics</i>						
Multiple R	0.6359079					
R Square	0.40437886					
Adjusted R Square	0.35856185					
Standard Error	19.7375191					
Observations	29					
<i>ANOVA</i>						
	<i>df</i>	<i>SS</i>	<i>MS</i>	<i>F</i>	<i>Significance F</i>	
Regression	2	6876.648391	3438.324	8.825955	0.001187439	
Residual	26	10128.81117	389.5697			
Total	28	17005.45956				
	<i>Coefficients</i>	<i>Standard Error</i>	<i>t Stat</i>	<i>P-value</i>	<i>Lower 95%</i>	<i>Upper 95%</i>
Intercept	10994.7959	2587.021663	4.249982	0.000243	5677.096682	16312.495
US dollar	-43.2775361	10.39536425	-4.16316	0.000305	-64.64551336	-21.90956
x^2	0.04330624	0.010432083	4.151255	0.000315	0.021862783	0.0647497

Figure 7. Results of regression analysis between the monthly average exchange rate for 1US dollar and monthly average import price of maize in 2020-2022 (composed by the authors).

According to the results of regression analysis there was a strong non-linear correlation between the monthly average exchange rate of 1 US dollar and the monthly average import price of maize in 2020-2022. The results of regression analysis are significant. According to the results of calculation when the 1 US dollar monthly average exchange rate surpassed 499.6 AMD, the monthly average import price of maize increased from November 2020 to July 2021 (Figure 7).

Conclusion

Throughout the period of 2020-2022 the characteristics of monthly fluctuations for the average import prices of main grains and the average exchange rate for 1 US dollar have been studied through seasonal indices. In 2020-2022 the monthly average import price of wheat increased in January-February and in October to December, the monthly average import price of barley increased from December to May, the monthly average import price of maize increased from March to May, in August, November and in December. Conditioned by the seasonal component in 2020-2022 the monthly average exchange rate of 1 US dollar increased from November to April, as well as in June and December.

The results of analysis have shown that in studied period there was a strong non-linear correlation between monthly average exchange rate of 1 US dollar and the average import prices of main grains. The regression analysis has shown that in 2020-2022, along with the increase of monthly average exchange rate for 1 US dollar the monthly average import prices of wheat, barley and maize

decreased, however, after the definite level of monthly average exchange rate of 1 US dollar within the period of November 2020 to July 2021 their import prices began to gradually increase.

Thus, under the current political and economic situation the non-stable fluctuations of the monthly exchange rate of 1 US dollar make the dynamics of those economic indicators actually unpredictable, but analysis hereby enabled to disclose the regularities of the correlation of studied indicators for short-term period. In this regard, the significant decrease or increase of the monthly exchange rate of 1 US dollar will lead to the increase of the monthly import price of main cereals. This relationship can be a signal for the government to plan relevant activities for the regulation of main cereals import prices. In case when the monthly import prices exceed the yearly average level, the government can apply partial subsidies to control the inflation process.

References

1. Avetisyan, S. (2010). The Agriculture and Agri-Processing of Armenia. Yerevan. LIMUSH Edition, - 233 p. (in Armenian).
2. Bayadyan, A.H. (2013). The Problems and Solving Ways of Agricultural Production Development in RA - Yerevan: NAS, RA "Gitutyun" Edit., - p.144.
3. CIHEAM International Center for Advanced Mediterranean Agronomic Studies. Impact of COVID-19 Pandemic on Agricultural Markets and Grain Sector on the Mediterranean, 2020, Mediterranean Agricultural Market Information Network, - pp. 2-6.
4. Eliseeva, I.I. (2014) Econometrics: Textbook for Master's Students. – M.: Yurayt Publishing House, - 453 p. (in Russian).
5. Finance Statistics of Armenia 2015-2020, Statistical Handbook, SCRA, - 67 p.
6. Gusarov, V.M. (2003). Statistics: - M.: YUNITI-DANA, - 463 p.
7. <https://ag.purdue.edu/departement/agecon/docs/undergraduate/thesis/wu-agec499-final.pdf>.
8. <https://armstat.am/am/?nid=148>.
9. Roterm Zelingher, David Makowski and Thierry Brunelle (2021). Assessing the Sensitivity of Global Maize Prices to Regional Productions Using Statistical and Machine Learning Methods. Frontiers

- in Sustainable Food System, Hypotheses and Theory, - p. 11. <https://doi.org/10.3389/fsufs.2021.655206>.
10. Shudong Wang, Man Zhang, Yuanzhuo Wang, Hui Meng (2022). Construction of Grain Price Determinant Analysis Model Based on Structure Vector of Autoregressive Model, HINDAWI, Scientific Programing, Journal Volume 2022, <https://doi.org/10.1155/2022/5694780>.
 11. Shunpeng Wu Professor Gunderson, Michael A Purdue University (2020). Influence of Import and Export Prices on Grain Market during Bubble and Non-Bubble Periods. Scientific Journal Purdue University, - pp. 17-19.
 12. Social-Economic Situation of the Republic of Armenia in January-December 2020, Monthly Report, SC of RA, Yerevan 2022, - 357 p.
 13. Social-Economic Situation of the Republic of Armenia in January-May 2022, Monthly Report, SC of RA, Yerevan 2022, - 210 p.

The research was carried out with the financial support of the Russian Foundation for Basic Research and the Science Committee of the RA within the framework of the scientific project No. 20-510-05020 \ 20 (No. 20RF-054).

*Accepted on 05.06.2022
Reviewed on 30.11.2022*



UDC 635.11:631.526.32

Evaluation of Morpho-Biological and Phylogenetic Properties of Several Local Populations of Regionalized Beetroot Varieties in Armenia

T.B. Aloyan

Armenian National Agrarian University

tatevaloyan22@gmail.com

ARTICLE INFO

Keywords:

beet,
population,
gene,
morphology,
phylogeny

ABSTRACT

Identifying the variability of plant genetic resources and selecting valuable genotypes is one of the most important problems in plant growing and plant breeding. The research results show that per their morphological and phylogenetic indices the beetroot populations are combined in 2 varieties: Egyptian flat and Bordeaux 237, those of sugar beet – in 1 variety: Belotserkovskaya single-seeded, and fodder beet – in the variety of Yellow Eckendorf. Each of the studied populations has certain advantages per its economic and ecological characteristics, which can be further used in beet breeding.

Introduction

In the contemporary period of advanced agriculture proper evaluation of the crops genetic resources and their further use in breeding activities along with the development and implementation of new intensive technologies is of utmost significance. Identifying the variability of plant genetic resources and selecting valuable genotypes is one of the most important problems in plant cultivation and breeding (Ahmar, et al., 2020). It has been repeatedly mentioned, that genotype is formed throughout the historical development when being in a relatively stable state, which determines the varietal characteristics.

The beetroot under study belongs to *Chenopodiaceae* family. Four beetroot varieties are known in beet breeding:

common beetroot *Beta vulgaris L. var. esculental*, fodder beet *Beta vulgaris L. var. crassa*, sugar beet *Beta vulgaris L. var. saccharifera* and leaf beet (mangold) *Beta vulgaris L. var. vulgaris* and *flavescens* (Melikyan, 2005, Goldman and Janick, 2021).

Beetroot is a typical cross-pollinated plant, it can interbreed freely in nature and produce new forms (Goudarzi, et al., 2019). It has been grown in Armenia since very ancient times, while the regionalized varieties have a history of about 100 years. In the absence of a proper seed breeding system, new populations arise naturally, which are considerably different from the original varieties in terms of their morphological indicators. Since beet seed breeding has not been practiced in Armenia in recent decades, we have not chosen specific varieties as the research object,

but different populations of varieties common in Armenia, which obviously have external differences. Local populations of beet varieties in Armenia are very diverse. Their common characteristics is the similarity of the old forms, which is manifested through the storage root/root crop with roundish form (Melikyan, 2001).

Populations having been cultivated for years in different ecological environments have been selected as research objects (beetroot – Aparan, Aramus, Martuni, Edjmiatsin, Artik, Abovyan and Vardenis, sugar beet – Hrazdan and Artik, fodder beet – Sevan and Shirak).

The current work aims to morphologically characterize the diverse population of the cultivated beetroot varieties, to select valuable populations which can serve as high-value source materials for breeding activities on the way of producing high-performance varieties.

To achieve the goal the following objectives have been set up:

1. Grouping and identifying populations formed from different beetroot varieties per transition periods of phenophases
2. Determining the variability of the main economically valuable characteristics of these populations in different vegetation years
3. Selecting perspective, valuable populations in reference to breeding activities according to bio-economic properties
4. Indicating the phylogenetic relationships between the studied populations according to core and extracore (plastid) genes
5. Recommending the selected best populations as a selective source material.

Materials and methods

For investigations the populations have been selected per their geographic distribution and root crop appearance. Table beet seeds with extremely different root crops were taken from 7 different regions of the RA and sown in conditions of the Voskehat teaching-experimental farm functioning under Armenian National Agrarian University in order to evaluate the plant's morphological and biological characteristics. From sugar and fodder beets two populations each was selected. The experiments were set up throughout 2019-2020 with 11 options per 3 replications. The size of each estimated experimental bed made 25 m². The seeding of the table beet population was implemented with 45 cm interrow and 15 cm intercrop spacing, that of sugar beet population with 45 cm and

25 cm and fodder beet with 50 cm and 30 cm spacing, respectively. The root crops of all population types were planted with the 70x70 cm planting pattern.

Phenological observations were conducted in line with the generally accepted method, every 2-3 days. The collected root crops were planted in the same region as rootstocks in the following year with the same experimental conditions. During the field experiments the plant treatment activities were implemented in accordance with the common agricultural rules.

The leaf area was calculated via scanning and analysis through ImageJ computer software (Schneider, et al., 2012). Yield computation was conducted through weighing the yield of each experimental bed. The mathematical processing of numerical data on yield growth, development and yield calculation was carried out through the method of dispersion analysis developed by Dospekhov.

To identify the populations' phylogenetic relationships, genetic investigations have been carried out in the Holt climate laboratory at the Arctic University of Norway (Tromsø). DNA isolation was performed using the E.Z.N.A.® HP Plant DNA kit (Omega Bio-tek, USA). The concentration of isolated DNA was determined with a NanoDrop 2000 spectrophotometer (Thermo Scientific, USA). Purity was determined on a 1% agarose gel. For nucleotide sequence determination 2 genes widely used in beet phylogenetic studies (Touzet, et al., 2018) were selected: the chloroplast LF gene with 5'-GGTTCAAGTCCCTCTATCCC/5'-ATTTGAACTGGTGACACGAG-3' (forward/reverse) primers and core adh gene with 5'-TGTCCCTGCCCTGTTTTCACTG-3'/5'-TACTGCTCCTAGGCCGAAAA-3' primers. Raw nucleotide sequence data were read, verified, and aligned using the Clustal Omega multiple sequence alignment program (McWilliam, et al., 2013). Aligned sequences were used to construct phylogenetic trees using the maximum likelihood (ML) algorithm implemented via the Mega X program (Kumar, et al., 2018).

Results and discussions

In general, table beet varieties are classified into 5 groups: Egyptian Flat, Egyptian Round, Bordeaux, Eclipse and Erfrut varieties. The beet varieties with flat root crops are usually early-ripening with average shelf life, reddish-purple coloration of fruit pulp and with somewhat pronounced whitish rings. Roundish and flat-roundish root crops ripen later and have longer storage life. Beet varieties with conical root crops are late-ripening with long shelf

life but they contain large amount of cellulose and have fibrous, less juicy fruit pulp (Snappyan, 2001).

For many years a number of beet varieties have been regionalized in the beet breeding farms of Armenia: table beet - Bordeaux 237, Egyptian flat, Egyptian round, sugar beet - Belotserkovskaya single-seeded, Yaltushkovskaya single-seeded, fodder beet – Yellow Eckendorf, Betta Rosa varieties. Anyhow, beet seed breeding hasn't been practiced in our country for already more than 30 years. Considering the fact that beet is a typically cross-pollinated plant, it becomes obvious that decades of cultivation without observing to the rules of seed production can lead to free cross-breeding and the emergence of new forms (Andrello, et al., 2016). Therefore, we have singled out different varietal populations common in Armenia, the appearances of which were prominently different.

To assess the bio-economic values of the variety it is important to study its vegetation duration and the transition period of individual phases. The results of the phenological observations for the first vegetation year of the studied beet populations are introduced in Table 1.

Table 1. The transition periods of phenophases in the studied populations of the regionalized beetroot varieties (the I vegetation year)*

Populations	Seeding	Germination	Leaf rosette formation				Root crop maturation	Vegetation duration, day
			1 true leaf	6 true leaves	12 true leaves	18-20 true leaves		
Table beet								
Aparan	05.04	14.04	02.05	06.06	18.06	08.07	10.08	118
Aramus	05.04	12.04	28.04	26.05	13.06	28.06	02.08	112
Martuni	05.04	15.04	01.05	08.06	19.06	08.07	10.08	117
Ejmiatsin	05.04	13.04	26.04	27.05	11.06	30.06	02.08	111
Artik	05.04	14.04	01.05	08.06	17.06	10.07	10.08	118
Abovyan	05.04	12.04	28.04	27.05	14.06	01.07	02.08	112
Vardenis	05.04	13.04	30.04	03.06	15.06	04.07	10.08	119
Sugar beet								
Hrazdan	05.04	14.04	29.04	01.06	15.06	07.07	20.09	159
Artik	05.04	15.04	02.05	04.06	17.06	09.07	20.09	158
Fodder beet								
Sevan	05.04	14.04	29.04	01.06	15.06	02.07	25.09	164
Shirak	05.04	15.04	02.05	04.06	17.06	09.07	25.09	163

*Composed by the author.

During the first year of life the beet plant usually forms a rosette consisting of 60-90 leaves, anyhow, throughout the whole vegetation period the death of leaves and emergence of the new ones are alternating each other, and hence, the leaf rosette can be loaded with up to 18-20 leaves at a time. The table data show, that the seed germination of the investigated populations was registered mainly in rather close terms with maximum difference of 3 days. Emergence of first true leaves in the leaf rosette was observed within the period of April 26 – to May 2. The table beet population grown in Ejmiatsin was also distinguished by the early formation of the first true leaf. The whole process of leaf rosette formation lasted 61-70 days. Maturation of root crop was recorded about a month after the complete formation of leaf rosette. The 7 studied populations of table beet ripened in 2 periods with an interval of 8 days. Populations of Aramus, Ejmiatsin and Abovyan stood out for their precocity, the vegetation duration of which was 111-112 days. The populations of Aparan, Martuni, Artik and Vardenis were distinguished by 117-119 days of vegetation duration.

The maturation of sugar and fodder beets was delayed by about 30-35 days. There wasn't any significant difference in the duration of vegetation periods among the population varieties.

As we know, quantitative changes occur during individual development periods, which are expressed in the form of growth. This is an irreversible increase in the mass and volume of the plant. During the plants growth and development some qualitative changes take place at a certain age period, which are manifested through the emergence of new organs and well pronounced properties. In the first vegetation year the biometric indices and yield capacity of the studied populations were also determined (Tables 2, 3).

Among the populations of table beet varieties, mainly 2 types of leaves (lamina) were found: oblong and oblong-cordate. Populations with oblong leaves mainly had a smooth surface, while those with oblong-cordate leaves – slightly rough surface. In the populations of sugar beet the leaf lamina was cordate with twisted surface and in fodder beet it was oblong oppositely ovate and slightly wavy.

It is noteworthy that regarding the vegetation period and leaf lamina form the populations of table beet are grouped in 2 categories. The leaf stalks of table beet populations had averagely 15-17 cm length, leaf blades were with 17-19 cm length and 12-14 cm width. The mentioned indices were a bit higher in sugar and fodder beets. There weren't any significant differences between the populations.

Table 2. Morphological indices of the leaves in the studied populations of the regionalized beetroot varieties*

Population	Leaf lamina/blade shape/surface	Leaf stalk length, cm	Leaf lamina length/width, cm	Leaf lamina coloring		Total leaf surface, cm ²		
				At the start of rosette formation	At the harvest stage	At the stage of 6 leaves	At the stage of 12 leaves	At the stage of 18-20 leaves
Table beet								
Aparan	oblong/ slightly wavy	16	19/12	dark green	green-purple	1270	2395	3918
Aramus	oblong-cordate/ smooth	17	17/14	dark green	green-reddish	1152	2325	3511
Martuni	oblong/slightly wavy	15	18/12	dark green	green-purple	1170	2160	3420
Ejmiatsin	oblong-cordate/ smooth	16	17/13	dark green	green-reddish	1220	2439	3205
Artik	oblong/ slightly wavy	15	18/13	dark green	green-purple	1210	2325	3842
Abovyan	oblong-cordate/ smooth	15	17/14	dark green	green-reddish	1384	2489	3624
Vardenis	oblong/ slightly wavy	16	18/13	dark green	green-purple	1290	2380	3900
Sugar beet								
Hrazdan	cordate/ curled	18	18/15	green	green-yellowish	1298	2580	3775
Artik	cordate/ curled	17	19/15	green	green-yellowish	1300	2610	3924
Fodder beet								
Sevan	oblong, oppositely ovate / slightly wavy	23	20/14	dark green	dark green	1530	3075	4890
Shirak	oblong, oppositely ovate /slightly wavy	24	21/15	dark green	dark green	1740	3485	5220

Table 3. The biometric indices and yield capacity of the first year plants in the studied populations of the regionalized beetroot varieties*

Populations	Actual plant number per 1 ha, n	Average weight, g (at harvesting stage)			Root crop			Root crop yield, c/ha
		Total plant	including		diameter, cm	height, cm	index	
			Tops	Root crop				
Table beet								
Aparan	133330 (45x15 cm)	587	247	340	12.0	9.4	0.8	453
Aramus		454	219	235	13.2	7.6	0.6	313
Martuni		580	230	350	10.6	10.3	0.9	467
Ejmiatsin		445	225	220	12.8	5.6	0.4	293
Artik		584	254	330	11.1	10.8	0.9	440
Abovyan		461	216	245	13.5	6.3	0.5	393
Vardenis		585	285	300	11.5	9.0	0.8	400
Sugar beet								
Hrazdan	80000	1203	353	850	13,0	17.0	1.8	680
Artik	(45x25 cm)	1265	345	920	12.5	18.5	1.9	736
Fodder beet								
Sevan	60000	1525	325	1200	16,0	32.5	2.3	720
Shirak	(50x30 cm)	1612	332	1280	17.0	31.2	2.4	768

*Composed by the author.

The main differences in the coloring of leaf lamina were observed at the harvesting stage. The total leaf surface was calculated at the 3rd stage of vegetation. The table beet of Aparan, Artik and Vardenis populations were distinguished by a large leaf surface at the most intense foliation stage. The difference of leaf surfaces among the sugar beet populations is about 150 cm² and in fodder beet – about 330 cm².

The seeding of table beet populations was carried out with 45x15 cm planting pattern, that of sugar beet with 45x25 cm, and fodder beet with 50x30 cm planting patterns. The actual number of plants per 1 ha land area was calculated taking into account the actual number of plants in the experimental bed (Table 3).

The plant weighing was conducted at the harvesting stage. The largest root crops (350 g) were developed in the Martuni population. Aparan, Artik and Vardenis populations stay behind by 10-50 g. The populations of Aramus, Ejmiatsin and Abovyan developed much smaller root crops (220-245 g). The same regularity per populations was observed regarding the top mass. The sugar and fodder beets obviously develop larger root crops. The mass differences between the studied populations made 70-80 g, which is not considered as a significant difference. The characteristic index of the root crop appearance is the root crop index, that is the ratio of height and diameter. The closer the mentioned index to 1 is, the more roundish the root crop is, while the smaller from 1, the flatter its appearance is. The root crops with the index higher than 1 are conical. The studied population of the table beet were combined into 2 groups: those with roundish (0.8-0.9) and flat (0.4-0.6) root crops.

In the sugar and fodder beets conical root crops were developed, besides, in the fodder beet the mentioned property was more pronounced. Considering the actual plant number and the mass of a plant root crop the biological yield of the root crop was calculated. The table beet of Martuni and Aparan populations stood out by their highest yield capacity. The lowest yield capacity was recorded in the Ejmiatsin population, which is probably related not only to the varietal characteristics, but also to the circumstance that Ejmiatsin is not considered as a favorable climatic zone for beet breeding, which can cause to low yield production. The yield capacity difference between the sugar beet populations makes 56 c, and the maximum yield was registered in the Artik population. The fodder beet populations have provided rather close-to-each-other indices.

After harvesting, the root crops were stored in order to continue the studies in the second year of vegetation. In the second year the planting of all options were implemented

with 70x70 cm planting pattern. Here again phenological observations were carried out and the number of days required for seed formation and maturation was registered (Table 4). After root crop planting the leaf rosette per populations was developed in the same period with 1-2 days of differences and lasted about 17-19 days. Flower stems started to develop about 35-40 days after the rosette formation, whereas the mass development was recorded about a month thereafter.

Parallel to the flower stems formation, blossoming process starts, which in the table beet lasted about a month, while in the sugar and fodder beets this period was shorter – about 20 days. The first tops started to ripen 30-40 days after the start of blossoming, whereas the populations of sugar and fodder beet started to ripen much earlier. The mass harvesting of the table beet tops was implemented 130-138 days after planting, that of sugar beet – after 151 days, and the fodder beet – after 152-153 days. It is noteworthy that the populations of the table beet are combined into 2 groups for the second year vegetation indices as it was in the case of the first year results. In the second vegetation year plant measurements and weighing was also implemented (Table 5). In the populations of the table beet 4-5 flower-bearing stems were mainly developed, in the sugar and fodder beets this number was 5. Deviations in the branching number per the species and varieties haven't been recorded; all stems averagely developed 3 branches.

The height of flower-bearing stems fluctuated within the range of 96-121 cm in the table beet populations. The average height of stems in the sugar and fodder beets fluctuated within 114-117 and 125-127 cm, respectively. Here the difference per populations are not significant. The number of developed tops on 1 flower-bearing stem and the weight of tops developed in one plant has been also calculated. As to the numerical calculations, the highest number of tops has been recorded in Aramus population (405 n), but on the whole, the discrepancies in numbers were not significant. In the sugar and fodder beets 444-451 and 448-449 tops have been developed, respectively. Regarding the tops size of table beet populations (per the weight of 1000 tops) those of Vardenis, Aramus and Abovyan were distinguished, anyhow the other populations don't so much stay behind the mentioned ones. There weren't any significant differences between the sugar and fodder beets.

Along with the identification of morphological indices, the nature of inheritance of a number of bio-economic properties is also very important. To this end it is necessary to determine the degree of similarities for the above mentioned 2 groups regarding their genetic systems.

Table 4. The transition periods of phenophases in the studied populations of the regionalized beetroot varieties (II year of vegetation)*

Populations	Planting period	Leaf rosette formation	Emergence of 18-20 leaves in the leaf rosette	Flower stems development	Emergence of the secondary and tertiary flower stems	Mass inflorescence emergence	Blossoming		Maturation of beet tops		Vegetation duration, day
							Start	End	The first ones	Mass	
Table beet											
Aparan	27.03	15.04	20.05	27.05	12.06	28.06	12.06	12.07	23.07	10.08	136
Aramus	27.03	13.04	08.05	18.05	06.06	21.06	11.06	13.07	25.07	04.08	130
Martuni	27.03	15.04	19.05	29.05	14.06	28.06	12.06	13.07	25.07	12.08	138
Ejmiatsin	27.03	13.04	07.05	18.05	06.06	20.06	11.06	11.07	25.07	02.08	128
Artik	27.03	15.04	19.05	29.05	13.06	29.06	13.06	13.07	25.07	12.08	138
Abovyan	27.03	14.04	08.05	19.05	06.06	21.06	11.06	14.07	25.07	04.08	130
Vardenis	27.03	14.04	18.05	27.05	12.06	27.06	13.06	14.07	24.07	10.08	136
Sugar beet											
Hrazdan	27.03	14.04	06.05	18.05	04.06	22.06	03.07	22.07	02.08	25.08	151
Artik	27.03	13.04	07.05	18.05	06.06	20.06	01.07	21.07	02.08	25.08	151
Fodder beet											
Sevan	27.03	13.04	07.05	18.05	06.06	20.06	01.07	21.07	02.08	27.08	153
Shirak	27.03	13.04	07.05	16.05	06.06	19.06	01.07	21.07	01.08	26.08	152

Table 5. The biometric indices of the second year plants in the studied populations of the regionalized beetroot varieties*

Populations	Number of plants per 1 ha, n	Number of a plant's flower-bearing stems, n	Average branching number of a flower-bearing stem, n	Average height of flower-bearing stems, cm	Average top number of 1 flower-bearing stem, n	Weight of 1 plant tops, g	Weight of 1000 tops, g
Table beet							
Aparan	20408 (70x70 cm)	4	3	105	387	42	27
Aramus		4	3	98	405	47	29
Martuni		5	3	121	394	53	27
Ejmiatsin		4	3	100	388	40	26
Artik		4	3	108	391	42	27
Abovyan		5	3	96	393	57	29
Vardenis		4	3	112	385	46	30
Sugar beet							
Hrazdan	20408 (70x70 cm)	5	3	117	444	75	34
Artik		5	3	114	451	79	35
Fodder beet							
Sevan	20408 (70x70 cm)	5	3	125	449	79	35
Shirak		5	3	127	448	83	37

*Composed by the author.

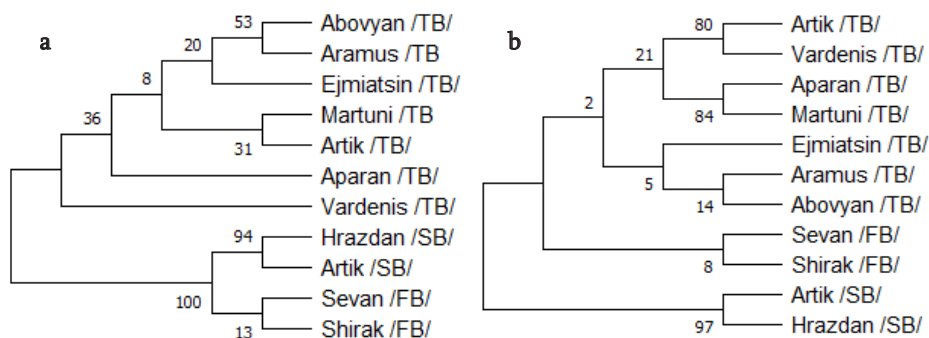

Diagram. Phylogenetic relationships among studied populations of table (TB), sugar (SB) and fodder (FB) beet cultivars according to core adh (a) and extra-core LF (b) genes.

The studies conducted on different varieties in the field of plant genetics prove that besides the hereditary characteristics, the quality of the obtained offspring is also related to the kinship ties between their parents (Zhang, et al., 2017, Wascher, et al., 2022). For this reason, a study on the phylogenetic relationships of the studied populations was also performed. Since in addition to the core genes there are also extra core genes in the plant cell, which can determine the hereditary nature of this or that trait, we have selected 1 core (adh) and 1 extra core, particularly chloroplast genes (LF) (Diagram).

The data of diagram make it obvious that the sugar and fodder beets are distinguished from the table beet both by core and extra core genes and that at the same time there are similarities between the populations. In case of table beet, formation of 2 groups is observed for both genes. The phylogenetic depiction once again confirms the results of the morphological studies, stating that 4 table beet populations belong to the Bordeaux 237 variety and 3 - to the Egyptian flat, and 2 sugar and fodder beet populations belong to 1 variety each, Belotserkovskaya single-seeded and Eckendorf Yellow, respectively.

Conclusion

Based on the morpho-biological and phylogenetic features of populations the following conclusions can be drawn:

1. Aramus, Abovyan and Ejmiatsin populations of table beet were developed from Egyptian flat, whereas Aparan, Martuni, Vardenis and Artik populations - from Bordeaux 237 varieties. The Hrazdan and Artik sugar beet populations

were developed from the Belotserkovskaya single-seeded variety, and the Sevan and Shirak fodder beet populations were formed from the Eckendorf Yellow variety.

2. Each of the investigated populations has a certain advantage in terms of their economic and ecological properties: the Ejmiatsin population of the table beet is the most early-ripening variety, while the Martuni population is the most productive one. The populations of sugar and fodder beet varieties haven't demonstrated significant differences regarding their ecological and economic properties.

Based on the above stated conclusions and kinship ties disclosed between the populations it is recommended to use the afore mentioned populations which will provide high cross-breeding efficiency in order to produce early-ripening and high-yielding varieties in selection.

References

- Melikyan, A.Sh. (2001). Biological Features of a Number of Wild Vegetable Plants Common in Armenia and their Application Possibilities. Yerevan, Gaisan, - 171 p. (in Armenian).
- Melikyan, A.Sh. (2005). Vegetable Growing. Yerevan, Edit Print LLC, - 503 p. (in Armenian).
- Snappyan, G.G. (2001). Refrigeration Technology of Fruits and Vegetables. Yerevan, Asoghik, - 342 p.
- Ahmar, S., Gill, R.A., Jung, K.H., Faheem, A., Qasim, M.U., Mubeen, M. & Zhou, W. (2020). Conventional and Molecular Techniques from Simple Breeding to Speed

- Breeding in Crop Plants: Recent Advances and Future Outlook. *International Journal of Molecular Sciences*, 21(7), 2590. <https://doi.org/10.3390/ijms21072590>.
5. Andrello, M., Henry, K., Devaux, P., Desprez, B., Manel, S. (2016). Taxonomic, Spatial and Adaptive Genetic Variation of Beta Section Beta. *Theor. Appl. Genet*, 129, - pp. 257–271.
 6. Goldman, I.L., & Janick, J. (2021). Evolution of Root Morphology in Table Beet: Historical and Iconographic. *Frontiers in Plant Science*, 12, 689926. <https://doi.org/10.3389/fpls.2021.689926>.
 7. Goudarzi, F., Hemami, M.R., Rancilhac, L., Malekian, M., Fakheran, S., Elmer, K.R., Steinfartz, S. (2019). Geographic Separation and Genetic Differentiation of Populations are not Coupled with Niche Differentiation in Threatened Kaiser's Spotted Newt (*Neurergus kaiseri*). *Sci. Rep.* 9, 6239, <https://doi.org/10.1038/s41598-019-41886-8>.
 8. Kumar, S., Stecher, G., Li, M., Knyaz, C., and Tamura, K. (2018). MEGA X: Molecular Evolutionary Genetics Analysis across Computing Platforms. *Molecular Biology and Evolution*, 35, -pp. 1547-1549.
 9. McWilliam, H., Li, W., Uludag, M., Squizzato, S., Park, Y. M., Buso, N., Cowley, A. P., & Lopez, R. (2013). Analysis Tool Web Services from the EMBL-EBI. *Nucleic Acids Research*, 41(W1), W597–W600. <https://doi.org/10.1093/nar/gkt376>.
 10. Schneider, C.A., Rasband, W.S., & Eliceiri, K.W. (2012). NIH Image to ImageJ: 25 Years of Image Analysis. *Nature Methods*, 9(7), 671–675. <https://doi.org/10.1038/nmeth.2089>.
 11. Touzet, P., Villain, S., Buret, L., Martin, H., Holl, A.C., Poux, C., & Cuguen, J. (2018). Chloroplastic and Nuclear Diversity of Wild Beets at a Large Geographical Scale: Insights into the Evolutionary History of the Beta Section. *Ecology and Evolution*, 8(5), 2890–2900. <https://doi.org/10.1002/ece3.3774>.
 12. Wascher, F.L., Stralis-Pavese, N., McGrath, J.M., Schulz, B., Himmelbauer, H., & Dohm, J.C. (2022). Genomic Distances Reveal Relationships of Wild and Cultivated Beets. *Nature Communications*, 13(1), <https://doi.org/10.1038/s41467-022-29676-9>.
 13. Zhang, Y.F., Li, G.L., Wang, X.F., Sun, Y.Q., Zhang, Sh.Y. (2017). Transcriptomic Profiling of Taproot Growth and Sucrose Accumulation in Sugar Beet (*Beta vulgaris* L.) at Different Developmental Stages. *PloS one*, 12(4), e0175454. <https://doi.org/10.1371/journal.pone.0175454>.

Accepted on 12.10.2022

Reviewed on 21.10.2022



UDC 633:631.531.02(479.25)

Identification of Species Composition of Harmful Entomofauna in Seed Storehouses of Some Field Crops

A.J. Ter-Grigoryan, A.A. Manvelyan, M.H. Ghazaryan

Armenian National Agrarian University

armenak.tergrigoryan@gmail.com, armjes77@mail.ru, maga-ghazaryan@mail.ru

ARTICLE INFO

Keywords:

pest,
warehouse,
injury,
seed,
crop

ABSTRACT

In 2018-2019, 8 species of pests were registered in the warehouses of seeds of different crops, which were located in the cities of Yerevan, Abovyan and Masis, (*Sitophilus granaries* L., *Trogoderma granarium* Ev., *Tenebrioides mauritanicus* L., *Sitophilus oryzae* L., *Rhyzopertha dominica* F., *Acanthoscelides obtectus* Say., *Callosobruchus maculatus* Fabr., *Sitophilus oryzae* L., *Bruchophagus roddi* Guss). In all three warehouses, wheat and barley were the most infected with pests, while sainfoin was not damaged in any of the warehouses.

Introduction

The high yield of each crop and qualitative characteristics are determined by its seed properties. Seed is the bearer of all the economic and biological features of the variety. The quality of seed depends to a large extent on both cultivation and storage conditions.

One of the important factors influencing the quality of seeds is the creation of necessary conditions for their storage in warehouses. Storage of grain under membrane in enclosed areas often contributes to the development of barn pests, as there is a favorable microclimate and a rich selection of food.

If, as a result of insufficient ventilation, the temperature and humidity of the warehouse increase, reaching the optimal conditions for the development of the pests in the

warehouse, then their massive reproduction is expected. The rate of pest damage in stored seeds varies greatly, which depends not only on the geographical location, storage method and quantity of stocks, but also on the species composition of pests, the nature and degree of harm caused by them. The most damage is caused by those types that lead a hidden life, feed on the endosperm and spend their entire lives inside the grain.

Materials and methods

The studies were conducted in 2018-2019 in the warehouses of seeds of different field crops, which were located in the cities of Yerevan, Abovyan and Masis.

The object of the research was the stored seeds, and the aim was to identify the taxonomic composition of pests

therein. In order to identify harmful entomofauna, visual, biological, staining methods accepted in entomology were implemented. Sampling was carried out in accordance with the RA Government's Decree No. 514-N of April 8, 2004 and in line with the procedure of "Providing test samples for phytosanitary examination". The process was carried out in the warehouses under study from seed material packages – bags.

Spot sampling of seed material was performed from each batch. Each spot sample of large-seeded crops should be 20-25 grams, and small-seeded crops should be no less than 10 grams. Spot sampling of stored seed material is done from 5 points. At each indicated point, point samples were taken from 3 layers (www.arlis.am). Samples were taken from different sections and then an average sample was formed, for each layer separately. If there are damaged grains on the surface of the mound and larval molting, then these pieces were selected by hand and attached to the middle sample (www.docs.cntd.ru). The samples of the taken seeds were taken to the laboratory and the species of pests therein were detected with the help of determinants.

Results and discussions

The research was conducted in 2018-2019, in the seed warehouses of various crops, where the seeds of alfalfa, sainfoin, wheat, barley, beans, cicer, peas, buckwheat and corn were stored. Research has shown that some of the seeds in the same warehouse were not infected with pests at all, while others were very strongly infected. The following types of pests have been registered:

1. *Sitophilus granaries* L. (www.cabi.org, www.pesticidy.ru)
2. *Trogoderma granarium* Ev. (Agapova, 2012)
3. *Callosobruchus maculatus* Fabr. (Agapova, 2012, A Handbook on Bean Beetles, *Callosobruchus maculatus*, 2014)
4. *Acanthoscelides obtectus* Say (Akhremovich, et al., 1976)
5. *Tenebrioides mauritanicus* L. (www.agroxxi.ru)
6. *Sitophilus oryzae* L. (Akhremovich, et al., 1976)
7. *Rhizopertha dominica* F. (Alesho, et al., 2015, www.pesticidy.ru)
8. *Bruchophagus roddi* Guss. (Akhremovich, et al., 1976, www.agroatlas.ru).

The survey results are presented in Tables 1-3.

Table 1. Species composition of pests found in the seed warehouse of the Masis city*

Crop	Pests							
	<i>Sitophilus granarius</i> L.	<i>Trogoderma granarium</i> Ev.	<i>Callosobruchus maculatus</i> Fabr.	<i>Acanthoscelides obtectus</i> Say	<i>Tenebrioides mauritanicus</i> L.	<i>Sitophilus oryzae</i> L.	<i>Rhizopertha dominica</i> F.	<i>Bruchophagus roddii</i> Guss.
Wheat	+	+	-	-	+	+	+	-
Barley	+	+	-	-	+	+	+	-
Buckwheat	-	-	-	-	-	-	-	-
Corn	-	-	-	-	-	+	-	-
Cicer	-	-	+	+	-	-	-	-
Peas	-	-	+	+	-	-	-	-
Sainfoin	-	-	-	-	-	-	-	-
Alfalfa	-	-	-	-	-	-	-	+

*Composed by the authors.

From the data of Table 1 it can be seen that in the considered seed warehouse, the most species composition of pests was recorded in wheat and barley seeds (*Sitophilus granaries* L., *Trogoderma granarium* Ev., *Tenebrioides mauritanicus* L., *Sitophilus oryzae* L., *Rhizopertha dominica* F.) (Figure 1), then – in cicer, peas (*Callosobruchus maculatus* Fabr., *Acanthoscelides obtectus* Say.), while corn seeds were infected with one type of pest each.



Figure 1. Batch of barley and wheat seeds infected with pests in the seed warehouse of the Masis city.

Table 2. Species composition of pests found in the seed warehouse of the Abovyan city*

Crop	Pests				
	<i>Sitophilus granaries L.</i>	<i>Trogoderma granarium Ev.</i>	<i>Tenebrioide mauritanicus L.</i>	<i>Sitophilus oryzae L.</i>	<i>Rhizopertha dominica F.</i>
Wheat	+	+	+	+	+
Barley	+	+	+	+	+
Buckwheat	-	-	-	-	-
Corn	-	-	-	+	-
Sainfoin	-	-	-	-	-

*Composed by the authors.

**Figure 2.** Batch of barley and wheat seeds infected with pests in the seed warehouse of the Abovyan city.

From the data in Table 2 it can be seen that in the seed warehouse of the Abovyan city, as in the seed warehouse of Masis, wheat and barley seeds were infected with the most types of pests (*Sitophilus granaries L.*, *Trogoderma granarium Ev.*, *Tenebrioide mauritanicus L.*, *Sitophilus oryzae L.*, *Rhizopertha dominica F.*) (Figure 2), whereas corn was infected with one type of pest.

From the data in Table 3, it becomes clear that in the Yerevan seed warehouse, as in the previous 2 warehouses, wheat and barley seeds were again infected with the most types of pests (*Sitophilus granaries L.*, *Trogoderma granarium Ev.*, *Tenebrioide mauritanicus L.*, *Sitophilus oryzae L.*, *Rhizopertha dominica F.*) (Figure 3), then cicer,

peas (*Callosobruchus maculatus Fabr.*, *Acanthoscelides obtectus Say.*) and corn (*Rhizopertha dominica F.*, *Sitophilus oryzae L.*), alfalfa (*Bruchophagus roddi Guss.*) was infected with one pest each and again no damage and pest presence was observed on onobrychis.

Table 3. Species composition of pests found in the seed warehouse of Yerevan*

Crop	Pests							
	<i>Sitophilus granaries L.</i>	<i>Trogoderma granarium Ev.</i>	<i>Callosobruchus maculatus Fabr.</i>	<i>Acanthoscelides obtectus Say.</i>	<i>Tenebrioide mauritanicus L.</i>	<i>Sitophilus oryzae L.</i>	<i>Rhizopertha dominica F.</i>	<i>Bruchophagus roddi Guss.</i>
Wheat	+	+	-	-	+	+	+	-
Barley	+	-	-	-	+	+	+	-
Corn	-	-	-	-	-	+	+	-
Cicer	-	-	+	+	-	-	-	-
Peas	-	-	+	+	-	-	+	-
Sainfoin	-	-	-	-	-	-	-	-
Alfalfa	-	-	-	-	-	-	-	+

*Composed by the authors.

**Figure 3.** Batch of barley and wheat seeds infected with pests in the seed warehouse of the Yerevan city.

Conclusion

Thus, in 2018-2019, when examining the seed warehouses of different field crops located in the Yerevan, Abovyan and Masis cities, we have identified 8 types of storage pests (*Sitophilus granaries L.*, *Trogoderma granarium Ev.*, *Tenebrioide mauritanicus L.*, *Rhizopertha dominica F.*, *Callosobruchus*

maculatus Fabr., *Acanthoscelides obtectus* Say., *Sitophilus oryzae* L., *Bruchophagus roddi* Guss.), 7 of which were representatives of the Coleoptera class, and one – of Hymenoptera. In all three warehouses wheat and barley seeds were infected with the most types of pests and the onobrychis was not damaged in any warehouse.

References

1. Alesho, N.A., Provorova, I.N., Kaira, A.N. (2015). Beetles - Pests of Materials and Food Stocks (Species Composition, Biology, Ecology, Sanitary and Epidemiological Significance, Control Methods), Textbook Moscow, - pp. 21-22 (in Russian).
2. Atlas of Quarantine Pests, Plant Diseases and Weeds, the Most Dangerous for the Territory. Krasnoyarsk Region. / Ed. A.M. Agapova. - Krasnoyarsk: Special Press, 2012. Art. 16-17, - pp. 10-11 (in Russian).
3. Akhremovich, M.B., Batiashvili, I.D., Bei-Bienko, G.Ya. (1976). Key to Agricultural Pests by Damage to Cultivated Plants. Ed. G. E. Osmolovsky. - L.: Kolos, - p. 83; 47; 104 (in Russian).
4. A Handbook on Bean Beetles, *Callosobruchus Maculatus* Christopher W. Beck Department of Biology, Emory University christopher.beck@emory.edu and Lawrence S. Blumer Department of Biology, Morehouse College lawrence.blumer@morehouse.edu 2014, - p. 17.
5. <https://docs.cntd.ru/document/1200024347> (accessed on 22.05. 2021).
6. <https://www.cabi.org/isc/datasheet/10850#0EB6197A-3547-4CFE-B9FD-4E0E06AA38DB> (accessed on 04.08.2022).
7. https://www.pesticity.ru/Долгоносик_амбарный (accessed on 10.10.2022).
8. http://www.agroatlas.ru/ru/content/pests/Bruchophagus_roddi/index.html (accessed on 06.02.2022).
9. https://www.pesticity.ru/Точильщик_зерновой (accessed on 30.09.2021).
10. <https://agroxxi.ru/goshandbook/wiki/Козьякмавританская.html> (accessed on 10.06.2022).
11. <https://www.arlis.am/DocumentView.aspx?docid=12372> (accessed on 03.12.2021).

Accepted on 10.11.2022
Reviewed on 07.12.2022



UDC 635.646:631.559+635.649:631.559(479.25)

The Influence of Hail Protection Net Application on the Yield Capacity and Quality of Eggplant and Pepper in Conditions of Ararat Valley, RA

G.A. Tovmasyan, R.N. Nazaryan

Armenian National Agrarian University

tarnild1@rambler.ru, rudiknazaryan@yahoo.com

ARTICLE INFO

Keywords:

*eggplant,
pepper,
hail protection net,
shading,
cultivation*

ABSTRACT

To obtain high quality and abundant yield product from vegetable crops, it is necessary to improve cultivation technology by applying new agricultural measures and introducing modern agricultural systems, which will allow to obtain competitive products in the market at low costs. Research has been carried out at the ANAU Voskehat experimental farm in 2022. During the research respective eggplant and pepper varieties were cultivated in open field with hail protection net shading. The experimental data showed that net shading had positive effect on the growth, development, quantity and quality of eggplant and pepper yield, providing 45 and 22 c per-hectare yield surplus, respectively.

Introduction

In Armenia vegetable crops are grown in all agricultural zones, but the Ararat valley remains the main specialized zone for vegetable cultivation, where, according to long-term average data, more than 65 percent of vegetable crops are planted (Grigoryan, 1999). For many economic entities of the republic the vegetable growing is considered the main production area and plays a major role in both agriculture and the entire economy of the country.

According to the data of the RA National Statistical Committee, in 2021 the cultivated areas of vegetable crops in the republic amounted to 21.3 thousand hectares, which is 9.6 % of the total cultivated areas. A total of 692.8 thousand tons of vegetables were produced, which were mainly consumed in the local market, and also exported (Statistical Yearbooks, 2021).

Vegetable crop cultivation is among the advanced branches of the agricultural system, since being intensive crops, they require a large amount of resources per hectare, such as irrigation water, fertilizers, machinery, transportation, etc. Therefore, they contribute to increasing the level of agricultural intensification, soil fertility, and the yield of subsequent crops (Balashev and Zeman, 1981, Krug, 2000, Andreyev, 2003). Herewith, cultivation of vegetables is also associated with significant difficulties, as most vegetables are considered to be perishable products, their treatment is labor-consuming, transportation is difficult; besides, they require quick harvesting and marketing (Grigoryan, 1999, Melikyan, 2005).

Increasing the efficiency of vegetable crops cultivation is a necessary condition for enlargement of sowing areas and involvement of new species and varieties in cultivation.

From this point of view, it is necessary to continuously improve cultivation technologies, apply new agromasures, regionalize new varieties and hybrids and to contribute modern agricultural systems, the application of which will enable to obtain low-cost and competitive products in the market. Anyhow, in Armenia, in order to introduce new crops or new technologies into production, first of all it is necessary to prove their advantages over traditional crops or technologies to the farmers, which we have tried to do throughout our research activities.

Materials and methods

The study was conducted within the framework of the joint program “Intitutional strengthening-demonstration field in the Armavir region” implemented by Armenian National Agrarian University and National Institute of Agricultural Technology, Argentina (INTA).

Using INTA’s practice, during the vegetation period of 2022 innovative technologies for growing agricultural crops were experimented in the area of 850 m altitude above sea level, allocated in the Voskehat teaching-experimental farm of ANAU.

Eggplant variety of “Hoktemberyan 3” and pepper variety of “Nush 55” were cultivated under the shading of hail protection net and without it in the open field. The height of the net from the ground surface was 2.8 m, the vertical parts of the field edges were open and the nets were raised.

In all experimental plots under study a drip irrigation system was installed through which the crops were irrigated and regularly nurtured during the entire vegetation period.

In all experimental plots the inter-row spacing of crops was 60 cm and the inter-plant spacing was 40 cm. This is due to the scheme of efficient field surface use and irrigation system. The precursor during the previous cultivation was cucumber.

The experiments were carried out with 2 variants in 3 replications and the calculated area of one experimental bed was 144 (9.6 x 15) square meters. Eggplant and pepper seedlings were received from the Scientific Centre of Vegetable and Industrial Crops of the RA MoE. For planting eggplant seedlings (45-day-old with 20-25 cm height) and pepper seedlings (45-day-old with 18-20 cm height) were transported to the experimental field without pots. Seedlings were sorted before planting. Only healthy, thick-stemmed seedlings were planted and the rest were rejected. Seedlings of eggplant and pepper were planted on May 18-22, 2022 in all experimental plots. Parallel to planting, the first irrigation was implemented through

drip irrigation system. A week after planting recovery work was carried out in the experimental beds: dried out seedlings were replaced by new ones in order to ensure full vegetation cover.

The same treatment activities were carried out in all experimental plots: weeding and hoeing – 5 times, irrigation – every 3-4 days in the evenings, starting from the planting period up to 10 days before harvest, control over diseases and pests with chemical preparations, feeding 3 times with the dose of $N_{20}P_{20}K_{20}$, together with irrigation. During the vegetation period phenological observations and biometric measurements were carried out, according to the accepted methodology for field experiments (Dospekhov, 1985). The final harvest date for all variants has been set up as October 21st.

The first harvesting was implemented at the stage of fruits technical maturity, then it continued regularly once or twice a week. Harvesting in the pepper fields went on also at the stage of fruits biological ripening: the red fruits of pepper were collected.

The commodity groups of the yield were determined according to the EEC UN standards, based on which they were divided into the first and second groups. Non-standard fruits were left out from yield accounting (UNECE standard ffv-05 - 2017).

Short description of the tested eggplant and pepper varieties

Hoktemberyan 3 /eggplant/. The mentioned variety was bred through local population selection. It is a mid-season variety, it takes 110 days from mass sprouting to technical maturity, while biological maturity lasts 132 days. The variety is recommended to be cultivated in open ground conditions.

The plants are clustered, the average height is 65 cm, the width is 45 cm. The stem is free of thorns. The leaves are large, elongated oval and without thorns. The fruits are large, oblong-cylindrical, dark purple, with a shiny surface. The average fruit length is 22.5 cm, width is 6.3 cm and the average weight is 310g. The flesh is delicate, spongy, white, the taste has no bitterness. The total yield capacity is 720 tons/ha. The variety is relatively resistant to diseases.

Nush 55 /pepper/. This variety was produced through mutagenesis, from Lastochka variety. It is an early maturing indeterminate variety. The period from germination to the technical ripening of the fruits lasts 95-105 days. The fruits are conical, large, with a broad base. The mass of fruits at the technical ripening stage is 70-80 g and in the stage of biological ripening their weight is 80-90 g.

At the stage of technical ripening, the fruits are green, at the stage of biological ripening – red. Dry matter is 4.5-5.8 %, biological matter is 6.8-7.4 %. The yield is up to 500 c/ha. The fruits are used fresh and processed.

Results and discussions

When choosing the patterns of vegetable crops planting, it is necessary to take into account their feeding area, which is determined per the plant's requirements and, of course, according to the working parts and wheels of the machine tools, as well as the capture width (Melikyan, 2005, Krug, 2000, Andreyev, 2003). In our experimental plots the inter-row spacing for eggplant and pepper was 60 cm, based on the above stated conditions and the possibilities of irrigation system operation. The system was installed in rows with a distance of 60 cm, the drippers were opened at 40 cm intervals. Taking into account that eggplant and pepper are light-demanding crops (Melikyan, 2005, Sarukhanyan, 2016, Andreyev, 2003), such a feeding area provided sufficient light conditions and reduced the negative impact of plants mutual shading. The requirement of seedlings per one hectare was about 41600 items.

Eggplant and pepper seedlings were planted in the test plot on May 18-22 related to weather conditions. The high heat demand of eggplant and pepper was taken into account, as well as the effective temperature background (22-25 degrees)

for plant growth in that period. In such temperature conditions the seedlings spend only 30 % of assimilation substances for respiration and excretion of substances (de-assimilation), but during further stages of growth and development and in high temperature conditions it can reach up to 90 % (Gharibyan, 2014, Krug, 2000).

High seedling survival rates were recorded in all net-shaded plots, where during the recovery activities fewer seedlings by about 40 % were used as compared to the variants cultivated without netting. In all cases, the same density of vegetation cover was ensured in the test plots: dried out seedlings were replaced with new ones during a week.

Regarding the phenological phases of eggplant and pepper the periods from germination to blooming and start of fruits technical maturation were estimated, the results of which are presented in Table 1. From the data in the table, it is obvious that eggplants are more sensitive to the net shading factor, as in the case of the earliest germination, the plant blooming was recorded 2 days later, compared to the blooming process recorded in the net-free variant, where the germination was 2 days later compared to that of net shading variant. In case of pepper, the plants under the net germinated a day earlier, but the blooming was recorded one day later compared to the net-free variant. According to another estimation, if the blooming of eggplants was recorded with a 4-day difference, then it was 1-2 days for pepper plants. These differences can be explained mainly by the thermal factor and the effect of direct sunlight on the plants, the high rates of which can cause stress in the eggplant and pepper crops, which accelerates the development processes.

A similar pattern was recorded between the initial periods of the fruits technical ripening, after which, until October 21, harvesting was carried out regularly, 1-2 times a week, but in August and September the harvesting frequency was twice a week. It is worth mentioning that in the net-free variant, harvesting of eggplant and pepper started 4 days earlier in comparison with those in net shading condition, making 68 and 65 days after planting, respectively.

Vegetable plants highly depend on soil fertility and they grow, develop and yield well in nutrient-rich soils. At the same time, it should be taken into account that a number of external factors, such as heat, humidity, solar radiation, etc., have a great impact on the assimilation of nutrients by plants. Since the plants moisture supply was at the same level, it is supposed that the heat factor is the main reason for some but at the same time regular differences between the plants height in all experimental variants of both crops. In all variants of net shading cultivation, the average height of plants exceeded that of plants grown in net-free conditions, thus, in case of eggplant it was 18.8 cm and in case of pepper it was only 5.3 cm. The normal vegetative growth of plants, and therefore the effective height of plants, results in many lateral branches, on which more crop rings and a great number of fruits are developed (Melikyan, 2005, Tarakanov and Mukhin, 2003).

In environmentally favorable conditions relatively larger

Table 1. Transitional periods of phenological stages for eggplant and pepper*

Crop	Cultivation conditions	Germination	Blooming	From germination to the start of fruit maturation, days	
				technical	full
Eggplant	Under net	18/05	30/06	68	-
	Without net	20/05	28/06	64	-
Pepper	Under net	21/05	02/07	65	89
	Without net	22/05	01/07	61	87

*Composed by the authors.

fruits are developed on exuberant plants, which contain sufficient amount of nutrients, and their weight does not harm the mother plant. Throughout the experiments, the average weight of eggplant and pepper fruits was measured during the entire harvest period by weighing samples taken from all experimental beds after each harvest. It is obvious that relatively larger fruits were produced in all options with net shading cultivation, which are closer to the indicators presented in the varietal characteristics. The difference amounted to 15 grams per eggplant fruit, and 7 grams per pepper fruit (Table 2).

Table 2. Biometric indicators, actual yield and marketable quality of eggplant and pepper yield*

Crops	Cultivation conditions	Average height of a plant at the beginning of harvest, cm	Average weight of a fruit, g	Harvesting duration, days	Actual yield, c/ha	Marketable groups of the yield, %	
						Class I	Class II
Eggplant	Under net	92.4	312	88	325	78	17
	Without net	73.6	297	90	280	72	22
Pepper	Under net	68.3	91	88	268	79	15
	Without net	62.7	84	91	246	82	14

*Composed by the authors.

The first harvesting of eggplant and pepper was conducted when the fruits obtained marketable form and the seeds in the fruits were not yet hardened. As to pepper, after the second decade of September, when harvesting green fruits, a certain amount of fruits was left on the plants, which ripened red and were collected at the stage of biological ripening and were counted in the total harvest amount. During the experiments, the first harvest of eggplant and pepper fruits cultivated in net-shaded conditions was carried out on July 25, and those of non-shaded option were harvested 2-3 days earlier – on July 23 and 22, respectively. The indicators of the harvesting duration are estimated, since the last harvest for all options was implemented on October 21. The total yield amount obtained as a result of periodically conducted harvesting was calculated and then sorted in the field according to two marketable groups, containerized and immediately sent for consumption. For both tested crops, a high quantity and quality yield was obtained in case of net shading options: 325 c/ha for eggplant and 268 c/ha for pepper, which were

higher than those in non-shaded options by 45 c/ha and 22 c/ha, respectively. In the yield marketable groups, the non-shaded pepper variety was an exception, where the number of first-class fruits was higher than that of the net-shaded variant by 3 %. It is believed that this difference is due to the number of fruits left for biological ripening, which were of relatively higher quality.

Conclusion

Based on the results of our studies obtained throughout vegetation period of 2022, we may conclude that the use of hail protection nets in the vegetable growing branch has an important agro-technical and economic significance. It provides the farmers an opportunity not only to protect open fields from natural disasters such as hailstorms, but also to somehow regulate the environmental conditions, particularly the heat factor and radiation, creating more effective growing conditions for crops. Based on the results of these studies, it is recommended to use field hail protection nets in open field conditions, especially in the areas of vegetable crop cultivation in the Ararat valley, which can serve as an effective technological factor to ensure possibly high-quality and rich commercial yield.

References

1. Andreyev, Yu.M. (2003). Vegetable Growing, Moscow, - p. 250 (in Russian).
2. Balashev, N.N., Zeman, G.O. (1981). – Vegetable Growing, Tashkent, - p. 368 (in Russian).
3. Dospekhov, B.A. (1985). Field Experiment Methodology, - p. 351 (in Russian).
4. Gharibyan, G. (2014). Vegetable Growing – Yerevan, - p. 160 (in Armenian).
5. Grigoryan, K.A. (1999). “Problems of Vegetable Production, Processing Economics and Marketing in RA”, Yerevan, - p. 45.
6. Krug, G. (2000). Vegetable Growing, Moscow, Kolos, - p. 576.
7. Melikyan, A.Sh. (2005). Vegetable Growing, Yerevan, - p. 503.
8. Sarukhanyan, N. (2016). Solanaceous Crops, a Guide, Yerevan, - p.42.
9. Statistical Yearbooks, 2021 www.armstat.am/am/?nid=586&year=2021.
10. Tarakanov, G.I., Mukhin, V.D. (2003). Vegetable Growing, Moscow, Kolos, - p. 478 (in Russian).
11. UNECE Standard ffv-05 - United Nations New York and Geneva, 2017.

Accepted on 07.11.2022
Reviewed on 08.11.2022



UDC 639.331.7(479.25)

Ophthalmohelminthiasis in the Water Basins of Armenia

V.V. Grigoryan, A.R. Hakobyan, O.V. Shcherbakov, L.H. Grigoryan

Armenian National Agrarian University

grigoryanvgv@mail.ru, akobian.anush@yandex.ru, oleg1vet@google.com, lianagrigoryan7878@mail.ru

ARTICLE INFO

Keywords:

ophthalmohelminthiasis,
fish,
diplostomiasis,
water basin, metacercariae

ABSTRACT

Ophthalmohelminthiasis are rather widespread in the natural and artificial water basins of Armenia.

Totally 126 fish of 7 species have been researched. Fish was taken from the pond farms of the Ararat, Armavir, Kotayk and Aragatsotn regions, as well as from the rivers and ponds of the Ararat valley, the river Hrazdan and Lake Sevan.

During the investigations 4 species of pathogens have been detected: *Diplostomum spathaceum*, *D. rutili*, *D. mergi*, and *Tylodelphys clavata*. The metacercariae of the pathogen of *Diplostomum spathaceum* have been detected in the fish of relatively well-maintained basins, while those of *D. rutili* have been detected in the fish of waterbasins contaminated with sewage waters.

Introduction

In recent decades, an exponential growth in pisciculture has been observed in Armenia. The demand for fish and fish products in the republic surpasses the current production volumes, therefore, along with existing natural basins, new artificial ponds are being operated. Currently, an objective has been set up in our republic to breed not only popular but also new fish species. Fish farming is surely considered to be the most profitable branch of agriculture; anyhow, very often various diseases become an obstacle for the development of fish breeding sector and cause considerable damage to the overall economy.

Due to the diseases, the growth and development of fish is suppressed, the reproductive function in the producing organizations is declined, while the quality of manufactured fish product doesn't meet the appropriate requirements and the percentage of fish mortality grows up (Venetikyan, 2005).

The study of parasitological situation in separate ponds of the region is not only of fundamental but also of practical significance. The knowledge in the species composition of individual fish parasites, their prevalence and quantity can be used in faunology, meteorology, and ecological parasitology.

The study on individual species of parasites living in a specific pond is rather significant for the estimation of economic damage related to fish mortality, as well as for maintaining health of population, fish-eating birds and mammals. For the mentioned categories fish are considered to be definitive, intermediate/transport, and reserve hosts of a number of parasites.

Trematodes or flatworms (Platyhelminthes: Trematoda) are singled out among the important components of fish parasitic fauna, whose larval and sexually mature forms can infect almost all the organs and tissues of all the systematic groups of fish. Trematodes can cause not only serious pathological changes in fish but also affect their marketable appearance making them unfit for human consumption: the qualitative indicators of fish carcass decline, the moisture content grows up by 3 to 5 %, while the protein and fat contents fall down by 7 to 10 % (Venetikyan, 2005). Larvae of some trematodes are also hatching in the fish eye causing blindness. The disease caused by the trematodes of the fish eye is called ophthalmohelminthiasis (Sevastyanova, 2017).

Ophthalmohelminthiasis is a widespread disease, which is caused by the metacercariae (larvae) of digenetic suckers belonging to family Diplostomidae. Metacercariae are located in the eye lens and sometimes in vitreous body causing lens opacity, while in case of severe infection it entails to blindness (Ministry of Agriculture of the Russian Federation, 1998).

The disease is found both in natural water basins, as well as in artificial ponds and reservoirs. The sexually mature forms of these trematodes parasitize in the intestines of fish-eating birds, and have not zoonotic/public health importance, whilst the infective larvae affect fish growth and development, which in its turn entails to considerable economic losses.

Diplostomiasis is a widespread parasitic disease, the causative agents of which are found in more than 125 species of Minnows and Carps (Cyprinidae, Acipenserids/sturgeon, and other fish species). The disease in fish is caused by the metacercariae of trematodes of genus *Diplostomum*. The parasites hatch in the fish eye, more often in eye lens and vitreous bodies (Shigin, 1986).

The body of metacercariae is oval with up to 0.55 mm length. At the anterior end of the parasite the mouth sucker is situated followed by pharynx and esophagus. The esophagus is divided into 2 blind-ending tubes extended up to the posterior end of the body. At the midventral part the ventral sucker is placed sequenced by Brandes' organ (Shigin, 1986).

The development cycle of the pathogen is rather complicated (Figure 1).

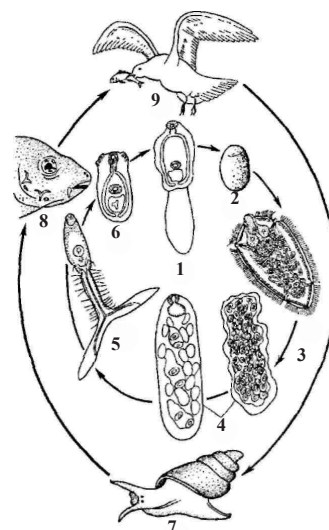

Figure 1. The developmental cycle of diplostomides: 1-Adult trematode, 2-egg, 3-miracidium, 4-sporocysts and rediae, 5-cercariae, 6-metacercariae, 7-intermediate host, 8-additional or second intermediate host, 9-definitive host (www.researchgate.net).

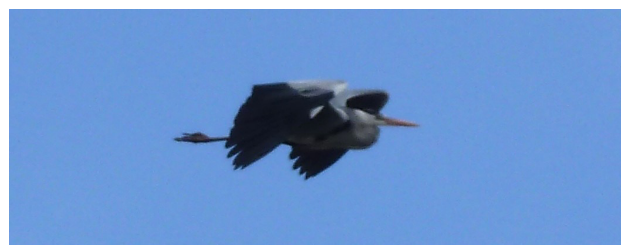

Figure 2. Grey heron (*Ardea cinerea*), a common definitive host of *Diplostomum sp.* in Armenia (www.researchgate.net).

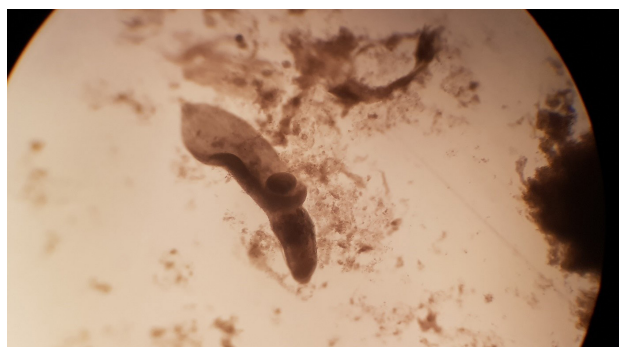

Figure 3. Adult *Diplostomum spathaceum* in grey heron's small intestine (www.researchgate.net).

In Armenia, the sexually mature pathogens are mainly detected in the intestines of gulls, herons, ducks and other fish-eating birds (Figure 2).

The intermediate hosts are various gastropod snails (Voropaeva, et al., 2008), and additional intermediate hosts are hundreds of fish species belonging to different systematic groups.

The studies on fish parasites date back to early times, but mainly individual ponds were investigated (Petukhov, 2003, Novak, 2010, Ivanov, 2012).

A number of research activities on the fish parasitic fauna have been also carried out in the natural and artificial ponds located in the territory of the Republic of Armenia (Vardanyan, et al., 1972, Voropaeva, et al., 2008, Hovhannisyan, 2008, 2009, 2010).

Materials and methods

The investigations were carried out in 2021-2022 at the Research Center for Veterinary Medicine and Veterinary Sanitary Examination of the Armenian National Agrarian University, as well as at the Laboratory of General Parasitology and Helminthology of the Scientific Center of Zoology and Hydroecology, National Academy of Sciences of the Republic of Armenia.

Totally 126 fish samples of 7 species have been researched. Fish was taken from the pond farms of the Ararat, Armavir, Kotayk and Aragatsotn regions, from the rivers and ponds of Ararat valley, as well as from the Hrazdan river and Lake Sevan.

To detect the helminths or larvae of the eyes the eyeball was taken out from the eyesocket, the vitreous body and eyelens were removed, then squeezed with the compressor or glass slides, and examined with small magnification of the microscope. The species identification of the trematodes was conducted via a special ID key (Shigin, 1986, Sudarikov, 2002).

Results and discussions

Research results are presented in the Table.

The table data show that 49 samples (39.68 %) out of the 126 investigated fish were infected with metacercariae. The pathogens were detected both in the artificial and natural pond farms and water basins.

The research results indicate that there are 4 species of pathogens in the fish eyes: *Diplostomum spathaceum* Rudolphi, 1819, *D. rutili* Razmashkin, 1969, *D. mergi*

Dubois, 1932, and *Tylodelphys clavata* von Nordmann, 1832. As a rule, the metacercariae of *D. spathaceum* (Figure 5) trematode were detected in the fish of the so called well-maintained basins, and in the undermaintained basins, like Yerevan Lake, Hrazdan River, particularly in its lower streams, the metacercariae of *D. rutili* (Figure 4) trematode were found. This is possibly related to the pollution rate of water basins. *D. rutili* find more favorable surviving conditions in the organisms of fish inhabiting in the basins contaminated with sewage waters in contrast to *D. spathaceum* metacercariae.

Table. Fish infection with diplostomiasis*

Fish species	Researched fish number	Infected fish number	Infection rate, %	Species detected
Wild Prussian carp (<i>Cyprinus carpio</i> Linnaeus, 1758)	6	3	50	<i>D. spathaceum</i>
Common carps (<i>Cyprinus carpio</i> Linnaeus, 1758)	25	8	32	<i>D. spathaceum</i>
Rainbow trout (<i>Parasalmo mykiss</i> Walbaum, 1972)	21	1	4.76	<i>D. spathaceum</i>
<i>Capoeta capoeta sevangi</i> De Filippi, 1865	12	2	16.67	<i>D. spathaceum</i>
<i>Rutilus schelkovnikovii</i> Derjavin, 1926	5	5	100	<i>D. rutili</i> , <i>D. spathaceum</i>
Sevan whitefish (<i>Coregonus lavaretus</i> Linnaeus, 1758)	22	17	63.6	<i>D. spathaceum</i> , <i>T. clavata</i>
<i>Alburnoides eichwaldii</i> De Filippi, 186	10	3	30	<i>D. rutili</i>
Crucian carp from Lake Sevan and Ararat Valley water basins (<i>Carassius auratus</i> Linnaeus, 1758)	22	9	40.9	<i>D. spathaceum</i> , <i>D. mergi</i>
Crucian carp from Yerevan Lake (<i>Carassius auratus</i> Linnaeus, 1758)	3	2	66.6	<i>D. rutili</i>
Total	126	50	39.68	

*Composed by the authors.



Figure 4. Metacercariae of *Diplostomum rutili* (www.researchgate.net).



Figure 6. Metacercaria of *Tylodelphys clavata* (www.researchgate.net).

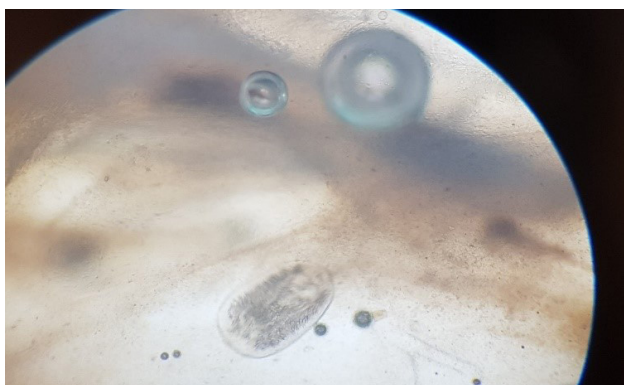

Figure 5. Metacercaria of *Diplostomum spathaceum* (www.researchgate.net).



Figure 7. Fish eye infected with *D. spathaceum* metacercariae (www.researchgate.net).

The highest infection rate with the pathogen of *D. spathaceum* is observed in Lake Sevan and it amounts to 63.6 % in the whitefish, while the pathogens of *D. rutili* (maximum 66.6 to 100 %) have been detected in the crucian carp and *Rutilus schelkovnikovi* living in the lower streams of the river Hrazdan. *D. mergi* metacercaria was detected in one crucian carp from the low stream of river Hrazdan only.

Tylodelphys clavata metacercariae (Figure 6) were registered in whitefish from Lake Sevan only.

The number of metacercariae in the eye fluctuates within 1 to 20. In 18 samples (36 % of the infected fish) both eyes were infected, while in 32 samples (64 % of the infected fish) only one eye was affected. There wasn't any regularity regarding the infection rate of left and right eyes.

The metacercariae in the eye lens cause lens opacity, and

the light doesn't penetrate into the posterior eye chamber. Due to the accumulation of calcareous particles, the lens becomes milk-colored (Figure 7). Due to the exudate afflux in the anterior chamber of the eye exophthalmia is developed. The eye lens is deformed and in the result of cornea rupture it can be displaced. Ultimately, the fish becomes blind, loses appetite, emaciation is observed. Hence, it either dies or becomes foodstuff for fish-eating birds.

Conclusion

1. Ophthalmohelminthiasis is a rather common disease occurred in the natural and artificial ponds of the Republic of Armenia; about 39.68 % of the investigated fish are infected with the mentioned disease.

2. Four pathogen species have been detected: *Diplostomum spathaceum*, *D. rutili*, *D. mergi*, and *Tylodelphys clavata*.

3. The metacercariae of *D. spathaceum* have been detected in the fish of relatively well-maintained water basins, while the metacercariae of *D. rutili* pathogen – in the fish of water basins contaminated with sewage water.

References

1. Hovhannisyan, R.L. (2008). Helminthiasis of Fish from Carp Pond Farms of the Ararat Valley // Biodiversity and Ecology of Parasites of Terrestrial and Aquatic Coenosis. Proceedings for the International Conference. Moscow, - pp. 264-266.
2. Hovhannisyan, R.L. (2009). New Species in the Helminth Fauna of Fish in Armenia // Biological Journal of Armenia. Vol. 61, - N 3, - pp. 32-37.
3. Hovhannisyan, R.L. (2010). To the Species Composition of the Helminths of the Sevan Lake Fish // Biological Journal of Armenia. Vol. 3, - N 62, - pp. 34-37.
4. Ivanov, V.M. (2012). Helminths in the Ecosystem of the Volga Delta. Volume 1. Trematodes / V.M. Ivanov, N.N. Semenova, A.P. Kalmykov - Astrakhan: State Enterprise JSC Publishing and Printing Complex "Volga", - 255 p.
5. Novak, A.I. (2010). Fish Invasions in Reservoirs with Different Ecological Conditions // Russian Journal of Parasitology, - №. 2, - pp. 6-10.
6. Petukhov, A.N. (2003). Changes in Species Diversity and Ecology of Parasitic Fish of the Gorky Reservoir: PhD for Candidate of Biological Sciences: 03.00.19 / A.N. Petukhov. - M., - 23 p.
7. Sevastyanova, Yu.Yu. (2017). Ocular Forms of Trematode Metacercariae in Fish from the Belgorod Reservoir, - 40 p.
8. Shigin, A.A. (1986). Trematodes of the USSR Fauna: Diplostomum Metacercariae. - Moscow: "Nauka", - 254 p.
9. Sudarikov, V.E. (2002). Trematode Metacercariae as Parasites of Freshwater Hydrobionts in Central Russia / V.E. Sudarikov, A.A. Shigin, Yu.V. Kurochkin. - Moscow: "Nauka" - 298 p.
10. Temporary Instruction on Measures of Control of Diplostomiasis in Freshwater Fish. Ministry of Agriculture of the Russian Federation, 1998, - 6 p.
11. Vardanyan, L.K., Mkrtchyan, Z.A. (1972). Helminth Fauna and Seasonal Dynamics of Infestation of Whitefish in Lake Sevan // Biological Journal of Armenia, - vol. 25, - N 4. - pp. 67-71.
12. Venetikyan, Sh.A. (2005). Veterinary and Sanitary Assessment of Fish with Diplostomiasis. Abstract of Thesis. Yerevan, - 17 p. (in Armenian).
13. Voropaeva, E.L., Tolstenkov, O.O. (2008). To the Study of the Parasite Fauna of Fishes of Lake Sevan // Materials of the IV All-Russian Congress on the Parasitological Society at the Russian Academy of Sciences. Volume 1. St.-Petersburg, - pp. 138-141.

Accepted on 31.08.2022

Reviewed on 11.10.2022



UDC 577.2(479.25)

Bacterial Communities of Bartonella-Positive Fleas in Gut Microbiota of Armenian Populations

N.H. Harutyunyan, A.M. Manvelyan, M.H. Balayan, A.Z. Pepoyan

Armenian National Agrarian University

natalya.harutyunyan@list.ru, a_manvelyan@list.ru, marine.balayan@gmail.com, aepoyan@gmail.com

ARTICLE INFO

Keywords:

Bartonella,
zoonosis,
Familial Mediterranean Fever,
gut microflora,
Bartonella-positive fleas

ABSTRACT

Bartonella spp. are known as causative agents of zoonosis. The information on the reservoirs of *Bartonella spp.* mammals /fleas/ ticks, is limited in Armenia. The aim of this study was, on the basis of the available PhyloChip™ data from the previous investigations, to study bacterial communities in healthy and patients with Familial Mediterranean Fever of the Armenian population that have common gene sequences with *Bartonella*-positive fleas.

The preliminary results on PhyloChip™ analysis revealed operational taxonomic units of several gut bacterial communities in healthy people and patients with FMF in the Armenian population sharing common gene-sequences with the *Bartonella*- positive fleas.

Introduction

Bartonella spp. bacteria can be observed around the globe and are the causative agents of emerging and reemerging human diseases. Bacteria of the genus *Bartonella* are fastidious, gradually-growing gram-negative aerobic rods. They parasitize erythrocytes and endothelial cells of a wide range of mammals and are generally host specific at different taxonomical levels (Bai, et al., 2013, Breitschwerdt, 2017, Kosoy, 2018, Ying, et al., 2002) (Table 1).

Rapid growth of populations, particularly in areas with weak health systems, urbanization, globalization and inequalities within cities, climate change, and the changing nature of pathogen transmission between

human and animal populations are an important cause of zoonosis. *Bartonella* species, widely known as causative agents of zoonosis, involve a broad spectrum of clinical syndromes from self-limited cat-scratch disease (CSD) to potentially fatal diseases, such as endocarditis (Chomel, 2009) mild lymphadenopathy and fever (Anderson, et al., 1997, Kosoy, et al., 2010, 2018, Chomel, et al., 2004), and their DNA can be found in multiple vectors (Cheslock and Embers, 2019).

Pets (Chomel, et al., 2006), especially cats (Razgūnait, et al., 2021), are large reservoirs for human infection (Angelakis, et al., 2014, Iannino, et al., 2018). The disease is widely transmitted to cats (Petříková, et al., 2021) and

rodents (Gutiérrez, et al., 2015) by fleas. It has also been discovered in a wide range of mammals, including humans, cats, dogs, rabbits, rodents, horses, cattle, and other wildlife (Chomel, et al., 2009, Iannino, et al., 2018, Breitschwerdt, et al., 2017).

Materials and methods

Historically, the most common causative agents for human cases of bartonellosis have been *Bartonella bacilliformis*, *Bartonella quintana*, and *Bartonella henselae* (Angelakis, et al., 2014, Breitschwerdt, et al., 2019). These infections are characterized by a prolonged intraerythrocytic bacteremia, fever, headache, and malaise to more severe

symptoms such as hallucinations (Ben-Tekaya, et al., 2013, Kalogeropoulos, et al., 2019).

According to retrieved PubMed information, several cases of bartonellosis have been reported in Caucasus (Malania, et al., 2016), but the information on the reservoirs of *Bartonella spp.*: mammals/fleas/ticks, is limited in Armenia. The third generation, culture-independent, high-density DNA microarray (PhyloChip™; Affymetrix, Santa Clara, CA, USA) (Harutyunyan, et al., 2013, 2014a, 2014b, Pepoyan, et al., 2014a, 2014b, 2015a, 2015b, 2018, 2019, 2021, Piceno, et al., 2013) was used during our previous investigations on gut microbiota of Familial Mediterranean Fever (FMF) patients. The aim of this study was, on the basis of the available PhyloChip™ data from the previous investigations, to study bacterial communities in healthy people and patients with FMF in the Armenian population that have common gene sequences with *Bartonella*-positive fleas.

Table 1. The known *Bartonella* species, their hosts and their vectors*

Bartonella Species	Host (s)	Vector(s)
<i>B. henselae</i>	Cat, human, dogs, horses	Fleas, lice, ticks, spiders
<i>B. quintana</i>	Humans, macaques, cats, dogs	Human body lice, fleas, bed bugs
<i>B. bacilliformis</i>	Humans	Sandflies, fleas
<i>B. koehlerae</i>	Cats, dogs, humans	Fleas
<i>B. vinsonii ssp. berkhoffi</i>	Dogs, horses, foxes, humans	Fleas, ticks
<i>B. bovis</i>	Cattle, cats, dogs, human	Biting flies, ticks
<i>B. clarridgeiae</i>	Cats, dogs	Fleas, ticks
<i>B. rattimassiliensis</i>	Rats	Fleas
<i>B. tamiae</i>	Rats, humans	Mites
<i>B. tribocorum</i>	Rats	Fleas
<i>B. rousetii</i>	Bats	Bat flies
<i>B. schoenbuchensis</i>	Cattle	Biting flies, ticks
<i>B. chomelii</i>	Cattle	Biting flies, ticks
<i>B. doshiae</i>	Rats, humans	Fleas
<i>B. grahamii</i>	Mice, humans	Fleas
<i>B. birtlesii</i>	Mice	Fleas
<i>B. mayotimonensis</i>	Bats, humans	Bat flies, fleas, ticks
<i>B. elizabethae</i>	Rats, humans, dogs	Fleas
<i>B. washoensis</i>	Dogs, humans	Fleas, ticks
<i>B. rochalimae</i>	Dogs, humans	Fleas, ticks
<i>B. vinsonii ssp. arupensis</i>	Dogs, humans	Fleas, ticks
<i>B. melophagi</i>	Sheep, humans	Sheep keds
<i>B. alsatica</i>	Rabbits, humans	Fleas, ticks

*The table has been adapted from Breitschwerdt E.B., 2017, Chapter 5.2.

Results and discussions

Forty healthy and forty FMF volunteers participated in investigations. A detailed information of these investigations is available at Pepoyan et al. (Pepoyan, et al., 2018, www.ncbi.nlm.nih.gov).

Also, the literature data were collected from PubMed (1997-2021, main keywords: *Bartonella spp* and Caucasus).

Bacterial communities of *Bartonella*-positive fleas in gut microbiota of Armenian healthy and FMF patients' populations are presented in Table 2. The pilot PhyloChip™ analysis revealed operational taxonomic units (OTU) of several gut bacterial communities in healthy people and patients with FMF in the Armenian population sharing common gene-sequences with the *Bartonella*-positive fleas. According to Table 2, *Proteobacteria*, *Fusobacteria* and *Firmicutes* were the main bacterial phyla sharing common gene-sequences with the *Bartonella*-positive fleas. There were no statistically significant differences in the hybridization scores of these bacteria from the healthy and diseased groups.

The investigations on the seroprevalence against *B. henselae* and *B. quintana* of 536 people from the Eastern Slovakia, with no data on the human bartonellosis cases as it was in Armenia, revealed that 23.5 % of the people demonstrated positivity for anti-*B. henselae* antibodies and 24.8 % against *B. quintana* (Petříková, et al., 2021). Statistically significant, but clinically irrelevant differences in uric acid levels and serum creatinine were described between *B. henselae* seropositive and seronegative groups (Petříková, et al., 2021).

Table 2. Bacterial communities of *Bartonella*-positive fleas in gut microbiota of Armenian healthy and FMF patients' populations*

Bacterial genus	Healthy Men volunteers (N=40)	Male FMF volunteers (N=40) (hybridization score)
<i>Haemophilus</i>	598±105 ^a	432 ± 125 ^a P>0.05
<i>Aquabacterium</i>	4137±760 ^a	5005 ± 1351 ^a P>0.05
<i>Aquabacterium</i>	1408±507 ^a	1970 ± 102 ^a P>0.05
<i>Aquabacterium</i>	3070±885 ^a	3673 ± 189 ^a P>0.05
<i>Faecalibacterium</i>	9642±257 ^a	9268 ± 251 ^a P>0.05
<i>Oscillospira</i>	1930±922 ^a	2623 ± 119 ^a P>0.05

N – Number of volunteers
a-hybridization score
P < 0.05 is statistically significant

*Composed by the authors.

Conclusion

Thus, future investigations on reservoirs of *Bartonella* spp. in mammals/fleas/ticks in Armenia, as well as future immunologic and molecular biological investigations on transmission of *Bartonella* spp. are required.

References

- Anderson, B.E., Neuman, M.A. (1997). *Bartonella* spp. as Emerging Human Pathogens. // Clin Microbiol Rev. - V.10, - pp. 203-219. <https://doi.org/10.1128/cmr.10.2.203>.
- Angelakis, E., Raoult, D. (2014). Pathogenicity and Treatment of *bartonella* Infections. // Int. J. Antimicrob. Agents -V.44, -pp. 16-2. <https://doi.org/10.1016/j.ijantimicag.2014.04.006>.
- Bai, Y., Malania, L., Castillo, D.A., Moran, D., Boonmar, S., Chanlun, A., Suksawat, F., Maruyama, S., Knobel, D., Kosoy, M. (2013). Global Distribution of *Bartonella* Infections in Domestic Bovine and Characterization of *Bartonella bovis* Strains Using Multi-Locus Sequence Typing // PLoS One -V. 8, - pp. e80894. <https://doi.org/10.1371/journal.pone.0080894>.
- Ben-Tekaya, H., Gorvel, J.P., Dehio, C. (2013). *Bartonella* and *Brucella*– Weapons and Strategies for Stealth Attack // Cold Spring Harb. Perspect. Med.-V. 3, -pp. a010231. <https://doi.org/10.1101%2Fcsphperspect.a010231>.
- Breitschwerdt, E.B. (2017). Bartonellosis, One Health and All Creatures Great and Small. // Vet. Dermatol. -V. 8, - Chapter 5.2, - pp. 111-121. <https://doi.org/10.1002/9781119278368.ch5.2>.
- Breitschwerdt, E.B., Greenberg, R., Maggi, R.G., Mozayani, B.R., Lewis, A., Bradley, J.M. (2019). *Bartonella henselae* Bloodstream Infection in a Boy with Pediatric Acute-Onset Neuropsychiatric Syndrome. // J. Cent. Nervous Syst. Dis. - V. 11 <https://doi.org/10.1177/1179573519832014>.
- Cheslock, M.A., Embers, M.E. (2019). Human Bartonellosis: An Underappreciated Public Health Problem? // Trop. Med. Infect. Dis. - V. 4, - p. 69. <https://doi.org/10.3390/tropicalmed4020069>.
- Chomel, B.B., Boulouis, H.J., Breitschwerdt, E.B. (2004). Cat Scratch Disease and Other Zoonotic *Bartonella* Infections. // J Am Vet Med Assoc. – V. 224, - pp. 1270–1279. <https://doi.org/10.2460/javma.2004.224.1270>.
- Chomel, B.B., Boulouis, H.J., Maruyama, S., Breitschwerdt, E.B. (2006). *Bartonella* spp. in Pets and Effect on Human Health // Emerg Infect Dis. –V. 12, - pp. 389-394. <https://doi.org/10.3201/eid1203.050931>.
- Chomel, B.B., Kasten, R.W., Williams, C., Wey, A.C., Henn, J.B., Maggi, R., Carrasco, S., Mazet, J., Boulouis, H.J., Maillard, R. (2009). *Bartonella* endocarditis: A Pathology Shared by Animal Reservoirs and Patients. // Ann. N. Y. Acad. Sci. –V. 1166, - pp. 120–126. <https://doi.org/10.1111/j.1749-6632.2009.04523.x>.
- Gutiérrez, R., Krasnov, B., Morick, D., Gottlieb, Y., Khokhlova, I.S., Harrus, S. (2015). *Bartonella* Infection in Rodents and their Flea Ectoparasites: an Overview // Vector Borne Zoonotic Dis. – V. 15, - pp. 27-39. <https://doi.org/10.1089/vbz.2014.1606>.
- Harutyunyan, N., Balayan, M., Tsaturyan, V., Manvelyan, A., Pepoyan, A., Piceno, Y., Torok, T. (2014a). Effects of Probiotics on the Gut Microbiota Composition of Armenian Populations

- with Familial Mediterranean Fever Disease. International Conference “Trends in Microbiology and Microbial Biotechnology”. October 5-8, Yerevan, YSU press, - p. 3, isbn 978-5-8084-1895-0 https://www.researchgate.net/publication/267094941_EFFECTS_OF_PROBIOTICS_ON_THE_GUT_MICROBIOTA_COMPOSITION_OF_ARMENIAN_POPULATIONS_WITH_FAMILIAL_MEDITERRANEAN_FEVER_DISEASE .
13. Harutyunyan, N.A., Manvelyan, A.M., Balayan, M.H., Mirzabekyan, S.S., Malkhasyan, L.M., Pepoyan, A., Piceno, Y., Torok, T. (2013). *PhiloChip*TM Microarray Comparison of Sampling Methods Used for Gut Microbiota Investigation. “The 2nd International Scientific Conference of Young Researches on Biotechnology, General and Applied Microbiology, Chemistry, Biochemistry, Molecular Biology and Genetics, Environmental Protection”. October 1-4, Yerevan, Book of Abstracts, -pp. 83-84.
 14. Harutyunyan, N., Tsaturyan, V., Manvelyan, A., Balayan, M., Pepoyan, A., Piceno, Y., Torok, T. (2014b). Comparative Analysis of Bacterial Enumerations in Fecal Samples of Patients with Familial Mediterranean Fever Disease by Culture-Based and *PhiloChip* Techniques. “3-rd International Conference on Clinical Microbiology and Microbial Genomics”. September 24-26, Valencia, Spain, -p. 57.
 15. Iannino, F., Salucci, S., Di Provvido, A., Paolini, A., Ruggieri, E. (2018). *Bartonella* Infections in Humans, Dogs and Cats. // *Vet. Ital.* –V. 54, -pp. 63–72. <https://doi.org/10.12834/vetit.398.1883.2>.
 16. Kalogeropoulos, D., Asproudis, I., Stefanidou, M., Moschos, M.M., Mentis, A., Malamos, K., Kalogeropoulos, C. (2019). *Bartonella henselae*- and *quintana*-associated uveitis: A Case Series and Approach of a Potentially Severe Disease with a Broad Spectrum of Ocular Manifestations. // *Int. Ophthalmol.* - V. 39, - pp. 2505-2515. <https://doi.org/10.1007/s10792-019-01096-7>.
 17. Kosoy, M., Bai, Y., Sheff, K., Morway, C., Baggett, H., Maloney, S.A., Boonmar, S., Bhengsi, S., Dowell, S.F., Sitdhirasdr, A., Lerthussanee, K., Richardson, J., Peruski, L.F. (2010). Identification of *Bartonella* Infections in Febrile Human Patients from Thailand and their Potential Animal Reservoirs. // *Am J Trop Med Hyg.* – V. 82, - pp. 1140–1145.
 18. Kosoy, M., Mckee, C., Albayrak, L., Fofanov, Y. (2018). Genotyping of *Bartonella* Bacteria and their Animal Hosts: Current Status and Perspectives. // *Parasitology.* - V. 145, - pp. 543-562. <https://doi.org/10.1017/s0031182017001263>.
 19. Kosoy, M., Murray, M., Gilmore, R.D., Jr., Bai, Y., Gage, K.L. (2003). *Bartonella* Strains from Ground Squirrels are Identical to *Bartonella washoensis* Isolated from a Human Patient. // *J Clin Microbiol.* –V. 41, - pp. 645–650. <https://doi.org/10.1128/JCM.41.2.645-650.2003>.
 20. Malania, L., Bai, Y., Osikowicz, L.M., Tsertsvadze, N., Katsitadze, G., Imnadze, P., Kosoy, M. (2016). Prevalence and Diversity of *Bartonella* Species in Rodents from Georgia (Caucasus). - V. 95, - pp. 466–471. <https://doi.org/10.4269/ajtmh.16-0041>.
 21. Piceno, Y.M., Harutyunyan, N., Balayan, M., Tsaturyan, V., Manvelyan, A., Pepoyan, A., Torok, T. (2013). Effects of Probiotics on the Gut Microbiota of Armenian Populations with Familial Mediterranean Fever Using *PhiloChip* and Culture-based Analyses. “International Scientific Conference on Probiotics and Prebiotics”. June 11 – 13, Kosice, Slovakia, Book of Abstracts, - pp. 37-38. https://researchgate.net/publication/261873152_Effects_of_probiotics_on_the_gut_microbiota_of_Armenian_populations_with_Familial_Mediterranean_Fever_using_PhyloChip_and_culture-based_analyses.
 22. Pepoyan, A., Balayan, M., Manvelyan, A., Galstyan, L. (2018). Probiotic *Lactobacillus acidophilus* Strain INMIA 9602 Er 317/402 Administration Reduces the Numbers of *Candida Albicans* and Abundance of Enterobacteria in the Gut Microbiota of Familial Mediterranean Fever Patients. // *Frontiers in Immunology.* – V. 9. <https://doi.org/10.3389/fimmu.2018.01426>.
 23. Pepoyan, A.Z., Balayan, M.A., Harutyunyan, N.A., Grigoryan, A.G., Tsaturyan, V.V., Manvelyan, A.M., Dilanyan, E., Pitseno, I., Torok, T. (2015a). Antibiotic Resistance of *Escherichia Coli* of the Intestinal Microbiota in Patients with Familial Mediterranean Fever. // *Clin Med (Mosk).* – V. 93, - pp. 37-39. (in Russian) https://researchgate.net/publication/283638301_Antibiotikorezistentnost_Escherichia_coli_kisečnoj_mikrobioty_u_bolnyh_šejnejoj_sredizemnomorskoj_lihoradkoj.
 24. Pepoyan, A., Balayan, M., Harutyunyan, N., Manvelyan, A., Malkhasyan, L., Mirzabekyan, S., Isajanyan, M. (2014a). Placebo Effect in Familial Mediterranean Disease. “5th ASM Conference on Beneficial Microbes”. September 27 – 30, Washington, DC, - pp. 87. <https://researchgate.net/>

[publication/267094739 PLACEBO EFFECT IN FAMILIAL MEDITERRANEAN FEVER DISEASE.](#)

25. Pepoyan, A., Harutyunyan, N., Grigorian, A., Tsaturyan, V., Manvelyan, A., Dilanyan, E., Balayan, M., Torok, T. (2015b). The Certain Clinical Characteristics of Blood in Patients with Familial Mediterranean Fever of Armenian Population. *Klinicheskaia Laboratornaia Diagnostika* // - V. 60, - pp. 46-7. (in Russian) https://researchgate.net/publication/349075309_scopuspng.
26. Pepoyan, A., Harutyunyan, N., Pepoyan, E., Tsaturyan, V., Torok, T. (2019). Relationship between the Numbers of *Candida albicans* and Abundance of *Helicobacter spp.* in the Gut Microbiota of Familial Mediterranean Fever Patients. // *Helicobacter*. - V. 24(S1), - pp. e12647 (70). <https://doi.org/10.1111/hel.12647>.
27. Pepoyan, A., Harutyunyan, N., Tsaturyan, V. (2014b). Comparative Analysis of Bacterial Enumerations in Fecal Samples of Patients with Familial Mediterranean Fever Disease by Culture-Based and Phylochip Techniques. *Clin Microbiol.* – V. 3, - p. 57.
28. Pepoyan, A.Z., Pepoyan, E.S., Galstyan, L., Harutyunyan, N.A., Tsaturyan, V.V., Torok, T., Ermakov, A.M, Popov, I.V., Weeks, R., Chikindas, M.L. (2021). The Effect of Immunobiotic/ Psychobiotic *Lactobacillus acidophilus* Strain INMIA 9602 Er 317/402 Narine on Gut *Prevotella* in Familial Mediterranean Fever: Gender-Associated Effects. // *Probiotics & Antimicro. Prot.* – V. 13, - pp. 1306-1315. <https://doi.org/10.1007/s12602-021-09779-3>.
29. Petriková, K., Halánová, M., Babinská, I. (2021). Seroprevalence of *Bartonella henselae* and *Bartonella quintana* Infection and Impact of Related Risk Factors in People from Eastern Slovakia // *Pathogens*. - V. 10, - pp. 1261. Published 2021 Sep 29. <https://doi.org/10.3390/pathogens10101261>.
30. Razgūnaitė, M., Lipatova, I., Paulauskas, A., Karvelienė, B., Riškevičienė, V., Radzijeuskaja, J. (2021). *Bartonella* Infections in Cats and Cat Fleas in Lithuania. // *Pathogens*. – V. 10, - pp. 1209. <https://doi.org/10.3390/pathogens10091209>.
31. Ying, B., Kosoy, M.Y., Maupin, G.O., Tsuchiya, K.R., Gage, K.L. (2002). Genetic and Ecologic Characteristics of *Bartonella* Communities in Rodents in Southern China. // *Am J Trop Med Hyg.* – V. 66, -pp.622–627. <https://doi.org/10.4269/ajtmh.2002.66.622>.

Accepted on 07.11.2022

Reviewed on 13.11.2022



UDC 637.1:579:[619:618.19-002]

Some Biological Features of *Staphylococci* Isolated from Milk of Cows with Mastitis

A.R. Mkrtchyan, V.V. Grigoryan, H.T. Tadevosyan, L.H. Grigoryan

Armenian National Agrarian University

artur.veterinar@rambler.ru, grigoryanvgv@mail.ru, herminetadevosyan1977@mail.ru, lianagrigoryan7878@mail.ru

ARTICLE INFO

Keywords:

staphylococcus,
cow,
mastitis,
antibiotic,
treatment

ABSTRACT

White *staphylococcus spp.* is the common name for *staphylococci* that do not form a golden pigment. It causes and complicates the course of many inflammatory processes in various organs and tissues of humans and animals. In particular, in dairy cattle breeding, white staphylococcus is the main cause of serous and serous-catarrhal mastitis. Low efficiency in the treatment of staphylococcal mastitis is due to the resistance of the pathogen to antibiotics. Accordingly, the use of chemotherapeutic drugs for mastitis without prior determination of the sensitivity of isolated strains of pathogenic microorganisms to antibiotics leads to double economic damage.

Introduction

Being conditionally pathogenic microorganisms, *staphylococci* are constantly found on the outer integuments and mucous membranes of animals. The reasons, contributing to the weakening of the immune system of animals, create favorable conditions for the active reproduction of *staphylococci*, complicating the course of the underlying disease. With mastitis, as with any pathological processes accompanied by inflammation, *staphylococci* play a key role in the pathogenesis of the disease, which must be taken into account when choosing therapy methods.

According to the International Dairy Federation, mastitis is registered annually in 25 % of cows in dairy farms around the world, and according to some researchers, this figure reaches 50 %, with 97 % of cases being subclinical mastitis (Altukhov and Afanasyev, 1990). According to American researchers, up to 51 % of cows with clinical forms of mastitis are detected annually in dairy farms in the USA, the treatment of which is not always effective: up to 25% of animals get sick again. Economic damage in the country annually reaches \$ 2 billion, which is equivalent to the loss of 11 % of the total volume of milk sold (Hogeveen, et al., 2019).

The non-infectious mastitis is mainly caused by the penetration of conditionally pathogenic microorganisms into the mammary gland, namely *Staphylococcus* – *Staphylococcus albus*, which includes *staphylococci* that do not form golden pigment (*Staphylococcus epidermidis*, *Staphylococcus saprophyticus*) and is widespread in nature characterized by relative resistance to physical and chemical environmental factors and antibacterial drugs (Mkrтчyan, et al., 2020, Steven, et al., 2015). White staphylococcus is found on the external integuments of animals, on the clothes and hands of service personnel, in dairy dishes and milking equipment, in litter, manure, feed and farm air and can penetrate into the mammary gland both through the nipple canal and through damage to the udder skin; therefore, prevention of mastitis is based on compliance with veterinary and sanitary requirements when milking cows (Veterinary and sanitary rules for dairy farms, 2011). According to numerous studies, a wet udder toilet before milking reduces the amount of conditionally pathogenic microflora in milk by up to 94 % (Pankratov, 1971, Isachenko, 1987).

Low therapeutic efficacy in the treatment of mastitis and frequent relapses are due to the resistance of white staphylococcus strains to certain antibiotics, therefore, the success of therapy largely depends on the preliminary determination of the sensitivity of isolated staphylococcus strains to them and the correct choice of antibacterial agents (Mkrтчyan, et al., 2021, Marami, et al., 2012).

The purpose of our research was to identify the specific composition of *staphylococci* in serous and serous-catarrhal mastitis of cows kept in some farms of the Kotayk region of Armenia and to determine the sensitivity of isolated strains of microorganisms to antibiotics, which would allow us to offer more effective therapy methods and prevention of this pathology.

Materials and methods

The first portions of milk from the contents of the nipple canal of cows with clinical signs of serous and serous-catarrhal mastitis served as research material. Milk samples were placed in sterile test tubes, which, after labeling, were delivered to the laboratory of the Department of Epizootology and Parasitology of the Armenian National Agrarian University. The test material was diluted with sterile saline solution in a ratio of 1:10 and 0.5 ml was sown on petri dishes with mannitol salt agar (Chapman Medium USP, Eur.Pharm), which is a selective nutrient medium for *staphylococci*. Petri dishes with a nutrient

medium after sowing were kept in a thermostat at 370 °C for 24 hours. The obtained colonies were counted by visual counting, the number of microorganisms in 1 ml of the studied material was calculated using the following formula:

$$M = N:m * C,$$

where M is the number of microorganisms in 1 ml (g) of the studied material, N is the degree of dilution of the material, m is the amount of seed (ml), C is the arithmetic mean number of colonies grown on the nutrient medium.

10 cows with signs of serous and serous-catarrhal mastitis were under observation, out of which 5 animals belonged to a private farm in the community of Nor Artamed in the Kotayk region of the Republic of Armenia, and 5 more animals belonged to the educational and experimental farm of the Armenian National Agrarian University in the community of Balahovit situated at the same region of the republic. The diagnosis of serous and serous-catarrhal mastitis was made on the basis of anamnesis and clinical signs during the examination of sick animals. The sensitivity of *staphylococci* obtained on the nutrient medium to antibiotics was determined by the disc-diffusion method (Mkrтчyan and Simonyan, 2020).

Results and discussions

As a result of the conducted studies, it was revealed that out of milk samples obtained from cows with serous and serous-catarrhal mastitis, colonies of white staphylococcus mainly grow on mannitol salt agar in the form of separate convex rounded disks with smooth edges or a solid white plaque with a smooth matte surface (Figure 1). Microscopy of smears prepared from the obtained colonies and stained by the Gram method reveals random clusters of spherical bacteria of purple color, resembling bunches of grapes (Pankratov, 1971). At the same time, as can be seen from Table 1, the number of colonies of *staphylococci* isolated on a selective nutrient medium, as well as the number of *staphylococci* in 1 ml milk obtained from cows with mastitis prevails in milk samples obtained from cows with mastitis belonging to a private farm in the community of Nor Artamet. As the data of Table 1 show, the relatively low content of bacteria in milk samples obtained from cows belonging to the educational and experimental farm of the Armenian National Agrarian University is obviously due to a higher level of compliance with veterinary and sanitary rules when keeping animals compared to private farming in the community of Nor Artamet.

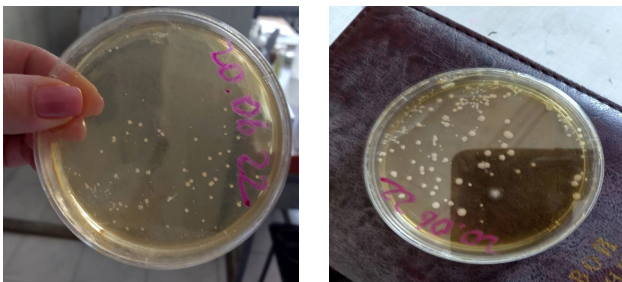

Figure 1. Colonies of *Staphylococcus albus* on mannitol salt agar.

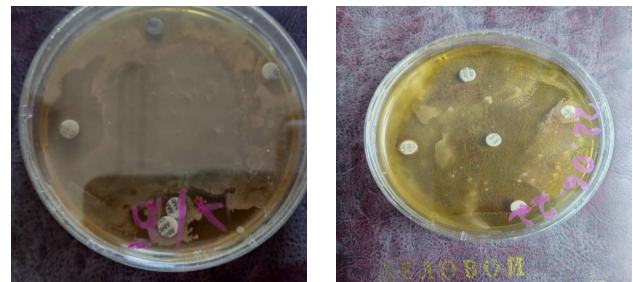

Figure 2. Determination of the sensitivity of *Staphylococcus albus* strains to antibiotics by the disc diffusion method.

Table 1. Results of bacteriological examination of milk samples from cows with mastitis*

Average number of staphylococcal colonies on mannitol salt agar		Number of staphylococci in 1 ml of milk	
Private farm in the community of Nor Artamet	Educational and experimental farm in Balahovit	Private farm in the community of Nor Artamet	Educational and experimental farm in Balahovit
46	19	920	380

Table 2. Sensitivity of *Staphylococcus albus* strains isolated from cows with mastitis to antibiotics*

Name of antibiotics	Colony growth delay zone (mm)	
	Private farm in the community of Nor Artamet	Educational and experimental farm in Balahovit
Cephasolin	0.5	2.0
Eritromicin	2.5	2.8
Levomicetin	1.0	2.0
Ampicillin	0.2	0.2
Streptomycin	0.1	0
Tetracilin	2.0	2.0

*Composed by the authors.

When determining the sensitivity of isolated staphylococcal strains to antibiotics by the disc diffusion method, it was revealed that staphylococcal strains isolated from milk samples from cows bred in the community of Nor Artamet are most sensitive to tetracycline and levomicetin (Figure 2) while staphylococcus strains isolated from milk samples of the cows kept at the experimental farm in the community of Balahovit are sensitive almost to all tested antibiotics except streptomycin. Data on the resistance

of isolated strains of *staphylococci* are given in Table 2.

The results obtained are consistent with the data of our previous studies, where almost similar sensitivity to antibiotics was observed in strains of staphylococcus isolated from the intestinal contents of dogs with gastroenteritis, as well as from the contents of the external auditory canal of dogs and cats with otodectosis (Mkrtchyan, et al., 2020, Mkrtchyan, et al., 2021).

Conclusion

Based on the results of the studies obtained, the following conclusions can be drawn:

1. In cows with serous and serous-catarrhal mastitis, the course of the disease is complicated by secondary staphylococcal infection.
2. There is a positive correlation between the degree of compliance with veterinary and sanitary rules on a dairy farm and the amount of contamination of milk with *staphylococci*.
3. Determination of antibiotic sensitivity isolated from milk samples of staphylococcus cows with mastitis will allow to achieve greater therapeutic effectiveness from chemotherapy drugs used for therapeutic purposes.

References

1. Altukhov, N.M., Afanasyev, V.I. (1990). A Short Reference of a Veterinarian. Moscow, - pp. 460-461.
2. Hogeveen, H., Steeneveld, W., Wolf, C.A. (2019). Production Diseases Reduce the Efficiency of Dairy Production. A Review of the Results, Methods and Approaches Regarding the Economics of Mastitis. Annual Review of Resource Economics. 11:289-312. <https://doi.org/10.1146/annurev-resource-100518-093954>.
3. Isachenko, L.S. (1987). An Amateur Breeder's Calendar. Moscow, - pp. 84-86.
4. Marami, L.M., Berhanu, G., Tekle, M., Agga, G.E., Bevene, T.J., Tufa, T.B., Bevi, A.F., Edao, B.M. (2012). Antimicrobial Resistance of *Staphylococci* at Animal Human Interface in Smallholders and Dairy Farms in Central Oromia, Ethiopia. Infection and Drug Resistance. - V. 15, - pp. 3767-3777.
5. Mkrtchyan, A.R., Naghashyan, H.Z., Mkrtchyan, V.K. (2020). Secondary Staphylococcal Infection in Viral and Non-Infection Gastroenteritis in Dogs. "Agriscience and Technology" Scientific Journal, 1/69, - pp. 104-107.
6. Mkrtchyan, A.R., Naghashyan, H.Z., Shcherbakov, O.V. (2021). Study of Opportunistic Pathogenic Microflora in Otodectosis of Small Domestic Animals. "Agriscience and Technology" Scientific Journal, 2/74, - pp. 174-177. <https://doi.org/10.52276/25792822-2021.2-178>.
7. Mkrtchyan, A.R., Simonyan, J.T. (2020). Microbiological Contamination of Eggs in the Shopping Centers of Nor Nork Administrative District in Yerevan. "Agriscience and Technology" Scientific Journal, 4/72, - pp. 66-68.
8. Pankratov, A.Y. (1971). Microbiology. Moscow, - pp. 222-238.
9. Steven, Y.C. Tong, Joshua, S. Davis, Emily Eichenberger, Thomas, L. Holland and Vance, G. Fowler (2015). Staphylococcus Aureus Infections: Epidemiology, Pathophysiology, Clinical Manifestations, and Management. Clin Microbiol Rev. - V. 28(3), - pp. 603-661.
10. Veterinary and Sanitary Rules for Dairy Farms, Organizations Engaged in Milk Production Activities on the Territory of the Member States of the Customs Union. Draft, Chapter 6. Customs Union 2011, - pp. 15-16.

Accepted on 18.07.2022

Reviewed on 02.11.2022



UDC 619:616.98:579.841.93(479.25)

Study of Swine Brucellosis Infection Rate in the Avan Community of Aragatsotn Region

M.A. Sargsyan, H.S. Balasanyan, G.R. Tovmasyan

Armenian National Agrarian University

mariam.sargsyan.1960@mail.ru, nanar.balasanyan.s@gmail.com, gohartovmasyan74@mail.ru

ARTICLE INFO

Keywords:

swine,
brucellosis,
serological reaction,
study,
endemia

ABSTRACT

Investigations on the swine brucellosis has been conducted for the first time within 2021-2022 throughout the recent 60 years.

Probably, the infection carrier small and large cattle have become the cause of brucellosis infection. Joint housing and zoohygienic conditions, as well as the remnants of infected dairy products have served as predisposing factors for morbidity.

Rose-Bengal test and agglutination reaction were used to detect antibodies in blood serum. As a result of epidemiological analysis, the indicators of morbidity and insecurity rates have amounted to 0.0025 (0.25 %), 0.0075 (0.75 %), respectively, while the economic damage has made AMD 1 mln 310 thousand.

Introduction

The first information about the disease of brucellosis was reported by Hippocrates, whereas the English physician Bruce first introduced the characteristic traits of brucella (Grigoryan, 2002, Vardanyan, et al., 2017).

Malta (Mediterranean) fever was known to humanity still 500 years BC, but there hasn't been any effective measure identified yet for combating and preventing it.

According to the data of International Epidemiological Office, numerous countries, thousands of livestock farms and settlements are recognized as vulnerable towards brucellosis (Bessarabov, et al., 2007, Balabanova and Kudryashov, 2019).

It is known that brucellosis is a zoonotic endemic infectious and allergic disease with chronicity characterized by miscarriages, retained placenta, abscesses, endometritis and disorders of the reproductive function of animals. It is noteworthy that the causative agents of brucellosis are intracellular pathogenic bacteria, they propagate and persist in the host's phagocytic cells infecting the system of mononuclear phagocytes (lymph nodes, kidney, spleen and bone marrow) and monocytic cells (Kudryashova and Svyatkovskovo, 2007).

There are more than 6 types of brucella – biospecies: Br. Melitensis (3 biovars), Br. abortus (7 biovars), Br. Suis (5 biovars), Br. Ovis, Br. canis, Br. neotomae and marine mammals: Br. pinnipedialis, Br. Ceti, B. Microti

(3 biovars), which can be transmitted from one animal species to another one (Kolychev and Gosmanov, 2006, Michiel, et al., 2018). Among the abovementioned species *Br. Melitensis*, *Br. abortus* and *Br. Suis* are specifically positioned in the list of hazardous infectious diseases posing threat to human life (Dimov and Arakelyan, 2008). The infection risk degree in humans depends on the pathogen virulence of *Br. melitensis*, *Br. abortus*, *Br. Suis* strains, which cause physical and mental disorders (Vershilva, 1961, Deghdzunyan and Hambardzumyan, 1990).

Over the past 20 years, swine brucellosis has become widespread in the developed pig farms of the Russian Federation (Volgograd, Voronezh, Rostov), as well as Australia, North and South America, New Zealand and other countries (Iskandarov, 2011), causing huge economic losses.

Porcine brucelli are also intracellular and sometimes extracellular pathogens that propagate in reticuloendothelial cells, causing cytopathological changes. According to pathogenicity, aggressiveness, immunological reconstructions, they are morphologically similar to the above-mentioned *Brucella* species. *Br. Suis* pathogens enter the body of animals through alimentary, mucosal, genitourinary, impaired skin integrity, and sometimes respiratory channels (Balabanova and Kudryashov, 2019).

Pigs diseased with brucellosis are characterized by limb paresis, abscesses, mummified and underdeveloped fetuses. Inflammation of the testicles is observed in wild boars, the weight of which amounts up to 2-4 kg (Bakulov, et al., 1984, Balabanova and Kudryashov, 2019).

Brucella can be transmitted to humans via the consumption of raw or undercooked and incompletely heat-processed meat products of the infected swine. Laboratory and slaughterhouse workers, also pig farmers can become infected through complete skin breakdown and inhalation of *Brucella*-contaminated dust. The disease in humans is associated with long-term fever and infection of musculoskeletal, cardiovascular, nervous, genitourinary and other organ systems.

Materials and methods

The first information about the swine brucellosis was provided by Traum (1914) and the bacteria isolated from the amniotic fluid of an aborted pig were named *Br. abortis suis*.

The causative agents of swine brucellosis belong to the family *Brucellaceae*, the genus *Brucella*, which are multi-shaped (spherical, ovoid, coliform) 0.6-1.5 μm , immobile, gram-negative, aerobic bacteria stained with aniline dyes.

The pathogens grow well in the mediums of brucella agar, meat-pepton-liver-broth (MPLB), meat-pepton-liver-glucose-glycerol agar (MPLGGA) within 2-3 weeks and in case of double seeding even faster (Kudryashova and Svyatkovskovo, 2007, Grigoryan, 2002). Brucellosis of pigs is a zoonotic chronic, endemic, infectious disease and poses considerable threat to human health, so we have a task to study the brucellosis of pig farms in some regions of Armenia and prevent the spread of the infection.

Throughout the last 60 years, for the first time brucellosis carrier state of pigs has been studied and an epidemiological analysis has been carried out within 2020-2022 in Aragatsotn region of Armenia. In order to evaluate the epidemiological situation, the well-known methods of diagnosis were used: epidemiological observations, manifestations of clinical signs and serological reaction. As a result of investigations on the preventive measures for mass animal infection Rose Bengal test (RBT) and the agglutination reaction (AR) were used (Antonov, et al., 1986, Iskandarov, 2007, Popova, 2017, Balabanova and Kudryashov, 2019, Collection of Materials, 2020). Serological investigations were conducted in the central laboratory of the ANAU Scientific Center for Veterinary Medicine and Veterinary Sanitary Examination.

About 2000 units of swine stock aging from 3-month up to 1.5-year old were registered in the Avan community of Aragatsotn region. More than 200 blood samples, in the amount of 3-5 ml, were drawn from the swine breeding farms of the mentioned community (Figure 1). In the schedule of further studies, it is planned to determine the serological type of brucellosis by enzyme-linked immunosorbent assay (ELISA).

In order to exclude other diseases (colibacteriosis, salmonellosis, leptospirosis), the stomach contents, liver, spleen, kidney and femur bone marrow of immature (aborted), underdeveloped and fallen piglets were used as material (Figure 2). Smear-prints were produced from the abovementioned materials and observed by means of microscope. Nutrient media (MPA, MPB) and bismuth-sulfite agar were used for microbiological studies. (Antonov, et al., 1986).

Epidemiological analysis of the studied areas was performed per morbidity and insecurity coefficients, while economic damage was estimated per forced slaughter and infertility indicators (Nikitin and Voskoboynik, 1999, Grigoryan, 2005, Grigoryan, et al., 2004, Grigoryan, et al., 2017).

The morbidity index has been determined per the ratio of diseased animals and the total stock number of animals, while the insecurity coefficient – by the ratio of insecure

sites and the total farm numbers. The economic damage caused by forced slaughter and infertility was determined through formulae 1 and 2.

$$E_d = N \cdot K_m \cdot P - D_{in}, \quad (1)$$

where E_d is the economic damage, N is the number of infected pigs – 5 units, K_m is the average mass of the mentioned pigs – 80 kg, P is the price of the unit product sold – 2500 drams, D_{in} – is the money income generated from the sold meat carcass – 600 thousand drams.

$$E_d = F_p \cdot (P_c \cdot S_n - F_b), \quad (2)$$

where E_d is the economic damage, F_p is the price of a fetus unit at the farrowing time, P_c is the planned fertility rate (8 piglets for uniparous sows), S_n is the number of sows to give birth – 200 heads, F_b is the number of factually born piglets – 1560 heads.

It should be mentioned that the infection of swine brucellosis is probably related to the joint housing of large and small cattle/ruminants and veterinary-sanitary conditions. Recovery of farms vulnerable to brucellosis is organized as a result of successive check-outs (serological). Animals with a suspected positive reaction were isolated and subjected to forced slaughter, and an aqueous solution of a chlorine carrier containing 3 % active chlorine was used to prevent the spread of the pathogen.

Results and discussions

In the result of a year's investigation it became clear that animals' group housing and zoohygienic conditions are considered predisposing factors for infection. As a result of epidemiological, microbiological and microscopic studies, it was determined that miscarriages, death of weak and non-viable piglets was not caused by other diseases, so the research was performed with serological (RBT and AR) methods.

According to Rose Bengal test, a suspicious positive reaction has been observed in 5 sows; the latter has been

grounded in the result of rechecking (after 15-30 days) and application of agglutination reaction.

Dilution of swine's blood serum was performed through the test tube method with 2 ratios: 1:25, 1:50, 1:100, 1:200. In sera of known antigen, unknown antibodies were detected at these dilutions, but 1:25, 1:50, and 1:100 dilutions were considered positive diagnostic titers. The positive results of the above stated reactions were observed through the unaided eye, which was evaluated through crosses (+2, +3, +1) or 50 % and 75 % (Figure 3). In order to prevent the possible spread of swine brucellosis pathogens, the given areas were disinfected with a calcium hydrochloride solution containing 3 % active chlorine.

The results of the brucellosis diagnosis through serological methods confirm that these methods are reliable and effective, which can be used in the system of fighting and curing brucellosis. Epidemiological analysis was conducted per the indices of morbidity, infertility (piglets lethality) and insecurity coefficient. It should be mentioned that out of 200 heads of sow 5 heads were infected, and as a result the morbidity index made 0.25 (2.5 %), whereas per the total head number this index was 0.025 (0.25 %).

It should be mentioned that the economic loss caused by the forced slaughter of diseased animals with 80 kg average weight has been determined per 1 kg meat sale of averagely fattened animal, which made 2500 drams, while in the diseased ones it was 1500 drams. As a result, the damage caused by the forced slaughter of 5 infection carrier sows makes 400 thousand drams. So,

$$Ed = Q \cdot Km \cdot H - Dm = \\ = 5 \times 80 \times 2500 - 5 \times 80 \times 1500 = 400 \text{ thousand drams.}$$

To determine the economic damage caused as a result of infertility of monoparous sows the price of piglets ($P_p=9.1$) at the moment of farrowing has been used, where the live weight of the swines made 9.1 kg (Nikitin and Voskoboynik, 1999).

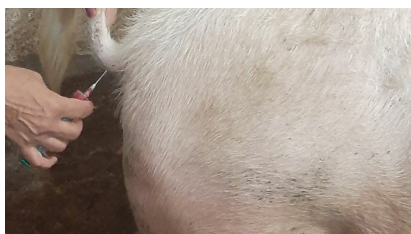

Figure 1. Blood sampling from the inferior tail artery.

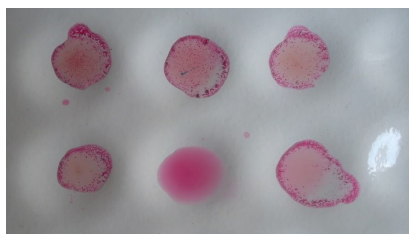

Figure 2. A positive reaction against brucellosis.

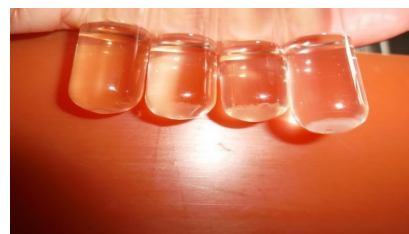

Figure 3. Positive results of AR.

It is worth mentioning that in the result of market competitiveness of farm animals 1 kg weight growth of a swine is equal to 2500 drams. The price of a piglet at the moment of farrowing made 22 750 drams.

$$\text{So, } P_v = 9.1 \times W_g = 9.1 \times 2500 = 22750 \text{ drams.}$$

During the investigations it has been disclosed that due to the infection 1560 piglets were farrowed from 200 heads of monoparous sows instead of 1600 ones and in the result of 40 heads of miscarried foetus the economic damage amounted to 728 thousand drams.

$$E_d = F_v (B_g \times F_w - P_{an}) = 22750(8 \times 200 - 1560) = 910 \text{ thousand.}$$

It can be inferred herefrom that in the result of 2.5 % of swine infection the total economic damage has amounted to 1 mln 310 thousand drams. In the result of epidemiological research analysis the morbidity and insecurity coefficients make 0.025 (2.5 %), 0.0075 (0.75 %) respectively, while the economic damage makes 1 mln 310 thousand drams.

The rural population, as well as animal owning citizens, being wary of infected animals, as well as the products and raw materials of animal origin, within the framework of their responsibilities, take measures to forcibly slaughter sick and infected animals (Iskandaryan, et al., 2012, Eghoyan, et al., 2018).

Conclusion

The created epidemiological situation is multicausal, where the level of veterinary and sanitary conditions are of utmost significance. Detection of brucellosis among the population raises suspicions about the disease of farm animals.

As for diseased and infection carrier animals, it is forbidden to use their carcasses in a smoked state. According to the directive on the fight and prevention of brucellosis disease, slaughtered pork with a positive result for the strain per laboratory research (Br. Suis) is allowed to be used in the production of sausages and preserves, observing to the procedure for decontamination of meat and meat products (Directive, 2013). In the swine-breeding farms, the adult sows and boars should be examined once a year (through serological method) and in case of slaughter it should be done 30 days earlier.

References

- Antonov, B.I., Borisova, V.V., Volkova, P.M. (1986). Laboratory Research in Veterinary Science/ Bacterial Infections: a Handbook.- M.: Agropromizdat, - 352 p.
- Bakulov, I.A., Glushkov, A.A., Nuykin, Ya.V. (1984). Fundamentals of Epizootological Research / In the book: Epizootology and Infectious Diseases of Agricultural Animals / Ed. A.A. Konopatkin. - M.: Kolos, - pp. 60-73.
- Balabanova, V.I., Kudryashov, A.A. (2019). Pathoanatomical Diagnostics of Diseases in Pigs of Growing in Fattening Groups. Electronic Monograph. St. Petersburg, Publishers. CHOUDPO "Institute of Veterinary Biology". - 100 p. <https://doi.org/10.12731/978-5-9902656-0-8>.
- Bessarabov, B.F., Vatutin, A.A., Voronin, E.S. (2007). Infectious Diseases of Animals / Under the Editorship of A.A. Sidorchuk. - M.: Kolos, - 671 p.
- Contemporary Scientific Approaches to Solving the Problem of Brucellosis: Collection of Materials of the Scientific and Practical Conference, Omsk: Publishing House of IP Maksheeva E.A., 2020. - 156 p. <https://doi.org/10.52376/978-5-907419-28-5>.
- Deghdzunyan, K.M., Hambardzumyan, A.D. (1990). Epidemiology, Yerevan, - 368 p.
- Dimov, S.K., Arakelyan, P.K. (2008). Optimization of Anti-Brucellosis Measures in Farm Animals in Siberia. Brucellosis is a Borderline Infection of Animals and Humans, Serpukhov, - pp. 19-20.
- Directive of the Head of Food Safety Service of the Ministry of Agriculture No. 418 of July 16, 2013 on Combating, Preventing and Diagnosing Brucellosis in Farm Animals in the Republic of Armenia.
- Eghoyan, S.G., Mkrtchyan, A.R., Sargsyan, M.A., Andresyan, T.A. (2018). Analysis of the Epizootic Situation of Brucellosis in Cattle and Small Ruminants in the Republic of Armenia // Proceedings of the International Scientific Conference on Topical Issues of Agricultural Development in the Republic of Armenia. ANAU, Yerevan, - pp. 51-54. <https://doi.org/10.36684/69-1-2022-54-60>.
- Grigoryan, S. L., Eghoyan, S. G., Sargsyan, M. A. (2013). Epizootological Situation of Animal Brucellosis in Aragatsotn and Armavir Marzes. International Conf. on Food Security and Biodiversity. ANAU Yerevan, - pp. 38-41.
- Grigoryan, S.L. (2002). Epidemiology and Infectious Diseases of Agricultural Animals. "Astghik" Publishing House, Yerevan, - 641 p.
- Grigoryan, S.L. (2005). Organization and Economics of Veterinary Activities. - Yerevan, ASAU, - 287 p.

13. Grigoryan, S.L., Hovhannisyan, M. H., Yeghoyan, S.L., Sargsyan, M.A. (2004). Methodological Instructions Regarding the Study of the Topic “Economics of Veterinary Measures”, Yerevan, AAA, - 15 p.
14. Grigoryan, S.L., Mkrtchyan, A.R., Yeghoyan, S.G., Sargsyan, M.A. (2017). Economic Damage in the Case of Brucellosis of Cattle on the Example of Balahovit Teaching-Experimental Farm // International Conf. Devoted to Problems of Safety and Quality of Food Products, ANAU, - pp. 30-31.
15. Iskandarov, M.I. (2007). Diagnosis of Brucellosis / Iskandarov M.I., Fedorov A.I., Albertyan M.P. // Animal Husbandry in Russia. - No. 5, - pp. 59-60.
16. Iskandarov, M.I. (2011). Animal Brucellosis in Russia. Epizootological Features and Improvement of Specific Prevention Methods: Abstract of the Doctor of Veterinary Sciences, - 45 p.
17. Iskandaryan, F.R., Sargsyan, M.A., Grigoryan, S.L. (2012). Sanitary Measures against Brucellosis in Disadvantaged Farms // Agrogitutyun, № 5-6, - pp. 350-353.
18. Kolychev, N.M., Gosmanov, P.G. (2006). Veterinary Microbiology and Immunology. Rev. and Updated. M.: Kolos, - 432 p.
19. Kudryashova, A.A., Svyatkovsky, A.V. (2007). Infectious Diseases of Animals. Textbook, Publishing House “Lan”, - 608 p. ISBN 978-5-8114-0710-1.
20. Michiel, V Kroese, Lisa Beckers, Yvette J W M Bisselink, Sophie Brasseur, Peter W van Tulden, Miriam, G.J. Koene, Hendrik, I.J. Roest, Robin, C. Ruuls, Jantien, A. Backer, Jooske IJzer, Joke, W.B. van der Giessen, Peter, T.J. Willemsen (2018). Brucella Pinnipedialis in Greyseals (*Halichoerus Gripus*) and Harbor Seals (*Phoca vitulina*) in the Netheri Ands. 54(3):439-449. <http://doi: 10.7589/ 2017-05-097>.
21. Nikitin, I.N., Voskoboinik, V.F. (1999). Organization and Economics of Veterinary Business: Textbook for University Students, - 4th Ed., Revised and Updated - M.: Humanit. Ed. Center VLADOS, - 384 p. <https:// doi.org/10.33029/9704-6028-3-obs-2020-1-1056>.
22. Popova, A.Yu., Demina, Yu.V., Paskina, N.D., Sheenkov, N.V., Sharova, I.N., Osina, N.A., Kasyan, Zh.A., Shcherbakova, S.A., Kutyrev, V.V. (2017). E71 Epidemiological Surveillance and Laboratory Diagnosis of Brucellosis: Guidelines. - M: Federal Center for Hygiene and Epidemiology of Rospotrebnadzor, - 60 p. ISBN 978-5-7508-1539-5.
23. Vardanyan, A.V., Naghashyan, H.Z., Grigoryan, S.L., Yeghoyan, S.G., Sargsyan, M.A, Mkrtchyan, A.R. (2017). Guideline on Specially Dangerous Infections of Farm Animals, “Antares” Publishing House, RA Yerevan, - 96 p.
24. Vershilva, P.A. (1961). Brucellosis Immunity. M: Medicine, - 414 p.

Accepted on 07.11.2022

Reviewed on 14.11.2022



UDC 638.154.2(479.25)

Study of Acute Bee Paralysis Virus in Some Regions of the Republic of Armenia

J.T. Simonyan*Scientific Center for Risk Assessment and Analysis in Food Safety Area, CJSC*Jsimmk19@mail.ru

ARTICLE INFO

Keywords:

bee,
disease,
acute bee paralysis virus (ABPV),
study,
pathogen

ABSTRACT

Bees are of great importance in agriculture. Recently, beekeeping has been threatened by various viral diseases, which forces beekeepers to look for new solutions in the fight against bee diseases.

Epizootological and laboratory research was carried out in two regions (marzes) of the Republic of Armenia: Aragatsotn (Ashtarak community) and Tavush (Dilijan community). The clinical signs of the studied bees coincided with the symptoms of acute bee paralysis virus (ABPV). As a result of laboratory research, acute bee paralysis virus was confirmed in Tavush marz.

Introduction

Armenians have been engaged in beekeeping since ancient times. Honey, beeswax, royal jelly, bee venom, etc. are obtained from beekeeping (Markosyan, et al., 1984).

There are over 4000 bee species in the order of Hymenoptera, including those that are social or solitary, native or introduced, managed or wild. Honey bee colonies consist of approximately 35 000 individual bees, including sterile female workers, a few hundred male bees (called drones), and a single reproductive female queen bee. Honey bee colonies typically survive multiple years, while the longevity of individual worker bees depends on their caste (i.e., from six weeks to four months for worker bees, approximately eight weeks for drones, and several years

for queen bees) (McMenamin, et al., 2018). The honey bee *Apis mellifera* is an insect that plays an important role in agriculture by pollinating a wide variety of crops and flowers (Morse and Calderone, 2000), increasing their yield (Taranov, 1948). The dependence of worldwide crops on pollinators is extremely deep and during 2005 the global economic value of insect pollination was estimated to be \$212 billion a year (Gallai, et al., 2009). The economic value of honey bee pollination is estimated as several billion dollars; hence, the health of honey bees is an ongoing concern. Although the number of managed honey bee colonies worldwide are steadily increasing, it is not enough to meet the increasing demand for pollination in agriculture. Recent large-scale losses of managed honey bee colonies in some parts of the world and the decline of

wild pollinators have raised awareness and concern of the lack of pollinators (de Oliveira, et al., 2021).

In recent decades, beekeepers around the world have encountered serious honey bee colony losses. During the winter of 2006-2007, a phenomenon called Colony Collapse Disorder (CCD) mysteriously wiped out honey bee colonies from most parts of the United States but the cause of CCD remains unknown. Several factors such as the emergence of new parasites and pathogens, poor nutrition due to loss of forage land and monocropping, excessive and inappropriate use of pesticides and other environmental threats have been supposed to be the reason of widespread bee population declines. Among the potential factors reported so far, viruses have been suggested to be one of the major risk factors that negatively affect bee health (Pichaya Chanpanitkitchote, et al., 2018). The disappearance of bees not only leads to a drastic decrease in the number of many plant and animal species, but also to a reduction in natural resources. Based on the above, it is necessary not to ignore the fall of bees and to apply appropriate medical and preventive measures in time.

The diseases of bees are infectious and non-infectious. The main distinguishing feature of infectious diseases from non-infectious ones is the emergence and development of the epidemiological process (Grigoryan, 2002). Depending on the nature of pathogens, infectious diseases are classified into: prion, viral, bacterial, protozoal and fungal infections. Infection can be direct, that is, via contact with bees, and indirect, through infected feed, water, and vectors. Most often, bees are infected through food and water, rarely through the respiratory tract. Many studies have indicated that honey bee viruses can be shared by wild bee populations of bumble bees and solitary bees. While horizontal transmission of pathogenic viruses between honey bees and wild bees is thought to be ubiquitous and occurs through shared foraging spaces, the prevalence and intensity of these honey bee viruses in wild bee populations are not well documented (Laura J. Jones, et al., 2021).

Recently, beekeeping is increasingly threatened by viral diseases, and new strains of viruses appear that were previously unknown. To date, twenty-two viruses have been described in the honeybee, several of which have been linked to Varroa parasitism (Fanny Mondet, 2014). The mite *Varroa jacobsoni* plays an important role in the spread of viral diseases, which serves as a reservoir and transmitter of the virus (Glinsky and Jarosz, 1992). Virus infection of the family is directly related to the number of *Varroa jacobsoni* ticks present in it. Therefore, all the factors that directly or indirectly influence the levels of

mites will be also influencing the presence of the viruses (Ana Molineri, et al., 2017). In high infestations, pathogens multiply rapidly to lethal limits. Mites are easily infected with the virus from sick bees and transfer it to healthy bees. The impact of viruses on their hosts is exacerbated by the stressors faced by bee populations, including parasites, poor nutrition, and exposure to chemicals (Grozinger and Flenniken, 2019). For example, survival in honeybees infected with viral pathogens is reduced under a monofloral diet (Dolezal, et al., 2019).

The Acute Bee Paralysis Virus (ABPV), is among the diseases that pose a serious risk to beekeeping enterprises globally. It was discovered for the first time during laboratory works on the identification of the causative agent of bee paralysis, i.e. the Chronic Bee Paralysis Virus (CBPV). Pathogens refer to RNA-containing viruses (www.pcheloved.ru). The virus is characterized by its resistance to various esters. It can persist in the bodies of dead bees for about 6 months (www.rsn.tomsk.ru). The acute bee paralysis virus (ABPV) has similar symptoms as the chronic bee paralysis virus (CBPV). However, acute is a term used to refer to increased mortality in bees, unlike with CBPV. Just like most other honey bee diseases, the Acute Bee Paralysis Virus can easily be transmitted from one bee colony to the other and across different hives. Bees are social insects that interact while foraging, making it almost impossible to completely eradicate most of the diseases that affect them. Humans also participate in the spread of diseases through their various activities such as: hive inspection, movement of bees during pollination services, importation of honey bees, and other unhygienic practices. The Acute Bee Paralysis Virus is present in most parts of the world. Countries such as the United States of America, Africa, Asia, Europe, and the Middle East have reported cases of ABPV. Scientists have pointed out that ABPV does not belong to any virus genus but is rather described or grouped under the picornaviruses order Dicistroviridae family. These refer to viruses that affect insects and are described as cricket paralysis viruses. The virus is so common and is spread widely in bee colonies, that it has become almost impossible to completely eliminate it (www.beekeepclub.com).

Acute bee paralysis virus (ABPV) was originally discovered during laboratory experiments as a cause of asymptomatic infections of adult bees (Benjeddou, et al., 2001). ABPV could attack all stages of honeybees, but the most favorable hosts for virus multiplication were the pupae (Chen, et al., 2005a).

The accumulation of viral particles in the brain and especially in the hypopharyngeal glands prove the

foodborne transmission of the virus through the salivary and gland secretions of infected adult bees used to feed the young larvae or mixed in the pollen (Benjeddou, et al., 2001). Infected larvae either die before they are sealed in brood cells if large amounts of virus particles were ingested, or survive to emerge as healthy infected adult bees (Bailey and Ball, 1991).

In some cases ABPV is characterized by the rapid death of adult bees; previously the lethally infected adults show a rapidly progressing paralysis, including trembling, inability to fly, and the gradual darkening and loss of hair from the thorax and abdomen (Maori, et al., 2007a). ABPV can cause infection without obvious symptoms.

Materials and methods

Virus diseases of bees are common all over the world. They are usually underestimated by beekeepers: they can cause serious economic losses if they are associated with other bee diseases. Virtually all viruses are present in apiaries in a latent or asymptomatic form (i.e. no symptoms are seen in the hive). Precipitating events, such as other hive diseases or stressors, can lead to the development of infection and the death of bees or the destruction of colonies and/or affected combs. Seasonal factors and the area where the apiary is located greatly affect the occurrence of bee viruses. To this day many bee viruses have been identified and classified, but there is insufficient information on their worldwide distribution (www.fao.org). This was another reason to start research.

Our goal was to identify the epizootological situation of viral diseases in the Tavush and Aragatsotn marzes of the Republic of Armenia and to confirm the disease in bees with clinical signs of acute paralysis virus by laboratory examination. Laboratory testing is required for the diagnosis of the Acute Bee Paralysis Virus. The tests were carried out in the past in countries such as the United States, Austria, Hungary, and Germany. The UK has also been at the forefront when it comes to the diagnosis of ABPV.

In order to find out the reasons for the decline of bees, the studies were carried out in field and laboratory conditions. The corpses of the bees that died from diseases were collected with tongs and subjected to visual observation. In the samples taken, clinical signs were weakly expressed. Ticks were present on some samples brought from Tavush and Aragatsotn marzes. The abdomen of the bees was swollen and color changed. Some of the samples from the Dilijan consolidated community of Tavush marz showed slight hair loss in the abdomen, which raised suspicion of ABPV. Such hair loss was not present in the samples

brought from the Ashtarak community of Aragatsotn marz. The beekeepers said that before the fall, a trembling of the wings was noticed, and a large number of falls occurred in a certain period. According to the beekeepers, the bees in question were gathered in front of the hives and did not fly even when the beekeeper approached.

Obtained samples were placed in cooler bag and immediately sent to the laboratory. The presence of virus in all investigated samples was detected by polymerase chain reaction (PCR) with a Q1600 Real time PCR device. Nucleic acid extraction was performed using a HiGene™ Viral RNA/DNA Prep Kit (BIOFACT), according to the manufacturer's instructions. After, using the REVERTA-L kit (AmpliSens Biotechnologies), the samples were subjected to reverse transcription.

The PCR data were implemented using BioMaster HS-Taq PCR Kit following the manufacturer's protocol. All cDNAs were amplified by PCR for the related viral target and amplicons were visualized on a 2 % agarose gel and stained by GelRed (Biotium, USA).

Oligonucleotide primer pairs were employed in PCR assays:

F: TTATGTGTCCAGAGACTGTATCCA

R: GCTCCTATTGCTCGGTTTTTCGGT

Our results show the presence of ABPV in honey bees in the Tavush marz.

Results and discussions

The research was carried out in the communities of 2 regions of the Republic of Armenia: Dilijan consolidated community of Tavush marz and the Ashtarak united community of Aragatsotn marz. In the course of the research, we collected dead bees in the mentioned communities. According to the clinical signs, the cause of the recession was ABPV.

According to the research, ABPV was detected in the bees brought from the Dilijan enlarged community by the results of laboratory research, and ABPV was not confirmed in the samples brought from Ashtarak unified community.

A secondary cause of bees becoming infected with ABPV was the removal of bees infected with the disease, during which the bees became infected. The identification of the causes of the primary infection of bees needs more extensive research. In Dilijan community, research was conducted with 3 beekeepers, and in Ashtarak's united community of Aragatsotn marz – with 4 beekeepers. Only one of the 3 beekeepers in the Dilijan community had

infected hives; 5 out of 7 hives were infected, that is – about 70 %.

Vaccines in non-human creatures are not new. Inoculating an insect, however, is very different. In typical vaccines, either a dead or weakened version of a virus is introduced into an animal, whose immune system is then able to create antibodies to fight the disease. Insects, however, don't have antibodies, meaning they don't have the same type of immune response (www.smithsonianmag.com). Like most viral diseases, the Acute Bee Paralysis Virus cannot be controlled by medication (www.beekeepclub.com). This is the problem and the easiest way to solve it is the correct organization of bee treatment and hive disinfection.

Beekeepers were advised to disinfect beehives, position them away from each other to reduce contact between colonies, start fighting against ticks, treat bees with antibiotics, give bees immunostimulants and additional food, drain honey from infected beehives, remove beeswax, melt it and replace it.

Conclusion

According to epidemiological and laboratory research, acute paralysis of bees was detected in the Dilijan consolidated community of Tavush marz. As a result of the laboratory tests of bees based on clinical signs, the acute paralysis of bees in the Ashtarak united community of Aragatsotn marz was not confirmed.

According to the assessment of the epidemic situation in the two marzes, the conducted studies should be large-scale and of continuous nature. At the same time, it is necessary to identify the ways to spread the acute paralysis viral disease of bees and to develop effective measures to fight (treat) it.

An adequate response to the causes of death of bees from acute bee paralysis requires the creation of standardized diagnostics based on clinical signs (if there are clinical signs), and the creation of a regional baseline, which could help beekeepers accurately diagnose at the local level.

Knowing that the immune response of insects differs from the immune response of animals, it is necessary to make the correct organization of bee treatment and hive disinfection.

References

- Alexander, J. McMenamin, Katie, F. Daughenbaugh, Fenali Parekh, Marie, C. Pizzorno and Michelle, L. Flenniken (2018). Honey Bee and Bumble Bee Antiviral Defense, *Viruses*, 10(8), 395. <https://doi.org/10.3390/v10080395>.
- Ana Molineri, Agostina Giacobino, Adriana Pacini, Natalia Bulacio Cagnolo, Norberto Fondevila, Cecilia Ferruffino, Julieta Merke, Emanuel Orellano, Ezequiel Bertozzi, Germán Masciángelo, Hernán Pietronave, Marcelo Signorini (2017). Risk Factors for the Presence of Deformed Wing Virus and Acute Bee Paralysis Virus under Temperate and Subtropical Climate in Argentinian Bee Colonies, May 1;140:106-115. <https://doi.org/10.1016/j.prevetmed.2017.02.019>.
- Bailey, L, Ball, B.V. (1991). *Honeybee Pathology*. Academic Press, London, UK.
- Benjeddou, M., Leat, N., Allsopp, M., Davison, S. (2001). Detection of Acute Bee Virus and Black Queen Cell Virus from Honeybees by Reverse Transcriptase PCR. *Appl Environ Microb* 67:2384-7. <https://doi.org/10.1128/aem.67.5.2384-2387.2001>.
- Chen, Y.P, Higgins, J.A., Feldlaufer, M.F. (2005a). Quantitative Real-Time Reverse Transcription-PCR Analysis of Deformed Wing Virus Infection in the Honeybee (*Apis mellifera* L.). *Appl Environ Microb* 71:436-41. <https://doi.org/10.1128/aem.71.1.436-441.2005>.
- Dolezal, A.G., Carrillo-Tripp, J., Judd, T.M., Miller, W.A., Bonning, B.C., Toth, A.L. (2019). Interacting Stressors Matter: Diet Quality and Virus Infection in Honeybee Health *Roy. Soc. Open. Sci.*, Article 181803, 10.1098/rsos.181803. <https://doi.org/10.1098/rsos.181803>.
- Fanny Mondet, Joachim R. de Miranda, Andre Kretzschmar, Yves Le Conte, Alison, R. Mercer (2014). On the Front Line: Quantitative Virus Dynamics in Honeybee (*Apis mellifera* L.) Colonies along a New Expansion Front of the Parasite *Varroa Destructor*, *PLoS Pathog.* 2014 Aug; 10(8). <https://doi.org/10.1371/journal.ppat.1004323>.
- Gallai, N., Salles, J.M., Settele, J., Vaissiere, B.E. (2009). Economic Valuation of the Vulnerability of World Agriculture Confronted with Pollinator Decline. *Ecol Econ* 68:810-21. <https://doi.org/10.1016/j.ecolecon.2008.06.014>.
- Glinsky, Z., Jarosz, J. (1992). *Varroa Jacobsoni* as a Carrier of Bacterial Infections to a Recipient Bee Host. *Apidologie* 23:25-31. <https://doi.org/10.1051/apido:19920103>.

10. Grigoryan, S. L. (2002). Epidemiology and Infectious Diseases of Agricultural Animals, Yerevan , - p. 5.
11. Grozinger, C.M., Flenniken, M.L. (2019). Bee Viruses: Ecology, Pathogenicity, and Impacts. *Annu. Rev. Entomol.* 64, 205–226 (2019). <https://doi.org/10.1146/annurev-ento-011118-111942>.
12. <http://www.pcheloved.ru/paraloch.html> (accessed on 02.11.22).
13. <https://beekeepclub.com/acute-bee-paralysis-virus-abpv> (accessed on 29.11.22).
14. <https://www.fao.org/3/ca4324en/ca4324en.pdf> (accessed on 24.11.22).
15. https://www.rsn.tomsk.ru/news/rsn/o_virusnom_paraliche_u_pchel (accessed on 02.11.22).
16. <https://www.smithsonianmag.com/smart-news/researchers-create-first-honey-bee-vaccine-180970985/> (accessed on 29.11.22).
17. Laura, J. Jones, Ryan, P. Ford, Rudolf, J. Schilder, Margarita, M. López-Urbe (2021). Honey Bee Viruses are Highly Prevalent but at Low Intensities in Wild Pollinators of Cucurbit Agroecosystems, *Journal of Invertebrate Pathology*, Volume 185, 107667. <https://doi.org/10.1016/j.jip.2021.107667>.
18. Maori, E., Lavi, S., Mozes-Koch, R., Gantman, Y., Peretz, Y., Edelbaum, O., Tanne, E., Sela, I. (2007a). Isolation and Characterization of Israeli Acute Paralysis Virus, a Dicistrovirus Affecting Honeybees in Israel: Evidence for Diversity Due to Intra and Inter-Species Recombination. *J Gen Virol* 88:3428-38. <https://doi.org/10.1099/vir.0.83284-0>.
19. Markosyan, A.H., Hakobyan, N.M., Markosyan, Zh.K. (1984). *Bee Keeping and Breeding Technology*, Yerevan, - p. 3.
20. Morse, R.A., Calderone, N.W. (2000). The Value of Honeybees as Pollinators of US Crops in 2000. *Bee Cult* 128:2-15.
21. Pichaya Chanpanitkitchote, YanpingChen, Jay D. Evans, Wenfeng, Li, Jianghong, Li, Michele Hamilton, Panuwan Chantawannakul (2018). Acute Bee Paralysis Virus Occurs in the Asian Honey Bee *Apis Cerana* and Parasitic Mite *Tropilaelaps Mercedesae*, *Journal of Invertebrate Pathology*, Volume 151, January 2018, - pp. 131-136. <https://doi.org/10.1016/j.jip.2017.11.009>.
22. Taranov, G. F. (1948). *Work in the Collective Apiary*, Yerevan, - pp. 3-4.
23. Victor Henrique Silva de Oliveira, Anna Nilsson, Hyeyoung Kim, Gunilla Hallgren, Jenny Frössling, Lotta Fabricius Kristiansen, Eva Forsgren (2021). Honey Bee Pathogens and Parasites in Swedish Apiaries: a Baseline Study, *Journal of Apicultural Research*, Volume 60, - Issue 5, <https://doi.org/10.1080/00218839.2021.1902679>.

Accepted on 01.11.2022

Reviewed on 05.12.2022



Journal homepage: anau.am/scientific-journal

doi: [10.52276/25792822-2022.4-407](https://doi.org/10.52276/25792822-2022.4-407)

UDC 636.7:[619:616.24-002]

New Approaches to the Treatment of Canine Pneumonia

K.A. Sukiasyan, E.A. Nikoghosyan, A.Yu. Abovyan

Armenian National Agrarian University

T.Ye. Yesayan

Food Safety Inspection Body of the Republic of Armenia

karinesukiasyan58@gmail.com, erik-nik69@yandex.ru, arevabovyan@yahoo.com, tigrany@yandex.ru

ARTICLE INFO

Keywords:

*dog,
pneumonia,
germ,
virus,
Gamavit,
Moxifort*

ABSTRACT

The main goal of this study is to develop an effective method for the treatment of pneumonia in dogs. Clinical and hematological studies of the dogs sick with pneumonia as well as bacteriological examination of sputum were carried out to determine the bacterial composition and the sensitivity to antibiotics. Our recommended approach on the use of Moxifort, Gamavit, and ACC has manifested a high therapeutic effect.

Introduction

Canine pneumonia is common in the dogs of all breeds and ages. Pneumonia morbidity ranges between 45-50 % and pneumonia mortality - 34-36 % in the animals. Pneumonia is accompanied by exhaustion, severe fever, cough, rales in the lungs, sclerosis spots, severe decrease of the airway surface of lungs, expanding hypoxia, rapid-onset suffocation, severe cardiovascular and respiratory failure, intoxication signs, drop in the life activities and working capacities of the animals which sometimes lead to death (Belov, 1990, Ketiladze, et al., 1986, Lebedev, et al., 2022, Matveev, 1997, Fedyuk and Aleksandrov, 2001).

Air contamination with pathogenic viruses and bacteria as well as the bacterial and viral diseases in lungs contribute to

the development of canine pneumonia. Besides, the failures in animal care and management rules, such as keeping them in wet and cold premises, exposing an animal to the draught and sharp fluctuations of air temperature, bathing with cold water or making long walks in the cold weather, contribute significantly to the contraction of canine pneumonia. Besides, deficiency of biologically active substances, vitamins and microelements in the diet contributes to the development of pneumonia (Lipnitsky, 1996, Marchuk and Berbentsova, 1989, Yeleseyev, 1989, Nimand and Suter, 1998, Plyashchenko and Sidorov, 1979).

Many scientific works are already dedicated to the treatment and prevention of canine pneumonia, but the problem still raises interest in terms of developing faster and more effective ways of pneumonia treatment.

Materials and methods

The main goal of research is to develop an effective way of treating the canine pneumonia with the use of strong and wide-spectrum antibiotics, mucolytic and immunostimulating agents. The studies were carried out in winter of 2020-2021 at the Chair of Therapy, Diagnostics and Pharmacology of the Armenian National Agrarian University. The experiments involved 10 dogs aging from 2 to 4 years old, divided into two experimental groups with 5 dogs per group.

The first group was treated in the traditionally practiced way. Each animal was injected intramuscularly with Ceftriaxone antibiotics in a dose of 0.12 ml per each kilogram, once a day, as well as Broncholytin as broncholytic agent was given to them in a dose of 2 teaspoons, thrice a day.

The second group of animals was treated with a combination of drugs recommended by us: Moxifort was administered intramuscularly in a dose of 0.1 ml per each kg, once a day, and Acetylcysteine, 1 tablet once a day, and also Gamavit – intramuscularly, 0.5 ml per each weighing kg, twice a day. The treatment lasted 8 days.

All animals were subject to daily clinical examination (general state, body temperature, pulse and respiratory rate) and checkup of hematological indicators (red and white cell counts, hemoglobin contents, erythrocyte sedimentation rate). The blood cell count was performed by use of a hemocytometer, the hemoglobin content was measured with a SALI hemoglobinometer, and the sedimentation rate was evaluated using Panchenkov's micromethod.

To determine the species composition and quantity of pathogenic bacteria in the inflammatory bronchial fluid of sick dogs, we took samples and performed a seeding on nutrient media. Sampling was carried out with the use of sterile cotton tip, which we inserted into the animal's nostril by making rotating movements. Then we placed the

tips into the sterile test tubes containing 1 ml of saline. In advance, we prepared another 4 sterile test tubes containing 1 ml of meat-infusion broth. Using a sterile syringe, we filled 1 ml of saline saturated with fungal fluid from nasal cavity into the first test tube, getting 1:10 rate of dilution. Then we transferred 1 ml of liquid from the first tube to the second test tube, getting 1:100 dilution rate. In the same way, we got 1:1000 and 1:10 000 dilution rates. From the last dilution of 1:10 000 we made a seeding in the volume of 0.2 ml on the surface of meat-infusion broth, which we spread on the surface of the broth with a sterile swab. Then, we placed the nutrient media into a thermostat at 37 °C temperature. After 24 hours, we put the Petri dish with the meat-infusion broth on a black paper, turned it upside down and performed the study and count of the emerged gouts.

We detected white, as well as transparent, round smooth-edged bulged mucous dewdrop-like gouts. Purple diplo- and streptococci were detected in the Gram-stained microbiological smears made from I type of the gouts, while in the smears made from II type of gouts we detected red bipolar coccidial germ. In order to determine the sensitivity of germs to the antibiotics, we placed the paper discs saturated with antibiotics (Gentamicin, Amoxiclav, Cyprinol, Moxifort, Benzylpenicillin, Bicillin-3) on the surface of sterile meat-infusion broth on the different sides of Petri dish; then we made a seeding in the diluted sample by spreading it on the surface of broth with the use of a sterile spatula and placed the nutrient media into the thermostat for 24 hours at 37 °C temperature. We calculated the rate of sensitivity by measuring the sizes of suspension area (in cm) in the microbial fouling around the discs; the larger suspension area is, the more sensitive the respective germs to the tested antibiotic agents are. From the agents tested by us, Amoxiclav gave rise to 0.7 cm of microbial fouling suspension area and Moxifort – to 1.8 cm. In case of other antibiotics, the suspension area was too insignificant.

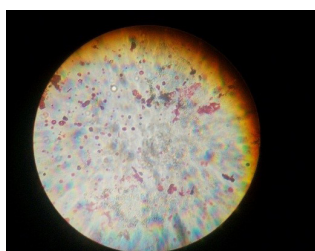

Figure 1. *Staphylococcus*.

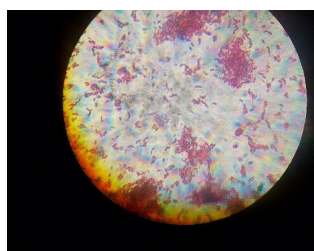

Figure 2. *Pasteurella*.

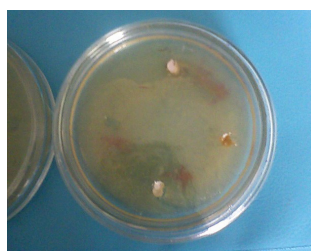

Figure 3. *Fouling Suspension Area on the Meat-Infusion Broth.*



Figure 4. *Germ Culture.*

Within the framework of the studies, detection of animals sick with pneumonia and disease diagnostics were performed in the clinics where the further management and clinical-laboratory examination of sick animals were organized as well.

Animals with pneumonia were brought to the clinics at different stages of the progress and development of disease. Based on the animal health conditions and the results of examination, the most optimal treatment schedule was developed.

Results and discussions

As the Table 1 shows, before the treatment all experimental animals had a decreased red blood-cell count making 2.5×10^{12} l on average, an increased white blood-cell count making 22×10^9 l on average, decreased hemoglobin making 60 g/l on average, and increased ESR making 45 mm/h on average. In the animals of the first test group that were treated with the traditionally practiced Amoxiclav and Broncholytin medicines, the recovery of hematological parameters took place very slowly, and the positive changes in blood pattern were insignificant in the first days of treatment. Recovery of these parameters came up in the last days of treatment, about on day 7 or 8, while in the second group of animals treated through our proposed approach with the use of Moxifort, ACC, Lasolvan and

Gamavit the recovery of hematological parameters started from the very first days of treatment, about on day 2 to 4, and already on the 7th day of treatment these parameters were fully recovered, which proves the high therapeutic efficacy of the our proposed approach.

The following manifestations were recorded in all animals sick with pneumonia: body temperature rise, accelerated pulse and respiration, signs of the suffocation caused by hypoxia and decrease in the airway surface of lungs, severe cardiovascular and respiratory failure, and intoxication signs.

Table 2 presents the results of clinical checkups in sick animals, and it proves that in the animals of 1st test group that were treated under the traditional approach the clinical parameters (body temperature, pulse, respiration) recovered slowly (on the day 7 or 8 of the treatment), unlike the animals of 2nd test group that were treated with our proposed approach, whose clinical parameters started to normalize from day 2 to 4 of the treatment and completely recovered on the 7th day of treatment. The same is for the clinical course of disease: amelioration of signs in the 1st group of animals was slower and they recovered on day 7 or 8 of the treatment, while the improvement of general conditions in the 2nd group of animals began on the day 2 to 4 of the treatment and already on 7th day of treatment the animals were in almost good health.

Table 1. Hematological data of the animals affected with Pneumonia*

Parameter	Reference range	Before treatment	Group 1				Group 2			
			Day 2	Day 4	Day 6	Day 8	Day 2	Day 4	Day 6	Day 8
Erythrocytes, 10^{12} l	5.5-8.5	2.5 ± 4.32	3.0 ± 4.34	3.8 ± 3.28	4.0 ± 3.14	5.2 ± 2.93	4.5 ± 4.18	5.3 ± 3.18	5.9 ± 2.54	7.8 ± 1.97
Leucocytes, 10^9 l	6-17	22 ± 2.43	21 ± 1.64	20 ± 1.11	19 ± 1.04	18 ± 1.16	18 ± 1.58	17 ± 1.42	10 ± 1.36	8 ± 0.83
ESR, mm/h	2-8	45 ± 0.28	38 ± 0.14	30 ± 0.14	25 ± 0.12	19 ± 0.11	38 ± 0.26	25 ± 0.24	15 ± 0.18	10 ± 0.17
Hemoglobin, g/l	120-180	60 ± 0.45	68 ± 0.48	90 ± 0.34	100 ± 0.32	119 ± 0.54	95 ± 0.52	110 ± 0.43	120 ± 0.36	130 ± 0.21

Table 2. Clinical data of the animals affected with Pneumonia*

Parameter	Reference range	Before treatment	Group 1				Group 2			
			Day 2	Day 4	Day 6	Day 8	Day 2	Day 4	Day 6	Day 8
T, °C	38.5-39	41.0 ± 4.71	40.9 ± 3.51	40.5 ± 3.91	39.9 ± 3.01	39.6 ± 2.12	39.9 ± 4.21	39.6 ± 3.94	39.0 ± 2.92	38.8 ± 2.21
P, BPM	90-110	140 ± 4.13	130 ± 3.62	125 ± 2.31	119 ± 1.14	100 ± 0.36	110 ± 3.81	100 ± 2.51	100 ± 2.01	90 ± 1.32
R, bpm	16-18	45 ± 3.78	40 ± 2.71	35 ± 1.56	29 ± 1.34	25 ± 3.56	35 ± 3.24	28 ± 2.36	20 ± 2.28	17 ± 2.15

*Composed by the authors.

Based on the above mentioned, it can be concluded that an effective approach to treatment of canine pneumonia is the joint use of (1) Moxifort, our selected fluoroquinolone medicine, which possesses strong antimicrobial characteristics affecting a wide range of pathogenic microorganisms, (2) Acetylcysteine (ACC) which has strong antispasmodic and expectorant effect enabling a quick clearance from inflammatory exudate and restoration of ventilation in the respiratory tract, and (3) Gamavit, immune-stimulating agent specific with its high efficacy, which enables to increase body's immunity and defense in a proper rate.

Conclusion

During the studies, we have treated the bacterial pneumonia in dogs mainly caused by the pathogenic bacteria: Staphylococci, Streptococci, Diplococci, Pasteurella, Klebsiella and other pathogenic microorganisms. In all the cases which we observed, poor care conditions contributed to the disease, specifically a long stay of animals outdoor in cold weather and keeping animals in cold and damp shelters, which contributed to the decrease in immunity, development of bacterial infection in the lungs, and contraction of pneumonia. In all of the observed cases, pneumonia was specific with a complex nature and the large parts of lungs affected by pathologic processes. Disease was followed by a rise of body temperature, debilitating fever, dehydration, intense cardiovascular and respiratory failure, arrhythmia, tachycardia, and increasing suffocation. Disease caused deviation in both the clinical and the hematological indicators. Inflammation and intoxication resulted in hypochromic anemia, significant decrease of erythrocyte count and hemoglobin contents, increase of ENA, and leukocytosis induced by the mobilization of body defense. In order to make precise diagnosis of the disease, we carried out a comprehensive examination of sick animals, including the clinical, hematological, microbiological, and radiological checkups. To address the disease, we proposed a new treatment of pneumonia using the antibiotics, mucolytic drugs and immunostimulants. We chose Moxifort as an antibiotic medicine, which is classified to the fluoroquinolone agents and which has a broad-range effect and strong antimicrobial characteristics, Lasolvan, and Acetylcysteine as the mucolytic agents, which have antitussive, antiseptic and bronchodilatory actions, Gamavit as an immune-stimulating agent intended for the veterinary use only, which is an adaptogen with strong immune-boosting action. We compared the effectiveness of our proposed treatment for canine pneumonia with

the effectiveness of traditional treatment. The successful selection and combination of the medicines affects all elements of disease and enables reduction in duration of pneumonia treatment and quicker recovery of sick animals as compared to treatment of animals with the drugs used in traditional practice.

In order to treat the canine pneumonia effectively, a complete examination of sick animals (clinical, laboratory, instrumental) is required. As a precaution, the infectious and invasive diseases causing pneumonia shall be prevented in time, the animal feeding shall be improved, the rations shall be balanced in the terms of all necessary nutrients to reinforce the immunity in animals, the animal care and welfare shall be improved to provide the animal management in the clean, well-ventilated, dry and heated (in wintertime) conditions. It is necessary to avoid hypothermia in animals, keeping them in damp and cold shelters, and taking them outdoor for long walks in cold weather.

References

1. Belov, A.D. (1990). Canine Diseases. Handbook. Moscow: Agropromizdat, - pp. 23-46 (in Russian).
2. Ketiladze, Y.C., Ivanova, L.A., Yeliseyeva, I.Y. (1986). Importance of Various Respiratory Viruses in the Deep-Rooted Non-Specific Bronchopulmonary Processes // Virology Issues. - №. 3, - pp. 310-314.
3. Lebedev, A.V., Starchenkov, S.V., Khokhrin, S.N., Scherbakov, G.G. (2000). Non-Communicable Diseases in Dogs and Cats. – St. Petersburg: GRIORD, – p. 296 (in Russian).
4. Lipnitsky, S.S. (1996). Handbook on the Diseases of Domestic and Exotic Animals. Minsk: Urozhay, - pp. 264-269 (in Russian).
5. Marchuk, G.I., Berbentsova, E.P. (1989). Acute Pneumonia, Immunology, Severity Score, Clinical Findings, and Treatment. Moscow: Nauka, – p. 340 (in Russian).
6. Yeliseyev, A.N. (1998). Canine Diseases. Moscow: Rosagropromizdat (in Russian).
7. Niemand, H.G., Suter, P.F. (1998). Diseases in Dogs. - Moscow: Aquarium, – p. 825 (in Russian).
8. Plyaschenko, S.I., Sidorov, V.T. (1979). Autarcesis of Animal Body - Leningrad: Kolos, – p. 184.
9. Matveyev, A.V. (1997). Diseases in Dogs and Cats. Nizhny Novgorod, - p. 204 (in Russian).
10. Fedjuk, V.I., Aleksandrov, I.D. (2001). Handbook on Canine and Feline Diseases. Rostov-on-Don: Feniks (in Russian).

Accepted on 08.06.2022
Reviewed on 21.06.2022



Journal homepage: anau.am/scientific-journal

doi: [10.52276/25792822-2022.4-411](https://doi.org/10.52276/25792822-2022.4-411)

UDC 663.374.393:663.326

Study of the Possibility of Honey Wine Production Using New Active Dry Yeasts and Yeasts Derivatives

Sh.A. Bakhshetsyan, E.R. Gevorgyan, M.N. Mikayelyan

Armenian National Agrarian University

shahanebakhshetsyan1822@gmail.com, elyanora.gevorgyan@mail.ru, mikayelyan.m@mail.ru

ARTICLE INFO

Keywords:

*honey,
active dry yeast,
fermentation,
yeast autolysates,
organic acids,
color composition,
total phenols*

ABSTRACT

The current article is dedicated to the study of the possibility of obtaining alcoholic beverages made by fermenting natural honey (honey wine) using different types of dry active yeast and yeast autolysis derivatives. The data obtained from the results of the research will be interesting both from the scientific and production point of view and allow us to conclude that the selected yeasts can be used for the production of such alcoholic beverages.

Introduction

These research activities were carried out with the support of the Innovative Agriculture Training and Learning Camp (AGRI CAMP) Program which is financed by The United States Agency for International Development (USAID) and implemented by International Center for Agribusiness Research and Education Foundation (ICARE).

The contents are the responsibility of the author/s and do not necessarily reflect the views of USAID or the United States Government.

Honey wine is probably considered to be the first alcoholic beverage in human history, the first mentions of which date back to 7000 years BC. As a result of excavations in China, Egypt, India, and other countries, many clay containers (karas) and jars were found, the remains of which were found to contain honey (Bayon, 1997, Jorczyk, et al., 1977).

Honey is a natural product rich in biologically active substances, the composition of which depends on the floral origin – climate, environmental and seasonal conditions – terroir (Al-Mamary, et al., 2002). The aroma and taste of honey are due to the nectar of plants. Honey contains useful trace elements: iodine, iron, potassium, phosphorus, magnesium, folic acid, and vitamins B_2 and B_6 . The viscosity of honey depends on the content of sugars; honey with high fructose content is thicker than honey with glucose and other sugars. The amount of fructose is predominant over other sugars in honey, resulting in the fermentation process of honey wine taking longer (Carol, et al., 2006).

Honey wine is made from the alcoholic fermentation of diluted honey. As a result, the beverage is containing 8 to 18 % by volume of ethanol (Antonio Iglesias, et al., 2014). Honey fermentation is a time-consuming process that lasts from weeks to months, and the quality of the final

product is highly variable and depends on several factors: the type and composition of honey, the yeast strain, and fermentation conditions, the fermentation improvers used, etc. (Navrátil, et al., 2001).

Materials and methods

To carry out research, the company “Greenwoods” LLC supported us by providing natural Armenian mountain honey (AST 228-2003), which was selected for its unique relatively weakly expressed delicate and neutral taste and smell, to better identify the characteristics of the yeasts.

Active dry yeast and fermentation improvers used for this research were provided by LabCare&Consulting company, which is the official distributor of Fermentis in Armenia. Samples were made according to yeast strains: 1. SafCeno™ VR-44 (control) 2. SafCider™ AB-1, 3. SafCider™ AC-4, 4. SafCider™ AS-2, 5. SafCider™ TF-6 (www.fermentis.com).

During the fermentation, we also added yeast derivatives: SpringFerm™ and SpringCell™. SpringFerm™ is a fermentation activator based on partially autolyzed yeasts, around 3 times richer in available nitrogen than basic inactivated yeast. Directly issued from yeast, it brings amino acids, sterols, minerals & vitamins. The absence of these compounds can be harmful to complete fermentation (www.fermentis.com).

SpringCell™ is the original pure yeast cell hull. Yeast cell hulls are performing fermentation aids that allow acting efficiently against stuck & sluggish fermentation. SpringCell™ yeast hulls are the original cell hulls patented by the university of Bordeaux (Lafon-Lafourcade, et al., 1984, www.fermentis.com). Prepared honey was dissolved in pure drinkable water at 20-25 °C. According to the refractometer, the total sugar content of the obtained honey juice (must) was 21 %. Then it must be sulfited by potassium metabisulfite in a dosage of 60 mg/l.

The active acidity pH of the honey was 3.32. Although the pH indicator is considered acidic and it is the same as in grape juice, we added 50 g/hl of DL-malic, and citric acids to the honey must, bringing the pH level of the juice to 3.00, as well as Spring Ferm™ at the rate of 4 g/hl for supplying nutrients for yeast growth and fermentation.

The honey was evenly filled in glass jars, to each of which 30 g/hl of dry active yeast strains were added and were closed with fermentation airlock valves. The fermentation process was carried out at a temperature of 16-18 °C. After one week, we added the calculated amount of Spring Ferm

which is necessary to provide the necessary amount of fermentable nitrogen (YAN) for each yeast in the jars.

During the fermentation process when 2/3 of the sugar was fermented we also added SpringFerm™ and Spring Fell™ concentration of 20 g/hl as suggested on Fermentis protocols.

OIV and EAEU GOSTs methods were used to evaluate the physicochemical indicators of wines. Sugar content was determined by refractometry and Bertrand methods (GOST 13192-73). Alcohol content: OIV-MA-AS312-01A, Total acidity: OIV-MA-AS313-01, Volatile acidity: OIV-MA-AS13-02, Free and total sulfur dioxide: OIV-MA-F1-07, Chromatic characteristics: OIV-MA-AS2-07B, Folin Ciocalteu index with OIV-MA-AS2-10 methods (International Organization of Vine and Wine, 2022). Organic acids were determined by liquid chromatography with an Agilent 1100 Series instrument equipped with an Agilent 1260 Infinity DAD detector (Schneider, et al., 1987). Color characteristics were determined using a UNICO 2802 UV/VIS photo spectrometer at 420, 520, and 620 nm in a 1-cm-thick cuvette.

Results and discussions

The content of reducing sugars (fructose and glucose) in the honey sample was 801.8 g/l, and the number of total sugars was 827.3 g/l. The difference in the obtained results, 25.48 g/l can be considered the amount of sucrose, because sucrose is reducing sugar.

Once or twice a week, the containers were mixed and the sugar content of the samples was measured (Figure 1).

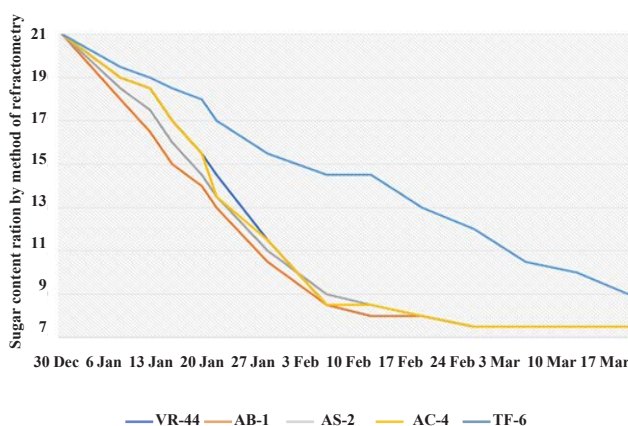

Figure 1. Fermentation graph of honey must (30.03.2022) (composed by the authors).

As it has been shown in the graph, the four types of yeast strains we selected for the research: VR-44, AB-1, AS-2, and AC-4 completed fermentation in 45 days, and only TF-6 strain completed fermentation in 75 days (Navrátil, M., et al, 2001).

After the end of alcoholic fermentation, we did sampling for physicochemical analysis. For the rest of the wines, samples for further preservation and maturation potassium metabisulphite at 20 mg/l was added.

The results of laboratory analyses were studied and presented in Table 1. The amount of titratable acidity in the honey was 0.32 g/l. The titratable acidity of the samples used VR-44, AB-1, and AS-2 yeast is 3.97 g/l, and AC-4 – 3.3 g/l and TF-6 – 3.75 g/l. The increase in titratable acidity is explained by the formation of new acids as a result of fermentation, as well as by the amount of malic acid and citric acid added before the fermentation.

Since the fermentation process was quite prolonged during our research, the high content of volatile acidity obtained as a result of the research in all samples is also legitimate, which is possibly the result of undesirable microbial processes, since the medium contained sugars and exhausted yeast (Navrátil, et al., 2001). The maximum amount of volatile acidity in the samples was recorded at

TF-6: 0.94 g/l, the minimum at VR-44: 0.56 g/l, and at AB-1, AC-4, and AS-2, respectively: 0.72 g/l, 0.64 g/l, and 0.86 g/l.

The active acidity pH of honey was 3.44, then after adjusting the acidity and carrying out fermentation, the pH of the wines decreased to 3.0. After fermentation, the active acidity in the samples was 3.0-3.04. The amount of alcohol produced by the tested yeasts was interesting, because the tested yeast, according to the manufacturer's Fermentis brand, is intended for the production of apple cider.

According to the results of the research, the alcohol content was the highest at 12.3 vol. % (AB-1, AS-2, AC-4) and the lowest indicated: 11.9 % in TF-6, and for the control – VR-44 – 12.2 vol. % (Antonio Iglesias, et al., 2014). Residual sugar content significantly affects the taste and quality of the drink. The sugar content of honey was 227.5 g/l. As a result of yeast activity, most of the sugar was fermented, as a result of which the most fermented sample was VR-44, the residual sugar was 11.58 g/l, and the highest content of residual sugar was observed in sample TF-6 – 19.55 g/l. In other samples AB-1, AS-2, AC-4, respectively: 13.0 g/l, 12.45 g/l, 12.1 g/l. The sugar content in those types of alcoholic beverages is usually classified as semi-dry.

Table 1. The results of the physicochemical analysis *

Parameters	unit	Honey must	SafOENO VR-44	SafCider AB-1	SafCider AS-2	SafCider AC-4	SafCider TF-6
Free sulfur dioxide	mg/l	11.17	4.07	4.7	5.02	2.8	4.07
Total sulfur dioxide	mg/l	51.53	35.4	36.37	41.39	37.6	41.39
Reductions SO ₂	mg/l	2.48	3.13	3.13	3.76	3.13	4.07
Titratable acidity	g/l	0.32	3.97	3.97	3.97	3.3	3.75
Volatile acidity	g/l	-	0.56	0.72	0.86	0.64	0.94
Active acidity pH	-	3.44	3.00	3.02	3.04	3.02	3.03
Alcohol, by vol.	%	-	12.2	12.3	12.3	12.3	11.9
Sugars	g/l	227.5	11.58	13	12.45	12.1	19.55
Yeast assimilable nitrogen (YAN)	mg/l	53.2	42,0	44,8	42,0	42	36.4
Total phenols	mg/l	61.66	112.61	123.36	124.28	114.76	113.8
Folin Ciocalteu index	-	1.40	2.56	2.8	2.82	2.61	2.59
Aldehydes	mg/l	3.96	30.8	36.96	89.76	34.76	47.08
Acetals	mg/l	42.48	38.9	21.24	49.56	29.5	50.74

*Composed by the authors.

Yeast assimilable nitrogen (YAN) or fermentable nitrogen is the combination of free amino nitrogen (FAN), ammonia (NH_3), and ammonium (NH_4^+) that is available for yeast. Outside the fermentable sugars glucose and fructose, nitrogen is the most important nutrient needed to carry out a successful fermentation that doesn't end prior to the intended point of dryness or sees the development of off-odors and related wine faults. As a result of nitrogen metabolism during fermentation, the wine's bouquet and style are also formed. Depending on the characteristics of the yeast, the ratio of fermentable nitrogen (mg/l) to sugar (g/l) according to the selected yeast is 0.7 for VR-44, AB-1, AS-2, AC-4, and 0.9 for TF-6. In the honey must concentration of YAN was 53.2 mg/l, 120 mg/l of SpringFerm was added before starting the fermentation, which helped to increase the amount of organic nitrogen by 120 mg/l.

The results of the analysis showed that the amount in the samples after fermentation was: VR-44 – 42.0 mg/l, AB-1 – 44.8 mg/l, AS-2 – 42.0 mg/l, AC-4 – 42.0 mg/l, TF-6 – 36.4 mg/l, which is sufficient for the stability of the obtained wine (Ribereau-Gayon, et al., 2006).

There is a lack of data on phenolic content in honey (Al-Mamary, et al., 2002). We studied the content of total phenols concentration in honey and recalculated it according to gallic acid, which was 61.66 mg/l. Taking into account that the honey was diluted 4 times, the content of total phenols in honey would be 246.64 mg/l.

After fermentation, the concentration of total phenols increased twice, even though no additional tannins were added to the must. The number of total phenols in fermented samples was: VR-44 – 112.61 mg/l, AB-1 – 123.36 mg/l, AS-2 – 124.28 mg/l, AC-4 – 114.76 mg/l, TF-6 – 13.8 mg/l. The increased amount of total phenols could have occurred either as a result of the biological activity of the yeast or from the addition of yeast autolysates, in which there may also be gallic acid derivatives.

The Folin Ciocalteu index is an international method for determining the total content of phenolic compounds, which is used in winemaking (International Organization of Vine and Wine, 2022). Folin Ciocalteu index in the honey must was: 1.4, in wine samples: VR-44 – 2.56, AB-1 – 2.8, AS-2 – 2.82, AC-4 – 2.61, TF-6 – 2.59, respectively.

The concentration of aldehydes in honey beverages usually ranges from 18.2 to 125.5 mg/l (Antonio Iglesias, et al., 2014, Victoria Moreno-Arribas, et al., 2009). According to the results of our research, the number of aldehydes in the honey was 3.96 mg/l. The minimum amount of aldehydes after fermentation recorded in the wine

samples was 30.8 mg/l for VR-44, which corresponds to the technical sheet data of this strain. The VR-44 strain is used in the production of slightly oxidized champagne wines. The number of aldehydes among the investigated strains according to the strain by growth order was: AC-4 – 34.76 mg/l, AB-1 – 36.96 mg/l, TF-6 – 47.08 mg/l, and the maximum – AS-2 – 89.76 mg/l.

The amount of acetals in the must was 42.48 mg/l, and the amount of acetals in wines decreased by: AB-1 – 21.24 mg/l, AC-4 – 29.5 mg/l, VR-44 – 38.9 mg/l, and increased: AS-2 – 49.56 mg/l and TF-6 – 50.74 mg/l.

Organic acids are also important components of wine, which are important for the evaluation of wine's microbiological stability, aroma, and quality (Table 2). As a result of yeast activity, new acids were found in honey wine, which were not found in honey must, for example, malic acid, ascorbic acid, lactic acid, citric acid, and fumaric acid (Ribereau-Gayon, et al., 2006).

DL-malic acid, and citric acid were added at the amount of 0.5 g/l to increase the acidity of the honey must. After fermentation, malic acid concentrations were changed under the influence of yeast strains VR-44, AB-1, AS-2, and AC-4, respectively: 0.63 g/l, 0.66 g/l, 0.55 g/l, 0.59 g/l, and decreased respectively up to 0.47 g/l in TF-6 yeast sample. The amount of formic acid in must was 0.1255 g/l, but the amount in wines decreased up to VR-44 – 0.055 g/l, AB-1 – 0.0509 g/l, AS-2 – 0.066 g/l, AC-4 – 0.0454 g/l, TF-6 – 0.0739 g/l (Kazumyan, et al., 2022).

In our experiments, even though the fermentation process took quite a long time, a decrease in the amount of malic acid was observed only in the sample TF-6 up to 0.470 g/l, the decrease in the amount of malic acid is only 0.03 g/l. In all other samples, no decrease in the amount of malic acid was observed, although the manufacturer describes some yeasts as consuming malic acid. The amount of malic acid in the samples increased from 0.5 g/l up to VR-44 – 0.6347 g/l, AB-1 – 0.6674 g/l, AS-2 – 0.5558 g/l, and AC-4 – 0.59 g/l.

Although no ascorbic acid was added to the honey must, fermentation revealed trace amounts of ascorbic acid in both wine samples. It can be assumed that it is related to the characteristics of the yeast AS-2 – 11.0 mg/l, TF-6 – 13.8 mg/l.

Lactic acid is produced during alcoholic fermentation in the amount of up to 1.0 g/l. In young, unaged wines, lactic acid can also be produced from malic acid under the influence of certain types of lactic acid bacteria. Taking into account the fact that lactic acid was not found in the honey must, after fermentation it was newly formed in all samples in the following amounts: VR-44 – 0.8419 g/l, AB-1 – 0.4365 g/l, AS-2 – 0.7405 g/l, AC-4 – 1.062 g/l, TF-6 – 0.4946 g/l.

The content of acetic acid in wines is limited: no more than 1.2 g/l. Depending on the yeast strain, some amount of acetic acid is produced during fermentation by the oxidation of acetaldehyde, as a result of the activity of lactic acid and acetic acid bacteria under aerobic conditions (Victoria Moreno-Arribas, et al., 2009). Trace amounts of acetic acid were found in the honey must 0.0173 g/l, after fermentation its amount increased up to VR-44 – 0.4527 g/l, AB-1 – 0.6608 g/l, AS-2 – 1.0212 g/l, AC-4 – 0.672 g/l, TF-6 – 1.0434 g/l.

Citric acid is produced as a by-product during alcoholic fermentation. It is also added to adjust the acidity and pH of the must. Since we added 0.50 g/l of citric acid to honey must, we have interesting results after fermentation: in the case of VR-44, the amount of citric acid decreased up to 0.4573 g/l, in samples AB-1, AS-2, AC-4, TF-6 citric acid content increased respectively: 0.5683 g/l, 0.7157 g/l, 0.6133 g/l, 0.5422 g/l.

The amount of succinic acid prevails over the amount of all acids. Formed during alcoholic fermentation from glutamic acid by deamination and decarboxylation 0.4232 g/l of succinic acid was detected in the must, after fermentation

its amount significantly increased. The minimum quantity was recorded in TF-6 sample: 0.7756 g/l, maximum: AC-4 – 1.2406 g/l, VR-44 – 1.2334 g/l, AB-1 – 1.0757 g/l, AS-2 – 0.9871 g/l.

Fumaric acid ensures the microbial stability and freshness of the wine, which also allows to reduce the amount of SO₂ used. Fumaric acid is effective in reducing or preventing the growth of lactic acid bacteria in wine. It is present in small amounts in a wide range of biological systems because it is an intermediate metabolite of the citric acid cycle. Fumaric acid is produced by the dehydration of malic acid and succinic acid. As a result of our research, it became clear that there is no fumaric acid in honey must, but as a result of yeast activity, VR-44 – 1.1 mg/l, AB-1 – 0.7 mg/l, AS-2 – 0.6 mg/l, AC-4 – 1.0 mg/l, TF-6 – 1.1 mg/l.

To determine the color characteristics of the samples, photoelectric colorimetry was carried out. Color characteristics in wine samples were determined according to the three main colors, yellow, red, and blue absorption coefficients (International Organization of Vine and Wine, 2022). The data calculated as a result of the processing of the results obtained by the device are presented in Table 3 and Figure 2.

Table 2. Organic acids*

Organic acids	unit	Honey must	SafCEnoTM VR-44	SafCider AB-1	SafCider AS-2	SafCider AC-4	SafCider TF-6
Formic acid	g/l	0.1255	0.0551	0.0509	0.0662	0.0454	0.0739
Malic acid	g/l	-	0.6347	0.6674	0.5558	0.59	0.4707
Ascorbic acid	mg/l	-	-	-	11.0	-	13.8
Lactic acid	g/l	-	0.8419	0.4365	0.7405	1.062	0.4946
Acetic acid	g/l	0.0173	0.4527	0.6608	1.0212	0.672	1.0434
Citric acid	g/l	-	0.4573	0.5683	0.7157	0.6133	0.5422
Succinic acid	g/l	0.4232	1.2334	1.0757	0.9871	1.2406	0.7756
Fumaric acid	mg/l	-	1.1	0.7	0.6	1.0	1.1

Table 3. Color characteristics of honey wine *

Parameter	Honey must	SafCEnoTM VR-44	SafCider AB-1	SafCider AS-2	SafCider AC-4	SafCider TF-6
Absorption coefficient						
A420 Yellow	0.33	0.4027	0.218	0.2145	0.2201	0.2408
A520 Red	0.18	0.2444	0.1069	0.1054	0.1081	0.1258
A620 Blue	0.12	0.1793	0.0747	0.0723	0.0714	0.0714
Color intensity	0.63	0.83	0.4	0.39	0.4	0.44
Color shade	1.91	1.65	2.04	2.04	2.04	1.91
Color composition %						
A420 Yellow	53.09	48.73	54.56	54.7	55.07	54.98
A520 Red	27.81	29.57	26.74	26.87	27.06	28.71
A620 Blue	19.09	21.69	18.69	18.43	17.87	16.3

*Composed by the authors.

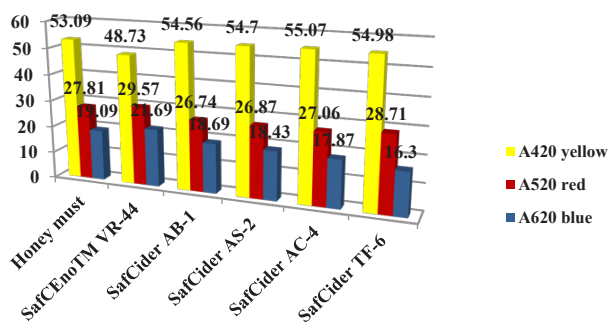

Figure 2. Color composition (%) (composed by the authors).

According to the received data, the color intensity coefficient compared to the hunger indicator decreased in all samples except for VR-44. The color intensity decreased due to exposure to other yeasts. In the case of Color Hue, the opposite picture is observed: it decreased in the case of VR-44, remained the same in the case of TF-6, and increased in the case of other yeasts.

There was also a change in color composition, the yellow shade (53.09 %) increased in AB-1, AS-2, AC-4, and TF-6 yeasts. In the case of red color, the change is small: minimum 26.87 %, maximum 29.57 %. The blue color was 19.09 % in the sample, but increased to 21.69 % in VR-44 and decreased to 6.3 in other samples.

Conclusion

Analyzing the results of the research, especially physicochemical tests it became clear that the use of the mentioned yeasts is appropriate in the production of honey wine. The main issue in our opinion is sluggish and slow fermentation, as mentioned in the literature data (Carol, et al 2006). For this reason, we made new trials to speed up the fermentation process, which will be presented in the following articles.

It is well known that for the evaluation of wine or other alcoholic beverage quality the most important thing is organoleptic tasting. Physicochemical tests are very important for controlling fermentation, aging, and another process in wine and beverage production, but till now there is not any analytical equipment that can measure human feeling when they drink good wine.

The results of the tasting of the samples will be presented in the following articles to study the organoleptic properties of the samples and we are planning to make aroma wheels for each sample which will show the specific properties of the yeasts.

References

- Al-Mamary, M., Al-Meerri, A., and Al-Habori, M. (2002). Antioxidant Activities and Total Phenolic of Different Types of Honey. *Nutrition Research*; 22(9): 1041-1047. [https://doi.org/10.1016/s0271-5317\(02\)00406-2](https://doi.org/10.1016/s0271-5317(02)00406-2).
- Antonio Iglesias, Ananias Pascoal, Altino Branco Choupina, Carlos Alfredo Carvalho, Xesús Feás, and Leticia M. Estevinho (2014). Developments in the Fermentation Process and Quality Improvement Strategies for Mead Production, Published Online, Aug 19, 19(8): 12577–12590. <https://doi.org/10.3390/molecules190812577>.
- Antonio Iglesias, Ananias Pascoal, Altino Branco Choupina, Carlos Alfredo Carvalho, Xesús Feás, ORCID and Leticia M. Estevinho (2014). Developments in the Fermentation Process and Quality Improvement Strategies for Mead Production, Department of Anatomy and Animal Production, Faculty of Veterinary Science, University of Santiago de Compostela, Lugo, Galicia E-27002, Spain. <https://doi.org/10.3390/molecules190812577>.
- Bayon, J. (1997). Mead of the Celts: A Celestial Liquor. *ArMen*.86;0-37.
- <https://fermentis.com/en/> (accessed on 01.10.2022).
- Carol, L. Wintersteen, Lia, M. Andrae, Nicki, J. Engeseth (2006). Effect of Heat Treatment on Antioxidant Capacity and Flavor Volatiles of Mead, 31 May. <https://doi.org/10.1111/j.1365-2621.2005.tb07071.x>.
- International Organisation of Vine and Wine. “Compendium of International Methods of Wine and Must Analysis”, OIV-18 RUE D’AGUESSEAU - 75008 PARIS, Edition 2022, Volume 1-2, - 1514 p.
- Jorczyk, A., Wzorek, W. (1977). Fruit and Fruit Wines. In: Rose A.H., Editor *Economic Microbiology, Alcoholic Beverages*. Volume 1 Academic Press; London, UK.

9. Kazumyan, K.N., Mikayelyan, M.N., Gevorgyan, E.R., Jraghatspanyan, A.A. (2022). Investigating the Effect of Yeasts and their Derivatives on the Qualitative Indices of Red Wine. Food Science and Technology ANAU, N2/78, -pp. 196-201. <https://doi.org/10.52276/25792822-2022.2-196>.
10. Lafon-Lafourcade, S., Geneix, C., Ribereaugayon, P. (1984). Les modalités de mise en œuvre des écorces de levure en vinification. Connaissance Vigne Vin, 2, - pp. 111-125. <https://doi.org/10.20870/oenone.1984.18.2.1755>.
11. Navrátil, M., Sturdík, E., and Gemeiner, P. (2001). Batch and Continuous Mead Production with Pectate Immobilised, Ethanol-Tolerant Yeast, Biotechnology Letters 23(12):977-982. <https://doi.org/10.1023/a:1010571208324>.
12. Ribereau-Gayon, P., Gloires, Y., Maujean, A., Dubourdiou, D. (2006). Handbook of Enology, Volume 2: The Chemistry of Wine and Stabilization and Treatments. John Wiley & Sons, - p. 442.
13. Ribereau-Gayon, P., Gloires, Y., Maujean, A., Dubourdiou, D. (2006). Handbook of Enology, Volume 1. The Microbiology of Wine and Vinifications, 2nd Edition, John Wiley & Sons, 2006, - p. 498. <https://doi.org/10.1002/0470010398>.
14. Schneider, A., Gerbi, V., Redoglia, M., Rapid, A. (1987). HPLC Method for Separation and Determination of Major Organic Acids in Grape Musts and Wines, American Journal of Enology and Viticulture, January, - Vol:38 No: 2, - pp. 151-155.
15. Victoria Moreno-Arribas, M, Carmen Polo, M. (2009). Wine Chemistry and Biochemistry. Springer Science+Business Media, LLC 2009.

Accepted on 29.10.2022
Reviewed on 30.11.2022



UDC 637.525

The Effect of *Aspergillus Niger* Fungus on the Development of Fungus Defect in Matured Raw Meat

A.L. Dashtoyan, S.Z. Nazaryan*Armenian National Agrarian University*annad-1976@mail.ru, nazaryan.s@list.ru

ARTICLE INFO

Keywords:

*beef,
defect,
fungi/yeast,
preservation,
microbiological examination*

ABSTRACT

Meat is a source of complete proteins of animal origin, which is necessary for the construction of human body tissues, synthesis and exchange of substances. In the RA, serious attention is paid to obtaining meat raw materials, sanitary and hygienic requirements and storage. However, even a high level of control does not allow consumers to be protected from the presence of low-quality and defective meat raw materials at consumption points. Sometimes they occur in meat raw materials of non-slaughterhouse origin, sometimes as a result of violating the rules of storage and transportation. The purpose of the work is to select and separate defective beef raw materials and to find out the defect causes.

Introduction

Raw meat makes up 60-70 % of the diet of the population in the Republic of Armenia and it is also of strategic importance. Today, in our country, attention is paid to obtaining meat raw materials, sanitary-hygienic requirements and storage. Meat is a source of complete proteins of animal origin, which is necessary for the construction of human body tissues, synthesis and exchange of substances, it is also a source of phosphorus (www.fitaudit.ru). Nutrients present in meat take part in the physiological functions of nervous tissues, fats, vitamins of group B, microelements. Beef consists of protein, carbohydrates, fat, water, enzymes, vitamins, extractive substances (Hambardzumyan, et al.,).

Meat belongs to the category of perishable foods,

therefore, when stored in unfavorable conditions, undesirable changes may occur in it. Some of them are caused by physicochemical factors, others are the result of the biological activity of microbes. The speed, nature and depth of such changes depend on a number of factors:

1. Pre-slaughter state of the animal
2. Sanitary and hygienic condition of meat processing and storage
3. Nature of microbial flora, etc. (Irkítova, 2017).

The meat mold process depends on the degree of accumulation of mold spores on the surface of the raw meat. Contamination of meat with mold can occur from air, refrigerators, during violation of storage and transportation conditions. Fungi are aerobic; therefore,

they develop more often on the surface of meat. Fungi can develop in an acidic environment ($pH=5.0-6.0$), relatively low air humidity, low temperature and lack of ventilation.

Some mold species grow at 1-2 °C, even below 0. Fungi develop more slowly, so their development occurs during long-term storage of meat (Krasnikova, 2016).

Molding is accompanied by the breakdown of proteins, formation of amino acids, deamination of the latter and the ammonia formation. In connection with that circumstance, the reaction of the meat environment shifts to the basal, which creates favorable conditions for the development of spoilage microbes (Irkutova, 2017).

Using such meat in industry causes serious difficulties for producers. In this case, sometimes excessive preliminary heat treatment is required, but it is necessary to change the compositions and thermal parameters of some technological processes, which creates an excessive burden for the manufacturer (Krasnikova, et al., 2016).

However, even a high control level does not allow avoiding the presence of low-quality and defective meat raw materials at the points of consumption. Sometimes they occur in meat raw materials of non-slaughterhouse origin, sometimes as a result of violating the rules of storage and transportation (Borodina, et al., 1980).

Materials and methods

As a result of the raw meat market investigation, we faced some simple problems, namely the presence of defective meat at the points of consumption, processing of defective meat, presentation of defective meat instead of fresh, without predicting the consequences. Therefore, there was a demand to study meat defects in the market, to explain their causes and to develop measures to eliminate or prevent them. As a result of the surveys, it became clear that the majority of consumers buy and use mostly beef; so beef, regardless of its category, became the object of the current work. The purpose of this work is to select and identify defective beef raw materials from consumer points (market, supermarkets) and carry out laboratory research to find out the causes of defects. To this end it was determined to conduct the following investigations:

- chemical composition, properties and pH of raw meat, particularly beef
- microbiological indicators of meat raw materials
- identifying defect type
- investigating sensory, physicochemical and microbiological indicators of defective raw meat

- developing the ways of defect elimination.

The pH of beef (category I), content of fungi/yeasts, particularly *Aspergillus niger*, which develop mainly in the folded parts of the meat surface and in an airless environment, were studied. Sampling was carried out from different points of consumption: two samples from the market, two samples from supermarkets. To perform the experiments the sampled meat raw material was kept at 0-4 °C for 24 hours.

Microbiological studies of the samples were carried out in the laboratory of the Faculty of Biology of Yerevan State University, while physicochemical studies and pH determination were carried out in the laboratory of the Chair of Animal-Based Food Products Processing Technology of the Armenian National Agrarian University. The experiments were performed in triplicate, and the arithmetic mean value was taken as the result. It should be noted that the research of the samples was carried out with meat tenderloin on 1, 3, 5 days of storage.

In order to determine the amount of fungi, samples were prepared and kept in a thermostat for 5 days at 37 °C, which is a favorable environment for the rapid growth of fungi, then the CFU of fungi, particularly *Aspergillus niger*, were calculated (GOST 54354-2011, GOST 21237 -75).

Results and discussions

Determination of chemical composition of beef was carried out in accordance with MM TC 034. As it was mentioned, the category I beef samples from the market (Sample I, II) and supermarket (Sample III, IV) were tested and the results are recorded in Table 1.

Table 1. Chemical composition of beef*

Category I beef	In 100 grams of the product			
	Water, %	Proteins, %	Fats, %	Ash, %
Sample I	64.5	18.6	16.0	0.9
Sample II	64.8	17.9	16.5	0.8
Sample III	65.7	18.4	15.0	0.9
Sample IV	66.1	17.6	15.4	0.9

*Composed by the authors.

As can be seen from the results of Table 1, the sampled meats have almost the same chemical composition, which means that the changes taking place in them can be basically the same. Determination of the pH in the folded part of the samples will reveal the degree of the raw meat maturation. For this purpose, the samples were kept at 0-4 °C for 1, 3, 5 days. The average numerical values of the performed studies are presented in Table 2.

Table 2. pH indicators in the folded part of tested samples*

Sample number	Ph
Sample I / day 1 /	6.3
Sample II /day 3 /	6.0
Sample III /day 5 /	5.8

*Composed by the authors.

As the results of Table 2 show, during the storage period of 1, 3, 5 days, there are changes in the meat pH, in a decreasing order (Figure). Such a change occurs as a result of the breakdown of glycogen during storage, when lactic acid accumulates, as a result of which the pH index decreases (Velichko and Mashanov, 2019). This is a normal process of meat maturation, but depending on the storage conditions, microbiological changes, particularly fungal ones, can damage the quality of meat raw materials and become a threat to the further meat preservation (Antipova and Zherebtsov, 1991).

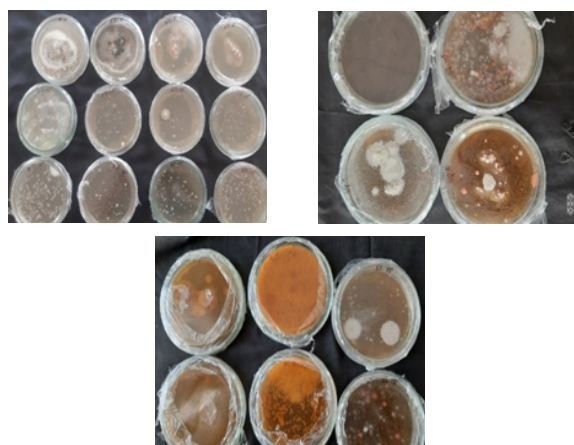

Figure. Samples on the days of 1, 3 and 5.

Table 3. Determination of the fungi/mold amount in the folded part of raw meat*

Sample number	Aspergillus niger CFU/gram
Sample I /Day 1 /	2.4 x 10 ⁴
Sample II /Day 3 /	2.5 x 10 ⁴
Sample III /Day 5 /	7.8 x 10 ⁴

*Composed by the authors.

The analysis of Table 3 shows that the meat storage conditions have a rather serious effect on the microbiological indicators, because after 5 days of storage, the amount of fungi in the folded area increases and reaches 7.8 x 10⁴ CFU/g. As we know, frozen beef reaches its best taste and quality indicators during storage at 0-4 °C for 5-10 days, but it is important to maintain all storage parameters: relative air humidity, movement speed and temperature (Velichko and Mashanov, 2019). Under these conditions, the meat raw material keeps its original properties and becomes a high-quality raw material for meat processors. The analysis of the table enables to state that it is not possible to provide such storage conditions in household refrigerators at home, as a result, meat raw materials become not only of poor quality, but can also be a source of growth and development for various types of fungi, making meat raw materials unsafe for consumption.

Conclusion

In order to obtain safe and high-quality meat raw materials, it is necessary to control not only the receipt of meat raw materials in slaughterhouses, but also its preservation, ensuring clear conditions for cold storage.

Summing up the scientific work, we can draw the following conclusions:

- Meat sampling was conducted and the chemical composition depending on its type was studied.
- Changes in the pH of raw meat during storage were determined and it was substantiated that the pH changes in raw meat during storage, even in folded parts, proceed according to the regular principles, in descending order.
- The growth of *Aspergillus niger* fungi in the folded part of raw meat during storage was determined during 1, 3, 5 days of storage.

- It was found out that in the folded parts of raw meat, even in case of acidic range of the pH index, the mold defect occurs, this can be proved by the high amount of *Aspergillus niger* fungus – 7.8×10^4 CFU/g.

The correct storage of raw meat has been known for a rather long time and despite this, we still encounter various raw meat defects in markets and supermarkets. Based on the above, we suggest organizing a strict control of the storage conditions, depending on the heat treatment, the correct arrangement of the meat, in order to exclude the occurrence of possible defects.

References

1. Antipova, L.V., Zherebtsov, N.A. (1991). "Biochemistry of Meat and Meat Products", Voronezh, - 246 p. (in Russian).
2. Borodina, Z.V., Grimm, A.I., Danilov, M.M. (1980). Research on Food Products. Economy, - 272 p.
3. GOST 21237-75. Meat. Methods of Bacteriological Analysis.
4. GOST R 54354-2011. Meat and Meat Products. General Requirements and Methods of Microbiological Analysis.
5. Hambardzumyan, V., Harutyunyan, Zh., Khachatryan, N. (2008). Food Expertise, Yerevan, - 127 p. (in Armenian).
6. <http://www.fitaudit.ru/food/167937>. FitAudit (accessed on 18.10.2022).
7. Irkitova, A. N. (2017). Microbiology of Products of Animal Origin. Manual / A. N. Irkitova; AltGU. - Barnaul, - 152 p.
8. Krasnikova, L.V. (2016). Microbiology of Products of Animal Origin. Manual / Krasnikova L.V. — Saint-Petersburg: Trinity Bridge, — 296 p.
9. Technical Regulation of EAEU Customs Union 034. "On the Safety of Meat and Meat Products".
10. Velichko, N.A., Mashanov, A.I. (2019). "Technology of Meat and Meat Products" - Krasnoyarsk, - 345 p.

Accepted on 02.11.2022
Reviewed on 29.11.2022



UDC 663.32:663.326(479.25)

Investigation of the Possibility of Cider Production in Armenia Using Different Dry Active Yeasts

A.Kh. Iskandaryan, M.N. Mikaelyan, E.R. Gevorgyan*Armenian National Agrarian University*amaliiskandar@gmail.com, mikayelyan.m@mail.ru, elyanora.gevorgyan@mail.ru

ARTICLE INFO

Keywords:

*cider,
active dry yeast,
low alcoholic beverages,
physicochemical composition of
cider,
organic acids*

ABSTRACT

The volume of production and consumption of cider as a low alcoholic and soft drink is increasing year by year. Being a part of the global economy, a similar trend is also noticeable among a smaller scale Armenian producers and consumers. During this research we studied the physicochemical parameters of apple juice and ready-made cider obtained from apple varieties common in Armenia. Fermentation was carried out with four different yeasts intended for cider production and one control sample. The aim was to reveal the effect of each yeast on the quantitative and qualitative characteristics of the final cider.

Introduction

These research activities were carried out with the support of Innovative Agriculture Training and Learning Camp (AGRI CAMP) Program which is financed by the United States Agency for International Development (USAID) and implemented by International Center for Agribusiness Research and Education Foundation (ICARE).

The contents are the responsibility of author/s and do not necessarily reflect the views of USAID or the United States Government.

The climatic conditions of the Republic of Armenia are favorable for growing different types of fruits. Apple cultivation is widespread in Armenia, it is cultivated almost in all regions of the republic. In recent years, an average of 100 000 tons of fresh apples have been produced in Armenia (Statistical Committee of the Republic of

Armenia), most of which have been consumed as fresh fruit without processing, and the rest – as raw materials for the production of juices and alcoholic beverages, such as cider and fruit distillates, Calvados.

Cider is known by different names in the world, it can differ in alcohol and sugar content, as well as in production method depending on the country of production (Kosseva, et al., 2017). Being a weak alcoholic and soft drink, the volume of production and consumption of cider is increasing every year (Cider Market Report, 2019-2025). This trend is also noticeable in Armenia, although the volumes are still small.

The purpose of this research was to study the cider production technology from apple varieties common in Armenia, specifically using four different yeasts intended for cider production.

In one of the numerous studies carried out worldwide, non-Saccharomyces yeast strains, combined and uncombined, used for the production of low-alcohol beer, have also shown good results for the production of new types of more aromatic beverages (Madrera, et al., 2021). However, Saccharomyces yeasts strains still occupy a leading position in the fermentation process of the production of various alcoholic beverages due to their efficiency and aromatic characteristics.

To carry out our research, four strains of active dry yeast for the production of cider of the Lesaffre Group French company Fermentis brand were selected. The choice of yeast strains is not accidental, as studies carried out by the producer have shown that the yeast strains can have an important effect not only in terms of the analysis of fermentation dynamics, but also in terms of cider sensory perception. They can be viewed as a powerful tool to diversify the cider offered in the market, and cider makers can produce a distinctive drink using the same raw materials.

Materials and methods

Apple juice from the most common apple varieties grown in Armenia – Golden Delicious, Renet Simirenko and Aйдored was used for the research.

For the fermentation, four types of dry active yeasts were used: SAFCIDER™ AB-1, SAFCIDER™ AS-2, SAFCIDER™ AC-4, SAFCIDER™ TF-6. As for cider production in Armenia it is common to use a yeast made for beer production, while SAFALE™ S-04 beer yeast was used as a control sample.

The study of the physicochemical composition of apple juice samples was carried out using the methods accepted in enochemistry, in accordance with the standards developed by the OIV (International Organization of Grapes and Wine) and GOSTs in force in RA, as well as with other experimental methods.

Apple juice provided by Yerevan Beer Factory was poured into glass fermentation containers prepared for five samples. Potassium metabisulphite at 50 mg/l was added to the samples to suppress the possible life activity of undesirable microorganisms. One of the five types of yeasts was added to each of the apple juice sample, according to the manufacturer's recommended dosage, and subjected to fermentation. Fermentation was carried out in glass containers, which were sealed with airlock lids. Fermentation was carried out at a temperature of 18-20 °C under conditions recommended by the producer. The entire process of fermentation was

monitored. After the completion of fermentation, the fermented samples were decanted from the sediment. A study of the chemical composition of one control cider (sample: S-04) and four types of ciders obtained (sample: AB-1, AS-2, AC-4, TF-6) was carried out according to the above mentioned methods. Potassium metabisulphite at 50 mg/l was added to the fermented cider samples, and they were transferred to the refrigerator and stored at +2-+4 °C temperature conditions. In three months the samples were decanted from the sediment. The samples separated from the sediment were kept for a week at room temperature and then potassium metabisulphite was added at a dose of 50 mg/L. A small part of the samples was degusted on the spot and the rest of the samples was transferred to the refrigerator to be degusted after aging.

The study of the physicochemical indicators of the apple juice and ciders include the following analyses (indicating the appropriate methods of study): total acidity (OIV-MA-AS313-01), pH-active acidity, sugars (measurement by refractometer), total and free sulfur dioxide (OIV-MA-F1-07), fermentable nitrogen YAN (Fracassetti, et al., 2017), total phenols (Zoecklein, et al., 1999), chromatic characteristics (OIV-MA-AS2-07B), Folin Ciocalteu index (OIV-MA-AS2-10) (International Organization of Vine and Wine, 2022). Determination of alcohol content (OIV-MA-AS312-01A), as well as determination of residual sugar, volatile acidity (OIV-MA-AS13-02), aldehydes and acetals, was also performed for cider. Organic acids were measured by HPLC (system: Agilent 1100 Series, detector: Agilent 1260 Infinity) (Schneider, et al., 1987), phenolic compounds – by photocolormetry (photocolormetric) method (Jacobson, 2006).

Results and discussions

The results of the laboratory analyses of the main physicochemical parameters of apple juice and ciders are presented in Table 1.

The acidity of the juice mixtures used for fermentation is important because it helps to control the growth of undesirable microbes. The active acidity index of juice pH partly determines the antibacterial and antioxidant capacity of sulfites to inhibit the growth of wild microflora and yeasts, and as juice pH increases, more quantity of free SO₂ is required (Beech, 1972). Sulfur dioxide inhibits wild yeast growth and allows Saccharomyces strains (which are more resistant to SO₂ than wild yeasts and most potentially spoilage microorganisms) to thrive and dominate fermentation (Jarvis & Lea, 2000). In addition to its antimicrobial effects, SO₂ is a powerful antioxidant that

can prevent juice oxidation and browning. However, SO₂ is only effective in its free or unbound form. In our study, despite the relatively high content of sulfur dioxide, the yeasts added to the apple juice were fully functional and they completed the fermentation (Table 1).

The final pH and total acidity of the cider play an important role in the stabilization and shelf life of the bottled product. Low acidity (pH > 3.8) can lead to growth of microorganisms spoilage and bad odors (Lea & Drilleau, 2003). Final acidity also has a big impact on the flavor profile of a cider; high acidity can impart harshness to the cider, which usually requires the addition of some amount of sugar to balance the cider's flavor. As we can see in Table 1, the total acidity of apple juice is 2.75 g/l and the pH is 3.39, in the case of AS-2 yeast, the total acidity increased the most, reaching 3.71 g/l, and the pH – 3.28, respectively. In the case of AC-4 and TF-6 yeasts, total acidity increased by the same amount, reaching 3.58 g/l, and pH – 3.36, in the case of S-04, the amount of total acids increased by a relatively smaller amount, reaching 3.39 g/l, and the pH – 3.38, in the case of AB-1, the amount of total acids remained the same – 2.75 g/l, and the pH, unlike the other samples, increased to 3.53. The indicators of volatile acidity of fermented ciders are within acceptable limits (Table 1). The lowest amount of volatile acidity in cider was obtained with S-04

yeast – 0.19 g/l, then TF-6 – 0.21 g/l, AS-2 – 0.25 g/l, AB-1 – 0.30 g/l, and the highest was in the case of AC-4 – 0.35 g/l.

Apple juice contains a variety of plant secondary metabolites that include an aromatic ring and at least one hydroxyl group and are commonly referred to as phenolics or tannins (Shi, et al., 2003). Polyphenolic compounds in plants act as defense mechanisms against insects, bacteria and fungi. Secondary metabolite concentrations in fruit are influenced by many factors, such as light, temperature and other growth regulators, including terroir. Polyphenolic compounds are broken down by oxidation, which occurs mainly due to contact with air during grinding or crushing of apples, in the presence of the enzyme polyphenoloxidase. Apple pressing and juice fermentation methods for cider can also affect final phenolic concentrations in bottled products (Merwin, et al., 2008). Folin Ciocalteu Index (FCh-I) is a popular international method for measuring the total content of phenolic substances in food. Laboratory analyses performed during our research show that the total content of phenolic substances in apple juice was 696.05 mg/l, and the Folin Ciocalteu index (FCh-I) was 15.82. During fermentation, the amount of the phenolic compounds decreased (Table 1). The total content of phenolic compound is the highest in the S-04 cider sample, 576.71 mg/l, and Folin Ciocalteu index (FCh-I) is 13.10.

Table 1. Results of laboratory analyses of some physicochemical parameters in the studied apple juice and ciders*

Parameters	Unit	Apple juice	Cider S-04	Cider AB-1	Cider AS-2	Cider AC-4	Cider TF-6
Alcohol	Vol.%	-	7.00	7.40	7.20	7.50	7.20
Total acidity	g/l	2.75	3.39	2.75	3.71	3.58	3.58
pH	-	3.39	3.38	3.53	3.28	3.36	3.36
Volatile acidity	g/l	-	0.19	0.30	0.25	0.35	0.21
Sugar	g/l	130	1.47	1.09	1.09	0.93	1.16
Free Sulfur dioxide	mg/l	50.59	3.72	2.79	3.72	3.10	3.41
Total Sulfur dioxide	mg/l	110.01	59.29	55.87	52.46	46.87	63.32
Reductones Sulfur dioxide	mg/l	2.54	2.48	2.48	2.48	2.17	3.10
Yeast Assimilable Nitrogen (YAN)	mg/l	244.72	33.60	39.20	33.60	33.60	30.80
Folin Ciocalteu Index (FCh-I)	-	15.82	13.10	11.82	12.63	12.16	12.69
Total Phenols	mg/l	696.05	576.71	520.22	555.78	535.43	558.55
Aldehydes	mg/l	-	32.56	40.04	57.20	36.08	28.60
Acetals	mg/l	-	17.70	50.74	20.06	12.98	18.88

*Composed by the authors.

In AS-2 and TF-6 cider samples, the indicators are almost the same: 555.78 mg/l, FCh-I: 12.63 and 558.55 mg/l, FCh-I: 12.69. AC-4 cider sample: 535.43 mg/l, FCh-I: 12.16, and AB-1 cider sample: 520.22 mg/l, FCh-I: 11.82.

It is desirable that the sugar content of the apple juice intended for fermentation is not higher than 140 g/l to make cider with alcohol content close to 7.00 vol. % as a result (Berry & Slaughter, 2003). The sugar content of the apple juice of our study was 130 g/l (Table 1), and as a result of its fermentation, the highest amount of alcohol was obtained in the case of AC-4 yeast – 7.5 vol. %, and the lowest amount in the case of S-04 – 7.00 vol. %. In the case of AB-1 yeast, the amount of alcohol was 7.40 vol. %, in the case of AS-2 and TF-6 – 7.20 vol. % (Table 1). The content of residual sugar did not exceed 1.5 g/l in any sample (Table 1).

The amount of yeast assimilable nitrogen (YAN) in apple juice can vary greatly depending on the apple variety (Technical Overview on Cider Production, 2018). The content of YAN in the apple juice of our study was 244.72 mg/l (Table 1), and as the YAN (mg/l)/Sugar (g/l) ratio is equal to 1.88, that is, it is higher than the instructions provided by the company that produces the yeast, no additional nutrients were given during fermentation. During fermentation nitrogen consumptions were in full accordance with the manufacturer's instructions. TF-6 consumed the most, leaving a residue of 30.80 mg/l, samples S-04, AS-2 and AC-4 had the same consumption of fermentable nitrogen, leaving a residue of 33.60 mg/l, and sample AB-1 had the least consumption, leaving 39.20 mg/l residue.

Aldehydes are produced as a result of the non-enzymatic process of oxidative-deamination of amino acids (alanine) and in the Krebs cycle. In small concentrations, they have a pleasant smell and participate in the formation of special aromas (Kazumyan, et al., 2022). The quantity of aldehydes in our examined samples was: S-04 – 32.56 mg/l, AB-1 –

40.04 mg/l, AS-2 – 57.20 mg/l, AC-4 – 36.08 mg/l, TF-6 – 28.60 mg/l (Table 1). Acetals have a direct, positively significant correlation with methanol, ethers and aromatic acids. The addition of acetals during fermentation increases their presence in the wine. The quantity of acetals in our samples was 17.70 mg/l in S-04, 50.74 mg/l in AB-1, 20.06 mg/l in AS-2, 12.98 mg/l in AC-4 and in TF-6 – 18.88 mg/dm³ (Table 1).

The color characteristics of the samples were measured with a UNICO 2802 UV/VIS photoelectric colorimeter at 420, 520, and 620 nm (International Organization of Vine and Wine, 2021). As a result, the color intensity of the apple juice was 1.72, and the color intensity of the cider samples in descending order was: AS-2 – 0.39, TF-6 – 0.34, S-04 – 0.34, AB-1 – 0.32, AC-4 – 0.32. In apple juice, the color shade is 2.22, and in the cider samples, the highest color shade is as follows: AB-1 – 3.84, AC-4 – 3.55, AS-2 – 3.31, TF-6 – 3.16, S-04 – 3.13.

Color characteristics are made up by combining three colors measured respectively – at 420 nm: yellow, 520 nm: red, and 620 nm: blue (Table 2). The percentage ratio of color characteristics in the investigated apple juice and cider samples is presented in Diagram.

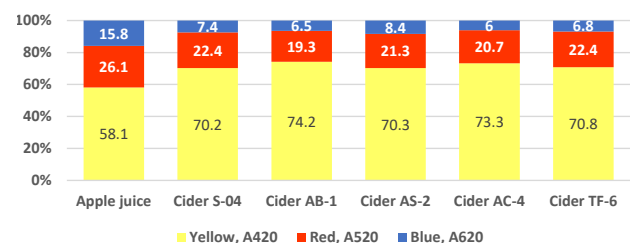

Diagram. Color characteristics of the studied apple juice and ciders, % (composed by the authors).

Table 2. Color characteristics of the studied apple juice and ciders*

Parameters	Apple juice	Cider S-04	Cider AB-1	Cider AS-2	Cider AC-4	Cider TF-6
Yellow, A420	0.9984	0.2390	0.2375	0.2757	0.2355	0.2410
Red, A520	0.4498	0.0764	0.0618	0.0834	0.0663	0.0763
Blue, A620	0.2722	0.0249	0.0206	0.0330	0.0194	0.0230
Color intensity	1.72	0.34	0.32	0.39	0.32	0.34
Color shade	2.22	3.13	3.84	3.31	3.55	3.16

*Composed by the authors.

Table 3. Results of laboratory analyses of organic acids in the studied apple juice and ciders*

Parameters	Unit	Apple juice	Cider S-04	Cider AB-1	Cider AS-2	Cider AC-4	Cider TF-6
Malic acid	g/l	4.11	3.38	2.69	3.77	3.87	3.51
Lactic acid	g/l	0.05	0.43	0.17	0.17	0.2	0.31
Tartaric acid	g/l	-	-	-	-	-	-
Formic acid	g/l	0.14	0.31	0.26	0.17	0.22	0.31
Ascorbic acid	g/l	-	-	-	-	-	-
Shikimic acid	mg/l	8.60	14.10	9.60	11.40	11.60	20.00
Acetic acid	g/l	-	0.26	0.34	0.31	0.31	0.33
Citric acid	g/l	0.30	0.61	0.43	0.74	0.83	0.64
Succinic acid	g/l	0.16	0.57	0.45	0.38	0.48	0.55
Fumaric acid	mg/l	1.10	3.00	7.20	10.80	6.10	2.40

*Composed by the authors.

Apart from water, the main components of cider are organic acids, sugars, alcohols and polyphenolic compounds. The main organic acid present in apples is malic acid (Merwin, et al., 2008). The amount of malic acid in our apple juice sample was 4.82 mg/l. Depending on the characteristics of the yeast, malic acid decreased in different amounts during fermentation, and in some cases, new formations in the form of other organic acids appeared (Table 3).

Organic acid concentrations were tested in apple juice and all cider samples. The result shows the presence of malic acid in the juice – 4.11 g/l and in all samples in the range of 2.69 g/l – 3.87 g/l. From the results we can conclude that malolactic fermentation has occurred in all the samples. Acetic acid concentration is equivalent within the range of volatile acid values. The citric acid content in the juice is 0.30g/l, but in all cider samples it has increased in the range of 0.43-0.83 g/l. The highest concentration of citric acid was identified in the AC-4 sample – 0.83 g /l, it has been increased 2.7 times compared with the juice. In the Krebs Cycle, citric acid is formed through several derivatives, which are converted into succinic acid. Succinic acid was detected in all studied samples. The highest concentration of succinic acid was identified in S-04 sample – 0.57 g /l. The Krebs Cycle ends with dehydrogenation to fumaric acid. Fumaric acid was detected only in a very little amount in the range of 2.40 – 10.80 mg/l. Shikimic acid is an indispensable intermediate product in the biosynthesis of aromatic compounds (Kazumyan, et al., 2022). Shikimic acid was detected in all the samples in the range of 9.60-20.00 mg/l. The highest concentration of shikimic acid was identified in TF-6 sample – 20 mg/l. The role of the organic acids is important for the freshness in the mouth, balance of cider taste and aroma bouquets.

Conclusion

The results of this research allow us to conclude that the selected four different yeasts are favorable and effective for apple juice fermentation and cider production. The choice of yeasts depends on the initial chemical content of the apple juice and the expected final flavor profile of the cider. According to the results of the research, it is advisable to use S-04 yeast for cider production with a relatively low alcohol and acidity content, and to use AS-2 yeast for cider with medium alcohol content and relatively high acidity. Compared with the control sample, ciders produced with all the other yeasts increased content of total acidity, except for AB-1, which didn't have any impact on the acidity of the cider. Although the indicators of volatile acidity of fermented ciders are within acceptable limits, their concentration in all the other samples was slightly higher compared with the control sample. The content of phenolic substances was slightly inferior to that of the control sample, but the content of aldehydes was predominant in the AB-1 sample and the content of acetals was predominant in the AS-2 sample. In terms of color characteristics, the content of yellow color prevailed in all samples compared to apple juice. The sample with the highest color intensity was AS-2, and the most expressive color shade was observed in the AB-1 sample. All yeasts contributed to the formation of organic acids during their metabolism, but they were manifested in different ways in terms of the amounts of the produced organic acids. It is planned to carry out a sensory evaluation with the samples matured on the above-mentioned cider yeast sediment, with the method of characterization through tasting. Based on the tasting results, aroma wheels will be created for each sample yeast to help characterize the yeast and understand which yeast produces the best sensory performance.

References

1. Beech, F.W. (1972). Cider Making and Cider Research: A Review. *J. Inst. Brew.* 78:477–491. <https://doi.org/10.1002/j.2050-0416.1972.tb03485.x>.
2. Berry, D.R., and Slaughter, J.C. (2003). Alcoholic Beverage Fermentations, In A.G.H. Lea and J.R. Piggot (eds.), *Fermented Beverage Production*. Kluwer Academic/Plenum Publ., New York, - p. 423. https://doi.org/10.1007/978-1-4615-0187-9_2.
3. Bruce, W. Zoecklein, Kenneth, C. Fugelsang, Barry, H. Gump, Fred, S. Nury (1999). *Wine Analysis and Production*, by Aspen Publishers, Inc., - 621 p. <https://doi.org/10.1007/978-1-4757-6967-8>.
4. Cider Market Size, Share & Trends | Industry Growth Report, 2019-2025 (grandviewresearch.com), <https://www.statista.com/>.
5. Daniela Fracassetti, Mario Gabrielli, Onofrio Corona, Antonio Tirelli (2017). Characterization of Vernaccia Nera (*Vitis vinifera* L.) Grape and Wine, *South African Journal of Enology & Viticulture*, Vol. 38, No. 1, - pp. 78-81. <https://doi.org/10.21548/38-1-867>.
6. Exploring Diversity of Cider Profiles through the Selection of New Yeast Strains - Fermentis. Available at: <https://fermentis.com/en/knowledge-center/expert-insights/cider/exploring-cider-profiles/> (accessed on 14.09.2022).
7. International Organisation of Vine and Wine, “Compendium of International Methods of Wine and Must Analysis”, OIV-35 RUE DE MONCEAU, 75008 PARIS, Edition 2022, Volume 1, - 607 p.
8. Jacobson, Jean L. (2006). *Introduction to Wine Laboratory Practices and Procedures*, United States of America, Springer Science + Business Media, Inc., - 375 p.
9. Jarvis, B., and Lea, A.G.H. (2000). Sulphite Binding in Ciders. *Int. J. Food Sci. Technol.* 35:113–127. <https://doi.org/10.1046/j.1365-2621.2000.00370.x>.
10. Kazumyan, K.N., Mikaelyan, M.N., Gevorgyan, E.R., Jraghatspanyan, A.A. (2022). Investigating the Effect of Yeasts and their Derivatives on the Qualitative Indices of Red Wine // *Agriscience and Technology*, ANAU, - N2/78, pp. 196-201. <https://doi.org/10.52276/25792822-2022.2-196>.
11. Kosseva, M. R., Joshi, V.K., and Panesar, P.S. (2017). *Science and Technology of Fruit Wine Production*, Elsevier Inc, - 727p. <https://doi.org/10.1016/b978-0-12-800850-8.05001-8>.
12. Lea, A.G.H., and Drilleau, J.F. (2003). Cidermaking, In: A.G.H. Lea and J.R. Piggot (eds.). *Fermented Beverage Production*. Blackie Academic, London, - pp. 66–96. https://doi.org/10.1007/978-1-4615-0187-9_4.
13. Merwin, Ian & Valois, Sarah & Padilla-Zakour, Olga (2008). Cider Apples and Cider-Making Techniques in Europe and North America. *Horticultural Reviews*. <https://doi.org/10.1002/9780470380147.ch6>.
14. Rodríguez Madrera, R., Pando Bedriñana, R. & Suárez Valles, B. (2021). Evaluation of Indigenous Non-Saccharomyces Cider Yeasts for Use in Brewing. *Eur Food Res Technol* 247, - pp. 819–828. <https://doi.org/10.1007/s00217-020-03665-y>.
15. Schneider, A., Gerbi, V., Redoglia, M., Rapid, A. (1987). HPLC Method for Separation and Determination of Major Organic Acids in Grape Musts and Wines, *American Journal of Enology and Viticulture*, Vol. 38, - No 2, - pp. 151-155.
16. Shi, J., Yu, J., Pohorly, J., and Kakuda, Y. (2003). Polyphenolics in Grape Seeds-Biochemistry and Functionality. *J. Med. Food.* 6:291–299. <https://doi.org/10.1089/109662003772519831>.
17. Statistical Committee of the Republic of Armenia (2019). Availability of Food, National Food Balance of the Republic of Armenia (armstat.am), - pp. 69-75.
18. Technical Overview on Cider Production (2018). *Proceedings of the XXVIIes entretiens scientifiques Lallemand Inc.* Montréal, Library and Archives Canada.

Accepted on 29.10.2022

Reviewed on 29.11.2022

Journal homepage: anau.am/scientific-journaldoi: [10.52276/25792822-2022.4-428](https://doi.org/10.52276/25792822-2022.4-428)

UDC 619+664

Assessing Dietary Exposure of Potentially Toxic Elements via Fish Consumption

D.A. Pipoyan, V.I. Chirkova, M.R. Beglaryan, S.A. Stepanyan*Center for Ecological-Noosphere Studies NAS RA*david.pipoyan@cens.am, victoria.chirkova@cens.am, meline.beglaryan@cens.am, seda.stepanyan@cens.am

ARTICLE INFO

Keywords:

*copper,
arsenic,
fish,
food contamination,
risk assessment*

ABSTRACT

This study aims to assess the consumer health risk caused by metals in fish produced in Armenia. The collected fish samples were analyzed for copper, lead, molybdenum, and arsenic via the atomic-absorption spectrometry (AAS) method. Clusters of consumers were created after conducting public surveys and analyzing data. Risk assessment was done based on the Margin of Exposure (MOE). The results indicated that the consumer health risk is within allowable limits. Moreover, the study identified factors that influence the toxicity level of the product, pointing to a necessity for a more comprehensive approach to risk assessment.

Introduction

Food safety is a worldwide challenge significantly affecting trade and public health. Thus, countries need to implement effective food control systems to prevent food safety hazards and protect the population (WHO, 2022). Generally, surveillance programs are being conducted to assess the levels of various chemical hazards (e.g., potentially toxic trace elements) in consumed products to guarantee their conformity to national and international food safety requirements. The annual residue monitoring program currently being implemented in Armenia includes the detection of potentially toxic element contents in foods of animal origin. In 2019, in the frame of the monitoring program, fish samples were analyzed for four potentially toxic trace elements (PTEs): copper (*Cu*), molybdenum (*Mo*), lead (*Pb*), and arsenic (*As*). Among the studied PTEs, Mo and Pb were not detected (i.e., concentrations

were below the LOD-limit of detection), meanwhile concentrations detected for *As* and *Cu* were reported.

In the Middle Ages, *As* was known as “the king of poisons” (Gupta, et al., 2017). This element has a toxic effect on living organisms and is included by the WHO in the list of 10 problematic and hazardous chemical elements (WHO, 2018).

The major sources of *As* exposure for humans are water and food. Plants take up *As* from soil, productive animals – from water and feed and particularly fish flour. Seafood build up significant amounts of *As*, some 90-95 % of which belongs to organic *As* (Berntssen, et al., 2021, Pei, et al., 2019). However, there are some exceptions: hijiki algae may contain up to 60 % of inorganic *As* (EFSA, 2009, Camurati and Salomone, 2020). Besides being highly toxic, inorganic *As* also has carcinogenic properties.

The compounds of inorganic arsenic pose no hazard but are recognized as potentially carcinogenic. (Berntssen, et al., 2021, EFSA, 2009, Camurati and Salomone, 2020).

Chronic exposure to *As* may cause skin lesions, neurotoxicity, anemia, diabetes, cancer (Berntssen, et al., 2021, IARC, 2004). Arsenic is also able to traverse placental barrier (Berntssen, et al., 2021, EFSA, 2009) and thus produce fetal malformations. Acute intoxication causes vomiting, diarrhea, convulsions, ataxia, in severe cases-lethal outcomes (IARC, 2004, Gupta, et al., 2021, Zhong, et al., 2019). A lethal dose of *As* for adults is estimated as 120-200 mg, for kids is 2 mg/kg (Jain and Chandramani, 2018).

Copper is an essential micro element, its presence in the organism supports the normal functioning of enzymes and systems of organs (Rehman, et al., 2018). Sixty-five percent of this element in the diet comes from marine food, cereals, potato and liver (CAC, 2016). Insufficient intake of *Cu* leads to its deficiency in the organism characterized by flabbiness of skin, muscle weakness, neurogenic symptoms, elevated risk of cardiovascular diseases (EFSA, 2015). Excessive *Cu* exposure also has a negative effect (Kim, et al., 2019). It can cause ictericity of mucous membrane, reproductive dysfunctions, hemoglobinuria, and apathy (Gupta, et al., 2021, CAC, 2016, Kim, et al., 2019). Since copper homeostasis is associated with other elements, its disturbance may be secondary, for instance, due to excess of zinc or deficiency of *Mo* (Gupta, et al., 2021, EFSA, 2015).

Mammals are known to have different mechanisms of *Cu* homeostasis; this element is easily excreted from the organism. In most cases, an excess or a deficiency of *Cu* is observed during genetic disturbances influencing *Cu* regulation or under specific conditions: pregnancy, physical loads, stress (Gupta, et al., 2021, EFSA, 2015, Kim, et al., 2019, Burkhead and Collins, 2022, Malhotra, et al., 2020). The lethal effect in adults occurs at a per oral dose of *Cu* 200 mg/kg (CAC, 2016).

Based on the aforementioned information, it's clear that both PTEs can have adverse effects on human health. Whether an element in food will harm the organism or not depends on a certain element and its daily intake (Nepovimova and Kuca, 2019). Hence, this study aims to assess the consumer health risk caused by two PTEs (*As* and *Cu*) in fish produced in Armenia.

Materials and methods

Sampling

Fish sampling was done on November 7th to 28th, 2019.

In total, 8 fish composite samples were taken from artificial ponds run by local fish producers. This campaign is part of an annual program on monitoring residual substances in foods. Eight fish samples were tested for *Cu*, *Mo* and *Pb*, 7 out of 8 – for *As*. The sampled fish specimens belonged to the Cyprinidae, Salmonidae, Acipenseridae families.

Fish consumption

Fish consumption data were taken from the food consumption database formed using Food Frequency Questionnaire (FFQ) survey by the Informational-Analytical Center for Risk Assessment of Food Chain. Fish consumer clusters were produced after treating the data through MS Office Excel and IBM SPSS programs (Pipoyan, et al., 2020). Formation of homogenous clusters allows to assess the risk to different consumer groups more precisely, without averaging a fish consumption value.

Lab analysis

Lab work designated under this research has been done in “Republican Veterinary-Sanitary and Phytosanitary Center of Laboratory Services” SNCO. Tests were performed by the atomic-absorption spectrometry (AAS) method employing an iCE 3000 Series AA Spectrometer (Thermo Fisher Scientific, USA) in compliance with relevant normative documents (GOST R 51766-2001; GOST 30178-96). The analyzed fish samples were raw and did not undergo a culinary treatment. The samples were prepared by wet mineralization employing a Multiwave GO Microwave Digestion System (Anton Paar, USA).

Calculations. Risk assessment was done based on MOE calculations by Formula (1):

$$MOE = \frac{HBGV}{DI}, \quad (1)$$

where *HBGV* is a Health-Based Guidance Value (mg/kg body weight) of PTE, *DI* is the Daily Intake (mg/kg/day).

DI of the studied PTEs was calculated by Formula (2):

$$DI = \frac{C \times IR}{BW}, \quad (2)$$

where *C* is the mean content of PTE in a product (mg/kg); *IR* is the Ingestion Rate – the average daily intake of a product (kg/day), and *BW* is the Body Weight of a consumer. According to the FFQ, the average body weights of men and women are assumed as 74.7 kg and 59.8 kg, respectively.

The worst-case scenario

In the worst-case scenario, we assume the highest concentrations of arsenic and copper as mean concentrations in the fish samples. The average daily

intake of fish will correspond to the cluster of consumers with the highest index.

Results and discussions

Fish consumption

The fish consumer clusters were constructed based on 867 questionnaires. Previous studies regarding risk assessment of other contaminants through fish consumption also include the values of these three clusters (Pipoyan, et al., 2020).

Concentration of PTEs

The highest concentration of Cu in the sampled fish was equal to 0.587 mg/kg, the lowest – 0.208 mg/kg, the average – 0.372 mg/kg. The concentration of As varied from 0.0025 to 0.423 mg/kg, with average concentration in seven samples being equal to 0.089 mg/kg.

The average daily intake amounts of Cu and As have been calculated based on the mean concentrations of these elements for each gender and cluster group (Table 1).

Table 1. The average daily intake of PTEs via fish consumption, mg/kg/day.

Consumers	Average daily intake for men		Average daily intake for women	
	Cu	As	Cu	As
Cluster 1	7.98E-05	1.91E-05	9.97E-05	2.38E-05
Cluster 2	3.14E-04	7.51E-05	3.92E-04	9.38E-05
Cluster 3	7.78E-04	1.86E-04	9.72E-04	2.32E-04

*Composed by the authors.

For freshwater fish, the maximum allowable concentration (MAC) of arsenic is 1 mg/kg, and for saltwater fish it can be up to 5 mg/kg (TR CU 021/2011). In 2021 in Poland during the customs inspection of frozen cod imported from Russia, the detected concentration of As (11.2 mg/kg) exceeded the allowable limit more than twice (RASFF Window). In our samples the highest concentration of As does not exceed the norm, and the mean value is 11 times lower than the MAC.

Margin of Exposure (MOE)

As HBGV we employ the values derived from epidemiological investigations and observations of human responses, which excludes possible distortions as a result of different physiology and sensitivity of lab models. To

assess risks of copper intake via fish we employed the Upper Intake Level (UL). The UL of Cu is estimated as 0.07 mg/kg bw/day (Pipoyan, et al., 2020). The derived MOEs are presented in Table 2.

Table 2. MOE for copper intake via fish*

HBGV	Clusters	MOE	
		Men	Women
UL	1	877.35	702.35
	2	222.82	178.37
	3	89.98	72.04

Note: HBGV – Health-Based Guidance Value, MOE – Margin of Exposure, UL – Upper Intake Level.

*Composed by the authors.

To assess the risk of As intake via fish consumption we employed the Benchmark Dose Level (BMDL). This point is identical for both men and women – 3 µg/kg bw. The accepted BMDL₀₅ (the lowest dose which with a 95 % probability will produce a ≤ 5 % frequency of the effect) is associated with a 5 % carcinogenic risk (EFSA, 2021). The derived MOEs are presented in Table 3.

Table 3. MOE for arsenic intake via fish consumption*

HBGV	Clusters	MOE	
		Men	Women
BMDL ₀₅	1	157	126
	2	40	32
	3	16.1	12.9

Note: BMDL- benchmark dose (lower confidence limit).

*Composed by the authors.

Risk assessment

MOE≤10 denotes the presence of risk to consumer health. Cu intake via fish poses no threat to men and women in all three consumer clusters since MOE is greater than 10. In the case of As MOE is also > 10 for all the consumer clusters. However, in the case of women included in the 3rd cluster, MOE approximates to 10, which is indicative of a very low possibility to increase a serving size without carcinogenic risk.

The authors believe that there are factors influencing the toxicity level of As in the studied fish which however cannot be quantitatively accounted for. In this research, the sampled fish was analyzed for total As. The specificity of As bioaccumulation by fish is that on average inorganic

As does not exceed 9 % of total *As* (EFSA, 2021). For this cause real toxicity of the studied fish species is at least 11 times lower than the identified concentrations of total *As*. Another influencing factor is connected with the culinary treatment of fish. In Armenia, fish is cooked by various methods including boiling and stewing. However, water in some regions of the country may contain elevated levels of arsenic caused by mining production and the presence of ore deposits (Akopyan, et al., 2018, Tepanosyan, et al., 2021, Babayan, et al., 2019). Cooking foods in *As*-containing water suggests increased concentrations of *As* in cooked food (EFSA, 2009, Camurati and Salomone, 2020). Yet, it is difficult to quantify the effect of cooking the fish in the water of different regions on *As* concentrations.

The worst-case scenario

The highest concentrations of *Cu* and *As* in fish are equal to 0.587 and 0.423 mg/kg, respectively. In the worst-case scenario, these indices are assumed as mean concentrations of elements in fish. The average daily intake corresponds to the value of the 3rd cluster of consumers. The MOE values for the worst-case scenario are provided in Table 4.

Table 4. The worst-case scenario in respect of copper and arsenic concentrations*

PTEs	MOE	
	Men	Women
<i>Cu</i>	57.1	45.71
<i>As</i>	3.40	2.72

*Composed by the authors.

Copper intake via fish produces no harmful effect on consumer health even at the maximum values of variables. In the worst-case scenario for arsenic, the MOE values are <10. Assuming that the total *As* represents inorganic *As*, there can be a possibility of carcinogenic risk to consumers at the maximum levels of variables.

Conclusion

The results of this research indicate that the studied fish samples contain *Cu* and *As*. Three consumer clusters were identified through the analysis of FFQ data. MOE values calculated for both the mean and the highest concentrations (worst-case scenario) of *Cu* indicate that the consumers of all three clusters may safely increase the average daily intake of the studied fish species. *As* intake via fish for the 1st and 2nd clusters poses a risk within allowable limits.

MOE for women included in the 3rd cluster points to the presence of an insignificant health risk. The worst-case scenario also points to the possibility of carcinogenic risk in the case of the increase in the average daily intake of fish containing the maximum concentrations of *As*.

This study is not exempt from several limitations. It should be noted that using the values of inorganic *As* instead of the total would lead to more objective results. Moreover, this study does not account for the role of culinary treatment that may potentially change *As* concentrations in the cooked food. Considering the above stated limitations as well as the need for a precise risk assessment, a more comprehensive approach is required.

References

1. Akopyan, K., Petrosyan, V., Grigoryan, R., Melkomian, D.M. (2018). Assessment of Residential Soil Contamination with Arsenic and Lead in Mining and Smelting Towns of Northern Armenia. *Journal of Geochemical Exploration*, 184, 97-109.
2. Babayan, G., Sakoyan, A., Sahakyan, G. (2019). Drinking Water Quality and Health Risk Analysis in the Mining Impact Zone, Armenia. *Sustainable Water Resources Management*, 5(4), 1877-1886.
3. Berntssen, M.H., Thoresen, L., Albrektsen, S., Grimaldo, E., Grimsmo, L., Whitaker, R.D., ... Wiech, M. (2021). Processing Mixed Mesopelagic Biomass from the North-East Atlantic into Aquafeed Resources; Implication for Food Safety. *Foods*, 10(6), 1265.
4. Burkhead, J.L., Collins, J.F. (2022). Nutrition Information Brief-Copper. *Advances in Nutrition*, 13(2), 681-683.
5. Camurati, J.R., Salomone, V.N. (2020). Arsenic in Edible Macroalgae: an Integrated Approach. *Journal of Toxicology and Environmental Health, Part B*, 23(1), 1-12. <https://doi.org/10.1080/10937404.2019.1672364>.
6. Codex Alimentarius Commission. (2016). Joint FAO/WHO Food Standards Programme (Codex Alimentarius Commission) 39th Session Rome, Italy, 27 June–1 July 2016 and report of the 10th Session of the Codex Committee on Contaminants in Foods, Rotterdam, the Netherlands, 4–8 April 2016.
7. EFSA (European Food Safety Authority), Arcella D, Cascio C and Gomez Ruiz J.A., 2021. Scientific Report on the Chronic Dietary Exposure to Inorganic Arsenic. *EFSA Journal* 2021;19(1):6380, - 50 pp.

8. EFSA Panel on Contaminants in the Food Chain (CONTAM); Scientific Opinion on Arsenic in Food. *EFSA Journal* 2009; 7(10):1351, - [199 pp.].
9. EFSA Panel on Dietetic Products, Nutrition and Allergies (NDA). Scientific Opinion on Dietary Reference Values for Copper //EFSA Journal. – 2015. – vol. 13. – №. 10. – p. 4253.
10. GOST 30178-96. “Raw Materials and Food-Staffs. Atomic Absorption Method for Determination of Toxic Elements”.
11. GOST R 51766-2001. “Raw Materials and Food-Staffs. Atomic Absorption Method for Determination of Arsenic”.
12. Gupta, A.R., Bandyopadhyay, S., Sultana, F., Swarup, D. (2021). Heavy Metal Poisoning and its Impact on Livestock Health and Production System. *Indian J Anim Health*, 60(2), 01-23.
13. Gupta, D.K., Tiwari, S., Razafindrabe, B.H.N., Chatterjee, S. (2017). Arsenic Contamination from Historical Aspects to the Present. In *Arsenic Contamination in the Environment* (pp. 1-12). Springer, Cham, - pp. 1-12. https://doi.org/10.1007/978-3-319-54356-7_1.
14. <https://webgate.ec.europa.eu/rasff-window/screen/notification/512574> (accessed on 18.10.2022).
15. IARC Working Group on the Evaluation of Carcinogenic Risks to Humans, World Health Organization, & International Agency for Research on Cancer. (2004). *Some Drinking-Water Disinfectants and Contaminants, Including Arsenic* (Vol. 84). IARC.
16. Jain, N., Chandramani, S. (2018). Arsenic Poisoning-An overview. *Indian Journal of Medical Specialities*, 9(3), 143-145. <https://doi.org/10.1016/j.injms.2018.04.006>.
17. Kim, J.J., Kim, Y.S., & Kumar, V. (2019). Heavy Metal Toxicity: An Update of Chelating Therapeutic Strategies. *Journal of Trace Elements in Medicine and Biology*, 54, 226-231.
18. Malhotra, N., Ger, T.R., Uapipatanakul, B., Huang, J.C., Chen, K.H.C., Hsiao, C.D. (2020). Review of Copper and Copper Nanoparticle Toxicity in Fish. *Nanomaterials*, 10(6), 1126.
19. Nepovimova, E., Kuca, K. (2019). The History of Poisoning: from Ancient Times until Modern ERA. *Archives of Toxicology*, 93(1), - pp.11-24.
20. Pei, J., Zuo, J., Wang, X., Yin, J., Liu, L., Fan, W. (2019). The Bioaccumulation and Tissue Distribution of Arsenic Species in Tilapia. *International Journal of Environmental Research and Public Health*, 16(5), 757.
21. Pipoyan, D., Hovhannisyan, A., Beglaryan, M., Stepanyan, S., Mantovani, A. (2020). Risk Assessment of Dietary Exposure to Potentially Toxic Trace Elements in Emerging Countries: A Pilot Study on Intake via Flour-Based Products in Yerevan, Armenia. *Food and Chemical Toxicology*, 146, 111768.
22. Pipoyan, D., Stepanyan, S., Beglaryan, M., Stepanyan, S., Mantovani, A. (2020). Health Risk Assessment of Toxicologically Relevant Residues in Emerging Countries: A Pilot Study on Malachite Green Residues in Farmed Freshwater Fish of Armenia. *Food and Chemical Toxicology*, 143, 111526.
23. Rehman, K., Fatima, F., Waheed, I., Akash, M.S. H. (2018). Prevalence of Exposure of Heavy Metals and their Impact on Health Consequences. *Journal of Cellular Biochemistry*, 119(1), - pp. 157-184.
24. Technical Regulation of the Customs Union TR CU 021/2011 “On Food Safety” Dated December 9, 2011 N 880.
25. Tepanosyan, G., Harutyunyan, N., Maghakyan, N., Sahakyan, L. (2021). Toxic Elements Contents and Associated Potential Ecological Risk in the Bottom Sediments of Hrazdan River Under the Impact of Yerevan City (Armenia).
26. WHO (2018). Arsenic: <https://www.who.int/news-room/fact-sheets/detail/arsenic> (accessed on 28.10.2022).
27. WHO (2022). Global Strategy for Food Safety 2022–2030: Towards Stronger Food Safety Systems and Global Cooperation. Available online at: <https://www.who.int/publications/i/item/9789240057685> (accessed on 27.10.2022).
28. Zhong, Q., Cui, Y., Wu, H., Niu, Q., Lu, X., Wang, L., Huang, F. (2019). Association of Maternal Arsenic Exposure with Birth Size: a Systematic Review and Meta-Analysis. *Environmental Toxicology and Pharmacology*, 69, - pp. 129-136. <https://doi.org/10.1016/j.etap.2019.04.007>.

Accepted on 09.11.2022

Reviewed on 29.11.2022

ՊԱՐԲԵՐԱԿԱՆԸ ՆԵՐԱՐՎԱԾ Է ԴՈԿՏՈՐԱԿԱՆ ԵՎ ԹԵԿՆԱԾՈՒԿԱՆ ԱՏԵՆԱԽՈՍՈՒԹՅՈՒՆՆԵՐԻ ԱՐԴՅՈՒՆՔՆԵՐԻ ԵՎ ԴՈՒՅԹՆԵՐԻ ԳՐԱՊՐԱԿԱՆ ԳԱՍԱՐ ԳՅ ԿԳՄՆ ԲՈԿ-Ի ԿՈՂՄԻՑ ԸՆԴՈՒՆԵԼԻ ԳԻՏԱԿԱՆ ՀԱՆԴԵՍՆԵՐԻ ՑԱՆԿՈՒՄ:

ИЗДАНИЕ ВКЛЮЧЕНО В ПЕРЕЧЕНЬ ВЕДУЩИХ НАУЧНЫХ ЖУРНАЛОВ ВАК МНОКС РА, В КОТОРЫХ ДОЛЖНЫ БЫТЬ ОПУБЛИКОВАНЫ ОСНОВНЫЕ РЕЗУЛЬТАТЫ И ПОЛОЖЕНИЯ ДИССЕРТАЦИЙ НА СОИСКАНИЕ УЧЕНОЙ СТЕПЕНИ ДОКТОРА И КАНДИДАТА НАУК.

THE JOURNAL IS INVOLVED IN THE LIST OF SCIENTIFIC PERIODICALS RELEVANT FOR PUBLICATIONS OF THE RESULTS AND PROVISIONS OF DOCTORAL AND PHD THESES AND APPROVED BY THE HIGHER EDUCATION QUALIFICATION COMMITTEE OF THE RA MoESCS.

ՀՈՂՎԱԾՆԵՐԻ ԸՆԴՈՒՄՍԱՆ ԿԱՐԳԸ

1. Հոդվածներն ընդունվում են հայերեն, ռուսերեն և անգլերեն լեզուներով:
2. Հոդվածի առավելագույն ծավալը չպետք է գերազանցի 10 համակարգչային էջը (ներառյալ ամփոփագրերը):
3. Հեղինակների թիվը չպետք է գերազանցի չորսը:
4. Հեղինակների տվյալներում պետք է ներառվեն հեղինակ(ներ)ի անունը, ազգանունը, հայրանունը, գիտական աստիճանը, աշխատավայրը, էլ. հասցեն:
5. Հոդվածը ներկայացվում է տպագիր և էլեկտրոնային (WORD ձևաչափով) տարբերակներով:
6. **Հոդվածը շարադրվում է հետևյալ կառուցվածքով.** վերնագիր, 5 բանալի բառ, «Նախաբան», «Նյութը և մեթոդները», «Արդյունքները և վերլուծությունը», «Եզրակացություն», «Գրականություն»:
7. Գրականության հղումները կատարվում են տեքստում՝ փակագծում նշվում են հեղինակը և հրատարակման տարեթիվը:
8. Հոդվածները պետք է ունենան ամփոփագրեր. հայերենով և ռուսերենով ներկայացված հոդվածների դեպքում՝ հայերեն, ռուսերեն և անգլերեն, անգլերենի դեպքում՝ անգլերեն լեզվով:
9. Յուրաքանչյուր լեզվով ներկայացված ամփոփագրի ծավալը չպետք է գերազանցի 600 նիշը (առանց բացատների):
10. Հայերեն և ռուսերեն հոդվածների վերնագրերը, հեղինակ(ներ)ի տվյալները և բանալի բառերը ներկայացվում են հայերեն, ռուսերեն և անգլերեն լեզուներով:
11. Գրականության ցանկը ներկայացվում է այբբենական կարգով:
12. Էլեկտրոնային հղումը որպես աղբյուր մեջբերելիս գրականության ցանկում նշվում է դիտման ամսաթիվը:

Հոդվածներին ներկայացվող տեխնիկական պահանջներն են. անգլերեն և ռուսերեն հոդվածների տառատեսակը՝ Times New Roman, հայերեն հոդվածներինը՝ GHEA Grapalat, տառաչափը՝ 12, միջտողային տարածությունը՝ 1.5, վերնագիրը՝ մեծատառերով, գծապատկերները՝ Word, Excel ծրագրերով, աղյուսակները՝ ուղղահայաց դիրքով (Portrait), բանաձևերը՝ Microsoft Equation 3.0 ձևաչափով:

Կարգին չհամապատասխանող հոդվածները չեն ընդունվում: Հոդվածներն ուղարկվում են գրախոսման: Մերժված հոդվածները չեն վերադարձվում հեղինակին: Հոդվածները չեն հրատարակվի, եթե ամբողջությամբ կամ համառոտ սուպագրված լինեն այլ պարբերականում:

ПОРЯДОК ПРИЁМА СТАТЕЙ

1. Статьи принимаются на армянском, русском и английском языках.
2. Объем статьи не должен превышать 10 компьютерных страниц (включая аннотации).
3. Число авторов не должно превышать четырёх.
4. В сведениях об авторах должны быть включены имя (имена), фамилия, отчество, научная степень, место работы, эл.адрес.
5. Статья представляется в печатном и электронном (в формате WORD) вариантах.
6. **Статья должна быть изложена следующим образом:** заглавие, 5 ключевых слов, «Введение», «Материал и методы», «Результаты и анализ», «Заключение», «Литература».
7. Ссылки на литературу производятся в тексте с указанием в скобках автора и год издания.
8. Статьи, написанные на русском и армянском языках, должны содержать аннотацию на армянском, русском и английском языках, в статье на английском аннотация пишется на английском языке.
9. Объем представленных аннотаций на каждом языке не должен превышать 600 знаков (без пробелов).
10. Заглавия, данные автора (авторов) и ключевые слова статей на армянском и русском языках представляются на армянском, русском и английском языках.
11. Список литературы представляется в алфавитном порядке, сначала на языке статьи, затем на иностранном языке.
12. При ссылке в статье на интернет-ресурс как источник информации, в списке литературы необходимо отметить дату просмотра.

Технические требования к статьям: для статей на английском и русском языках - шрифт Times New Roman, для армянского - GHEA Grapalat; размер букв - 12; межстрочное расстояние - 1.5; заголовки - прописными буквами; графические изображения - программой Word, Excel; таблицы - вертикально (Portrait); формулы - в формате Microsoft Equation 3.0;

Статьи, не отвечающие требованиям, не будут приняты. Статьи передаются на рецензирование. Статьи, не принятые к печати, не возвращаются автору. Статьи не будут опубликованы, если ранее были полностью или частично опубликованы в других периодических изданиях.

THE STANDARDS FOR SUBMITTING ARTICLES

1. The articles are accepted in Armenian, Russian and English languages.
2. The size of the article shouldn't exceed 10 PC pages (including summaries).
3. The number of authors should not exceed four.
4. Full name, academic degree, workplace and e-mail of the author (s) should be included in the information about the authors.
5. The article is submitted in a hard copy and electronically (WORD format).
6. **The article should have the following structure:** title, 5 keywords, "Introduction", "Materials and Methods", "Results and Discussions", "Conclusion", "References".
7. References to the literature should be indicated in the text (the author and the date of publication in the parentheses).
8. Articles should have abstracts; for Armenian and Russian articles they should be in Armenian, Russian and English languages, for English articles only abstracts in English language are required.
9. The volume of the abstracts presented in each language should not exceed 600 characters (no spaces).
10. The titles, information about the author(s) and keywords should be presented in Armenian, Russian and English languages.
11. The list of references should be arranged in alphabetical order.
12. When citing internet links as a literature source the date of access should be mentioned.

Technical requirements for articles: font for English and Russian articles: Times New Roman, for Armenian articles: GHEA Grapalat, font size: 12, interstitial spacing: 1.5, title: with capital letters, charts: with Word, Excel, tables: vertical (Portrait), formulas: in Microsoft Equation 3.0 format.

Articles that do not meet the requirements are not accepted. Articles are sent for review. Refused articles are not returned to the authors. The articles which are already published in other scientific journals (completely or partially) can't be valid for publication in our journal.

☎ (+374 12) 56-07-12, (+374 12) 58-79-82

✉ agriscience@anau.am

URL: <https://anau.am/scientific-journal>

Հասցե՝ Երևան 0009, Տերյան 74, IV հարկ, 421 սենյակ

Адрес: Ереван 0009, Терян 74, IV этаж, 421 кабинет

Address: 74 Teryan, Yerevan 0009, IV floor, room 421